

CATALOGUE 2008
V.02

**ventilation
and air conditioning systems
for circular and rectangular airway channels**



TABLE OF CONTENTS

Air Handling Units MWR	2
Filter sections	4
Heating section	4
Cooling sections	5
Sections of the Plate Heat Exchanger	6
Sections of the Rotor Heat Exchanger	7
FAN sections	7
Section of the sound attenuator	8
Connection elements	8
Damper	9
Mixing section	9
Separating sections for the reserve FAN	10
Empty section	10
Upper air intake unit (exhaust upwards)	10
The combined units	11
Automatic system of the air handling unit	11
Selecting the AHU	11
Table of overall dimensions of the basic functional units of the air handling unit	12
Table of the connecting dimensions	15

AIR HANDLING UNITS MWR

General information

The Air Handling Units MWR are used in the ventilation and air-conditioning systems and those are designed to maintain the required climate indoors. The units may include different functional sections (filtering, heating, cooling, noise reducer, etc.).

The high-performance energy-saving technologies are widely used in the units. In particular, the plate heat exchanger (the heat utilization efficiency coefficient is up to 70%) as well as the rotor heat exchangers (the heat utilization efficiency coefficient is up to 85%) are installed.

The AHU are equipped with the high-quality FAN assemblies with «free» impellers with high aerodynamic properties and minimal power consumption. The units are connected directly to the air ducts of the central ventilation system of a building.

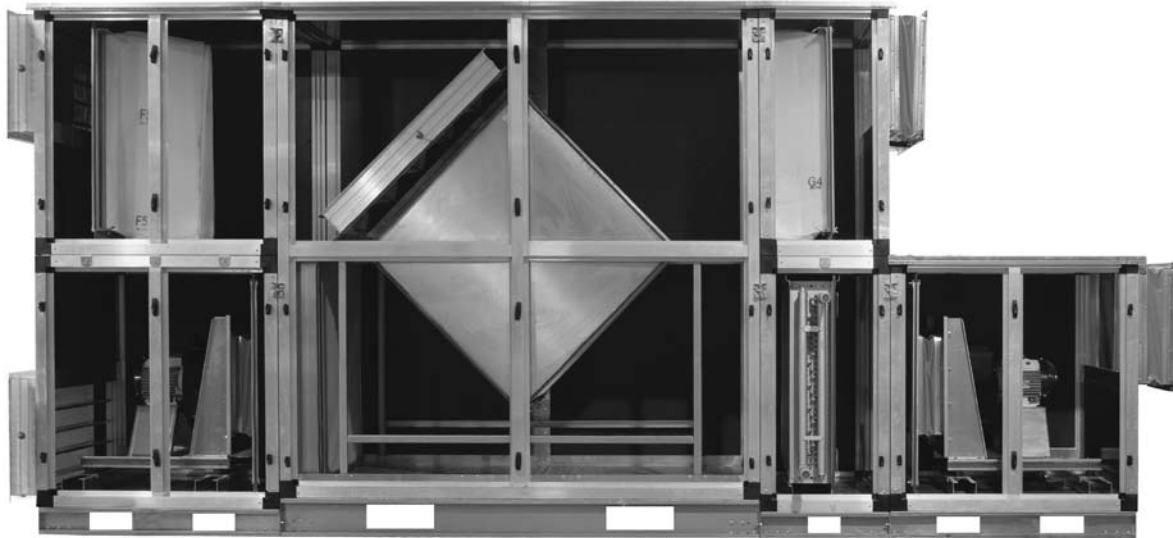

Standard sizes

The air handling units are manufactured of 6 standard sizes, and those ensure the air flow from 3500 up to 55000 m³/h. The air flow data of the units are shown in the table below.

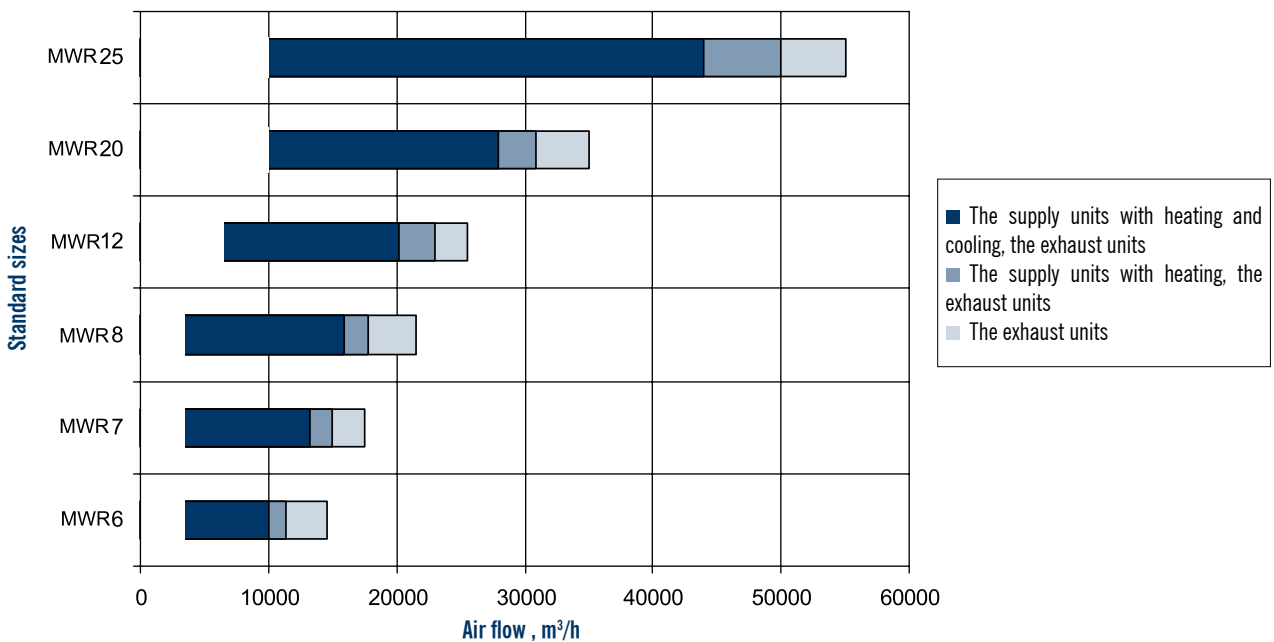

Designation of the Air Handling Units

The marking example of a one-deck AHU is shown in the scheme below:

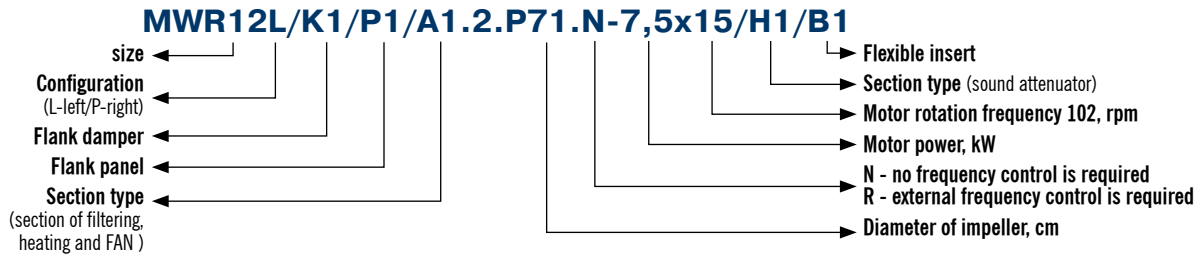

The designations of each section are shown in the corresponding chapters of the present catalogue.

The double-deck units are designated according to the following rules:

1. Consecutively the supply part is specified in the direction of the airflow, then after the delimiter (the «+» sign) the exhaust part of the unit is specified in the code of unit.
2. If the section (or the terminal element) is installed on the second deck, then the digit 2 must stand in the beginning before its designation.
3. The integrated double-deck sections are included into the code of both supply and exhaust parts.

The designation sample of the supply-exhaust unit with the plate-heat exchanger is shown below.

MWR6L/2K1/2P1/2F5/R1/N1.2/V1.0.P50.R-4x15/P+P/2P1/2F1/R1/V1.0.P50.R-3x15/P1/K1

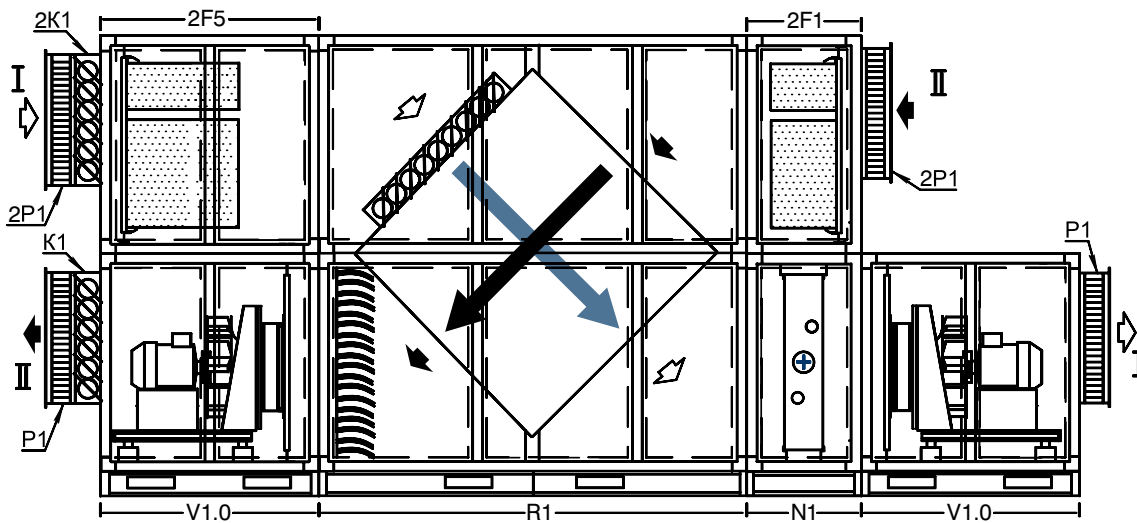
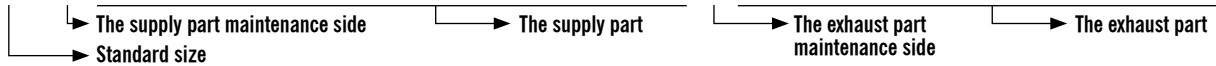

Formation of the unit code takes place automatically during the programmed calculation.

Design of the housing

The AHU represent a set of the functional units connected in series. The configuration of units can be both one-deck (all sections are located in one deck) and double-deck. The casing of each section of the first deck is attached to its own bearing frame. Sections of the second deck have no frames. Those are attached to the units of the first deck by means of special brackets.

The framework of the sections is made of aluminum shaped bars interconnected with the high-strength plastic angle pieces. The framework is encased with the sandwich-panels 45mm thick. The panels consist of two zinc-coated steel sheets with the polyurethane foam filling between those.

The removable maintenance panels with handles are installed in the unit sections for the maintenance purposes. The removable panels have an additional sealing from the inside to ensure firm adherence.

FILTER SECTIONS MWR

The filter sections are designed to reduce the content of dust and other harmful particles in the air supplied by the AHU to the serviced premises. Besides, the application of the filter sections makes it possible to protect the air processing equipment from pollution, which deteriorates its heat engineering properties and increases its aerodynamic resistance. The filter sections are manufactured up to three filtration stages according to the EN779 with filtering inserts G4, F5, F7. The filter sections with inserts of the filtration class G4, as a rule, are applied for the primary stage of air filtration from large dust particles. The filter sections with inserts of the filtration class F5 can be applied as both primary and only stage of the air filtration or as a filter of the secondary filtration stage. The filter sections with inserts of the filtration class F7, as a rule, are applied as the final filtering stage. Those are recommended to be installed at the end of the AHU.

The filter sections consist of the directional and filtering inserts, which makes it possible to easily replace the filter from the removable panel side. To control the filter clogging the sections can be equipped with the pressure drop sensor.



Designation:

F1 - filtering section of class G4

F5 - filtering section of class F5

F7 - filtering section of class F7

Scheme of the section:



HEATING SECTION MWR

The air heater section is designed to heat up the air supplied by the AHU to the serviced premises. Water or nonfreezing mixture is used as the heat agent in the heating section.

The air heater section consists of the heat exchanger installed in the section casing on the slides, which makes it possible to remove it from the section during maintenance.

The temperature of the heat agent should not exceed 170°C, while the pressure should not exceed 1.5MPa.

The high-performance copper-aluminum plate-type two and three-row heat exchangers, the surface of which is formed by the bundle of copper pipes ribbed with the press-fitted aluminum foil plates, are used as the heater in the AHU. The connection of the supply and exhaust pipe branches to the heat supply network is carried out by means of the threaded connections.

Diameters of the supply and outlet pipe branches depending on the sizes are listed in the table below.

Table of the connecting thread of the water air-heaters

Standard size of installation	Thread type	
	two-row heaters	three-row heaters
MWR6	G1 1/4	G1 1/2
MWR7	G1 1/2	G1 1/2
MWR8	G1 1/2	G2
MWR12	G2	G2
MWR20	G2	G2 1/2
MWR25	G2 1/2	G3

To protect the heat agent from freezing the heating section can be equipped with the capillary thermostat as well as the return water temperature sensor.

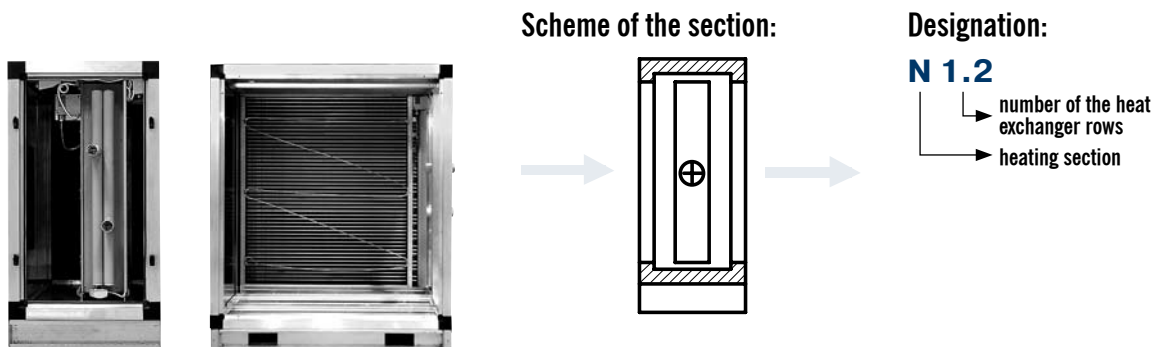

COOLING SECTIONS MWR

The air cooler section is designed to cool down the air supplied by the AHU to the serviced premises.

The cooling section consists of the air cooler, drop eliminator and the tray, which are connected to each other and installed in the section casing on the slides, which makes it possible to remove those from the section during maintenance.

The tray is designed to collect the condensed water, and it is located under the cooler and the drop eliminator. To drain the condensate, there is a drainage pipe designed in the tray going outside the front panel of the section casing with the thread G1 1/2 at the end.

The drop eliminator represents a set of vertical shaped bars in the form of a single module, which collects the condensate. The high-performance copper-aluminum three and four-row heat exchangers, the surface of which is formed by the bundle of copper pipes ribbed with the press-fitted aluminum foil plates, are used as the air cooler.

Depending on the applied coolant, the air cooler can be running on water or freon.

The freon coolers are performed with two circuits.

The connection of the supply and exhaust pipe branches of the cooler to the network is carried out:

- for the water ones by threaded connection;
- for the freon ones by soldering.

Diameters of the supply and outlet pipe branches of the coolers depending on the standard sizes are listed in the table below.

Table of the connecting thread of the water air-coolers

Standard size of installation	Thread type	
	two-row heaters	three-row heaters
MWR6	G1 1/2	G1 1/2
MWR7	G1 1/2	G1 1/2
MWR8	G1 1/2	G2
MWR12	G2	G2
MWR20	G2	G2 1/2
MWR25	G2 1/2	G3

Table of the connecting diameters of the fluid and gas lines of the freon air-coolers

Standard size of installation	diameter of the fluid line, mm	diameter of the gas line, mm
MWR6	22	28 for 3-row, 35 for 4-row
MWR7	22	35
MWR8	22	35
MWR12	22	35
MWR20	28	42
MWR25	28	42

The heat agent supply for air-coolers should be carried out by the counter-flow scheme.
The freon coolers can be equipped with the capillary thermostats for each circuit to avoid frosting of evaporator.

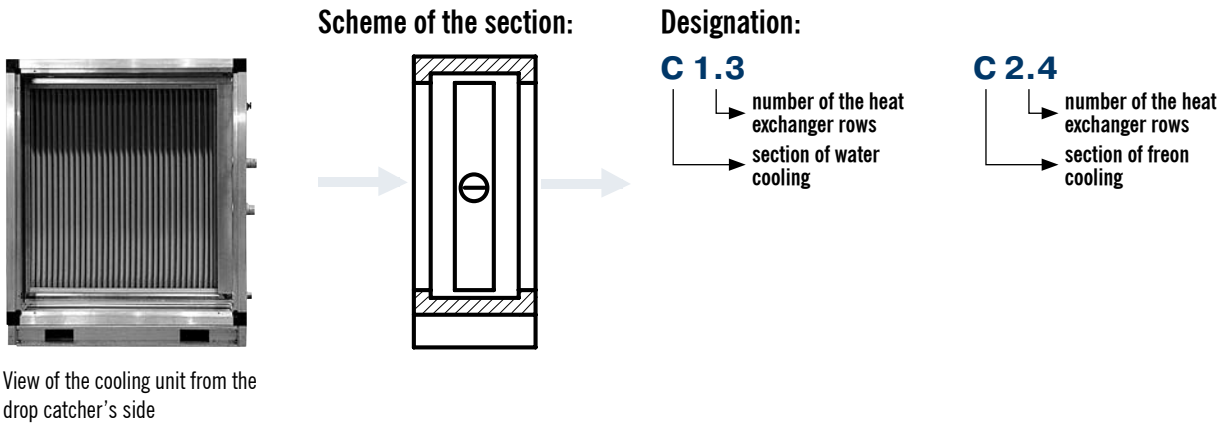

SECTIONS OF THE PLATE HEAT EXCHANGERS MWR

The plate-type heat exchangers are designed for efficient utilization (up to 70%) of the of the exhaust air heat. The heat exchange surface of the recuperator is formed by the stack of special aluminum plates. The air motion is cross-flow.

The recuperator unit is equipped with the intake air bypass for protection of the heat exchanger from frosting at the exhaust as well as to prevent the undesirable recuperation (as a rule in the summer). The bypass is equipped with the air damper, which is inversely connected with the damper in the main cross-section of recuperator.

There is a drop eliminator installed in the exhaust branch of the recuperator to collect the water drops appearing during condensation. The recuperator section is equipped with the pallet baths with the drainage pipe branches to collect and drain the condensate.

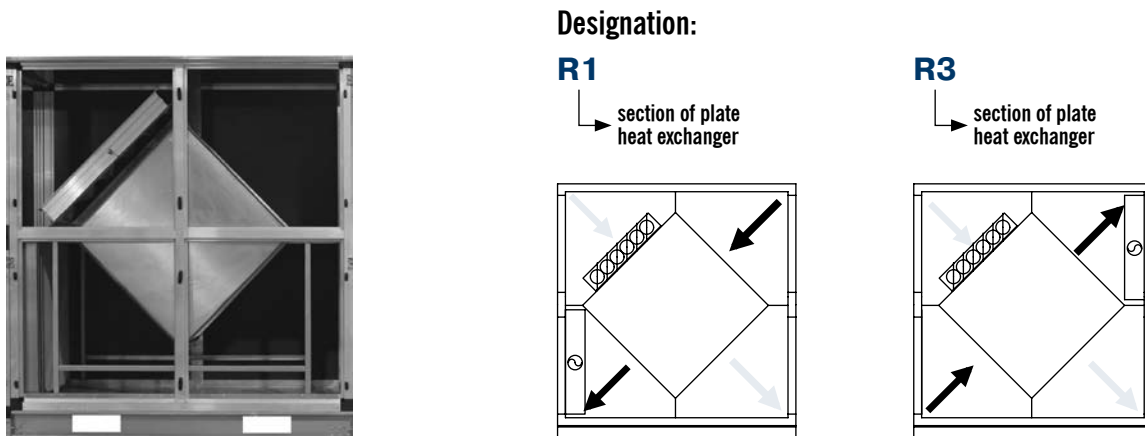
Depending on the direction of the intake and exhaust air flows the two types of the heat exchanger section R1 (the opposite direction of the flows) and R3 (the parallel direction of the flows) are manufactured.



In the units MWR of standard sizes 12, 20 and 25 the plate heat exchangers sections R1, R3 are delivered in disassembled state. The price of such units does not include the cost for assembly and contract supervision.

SECTION OF THE ROTOR HEAT EXCHANGER MWR

The rotor heat exchanger are designed for the high-performance utilization (up to 85%) of the exhaust air heat. The heat exchange surface of the heat exchanger is formed by rotating drum made out of the wavelike aluminum bands. In the area of the hot exhaust air, the aluminum bands accumulate the thermal energy, which, when the drum is turned to the supply area, is transferred to the cold air. The maximum efficiency coefficient is achieved at the oncoming flow direction of the supply and exhaust air.

In the rotor regenerators, some cross-flow between the airflows is possible. In order to minimize it there is the brush-type sealing on the rotor rim.

The rotor is driven by the three-phase asynchronous motor through the belt drive. The motor itself is connected to the external frequency inverter type rpm controller. It makes it possible to obtain the optimal speed of the rotor (to achieve the maximum efficiency coefficient) as well as to switch the regenerating heat exchanger into the defrosting mode when there is the threat of frosting, by dropping the rotor speed to the minimal values.

For collection and drainage of the possible condensate, the heat exchanger section is equipped with a condensate tray with the drainage pipe branch.

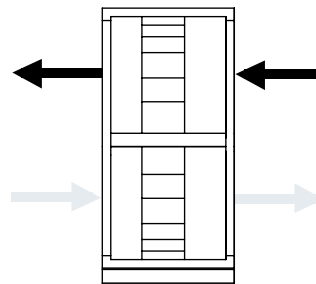

Designation:

R2

section of rotor heat exchanger

In the units MWR of standard sizes 12, 20 and 25 the rotor heat exchanger sections R2 are delivered in disassembled state. The price of such units does not include the cost for assembly and contract supervision.

FAN SECTIONS MWR

The FAN section is designed for movement of air in the AHU and supplying it to the serviced premises.

The FAN section consists of the FAN set mounted on the vibration isolators, intake wall with guides and flexible insert preventing from transfer of vibration to the section of the central AHU.

The FAN set represents a frame with the impeller located directly on the motor shaft. If it necessary to control the rotation speed of impeller the external frequency control is used.

In the units MWR the impellers with the backward-curved blades are used.

In the FAN set of the AHU the asynchronous three-phase motors are used. When there is no frequency controller, in order to minimize the impact of the starting current, the ventilators of the capacity of 4 kW and higher should be operated along with the external two-step starting device (switching of the motor feeding from the star to the delta connection).

To control the serviceability, the unit can be equipped with the pressure drop sensor. The FAN section is equipped with the removable panel from the maintenance area side.

If the AHU ends with the FAN section, then it is recommended to install the flank panel with flexible insert at the outlet of this section. It is possible to use the flank panel with the damper, however it is inadmissible to install the flank panel with the damper at the intake of the FAN set.

Types of the FAN section



V1.0 – ventilation with horizontal air exhaust

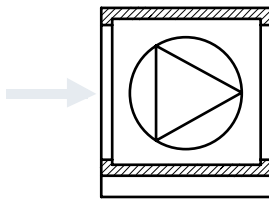

Designation:

V1.0.P63.N-5,5x15

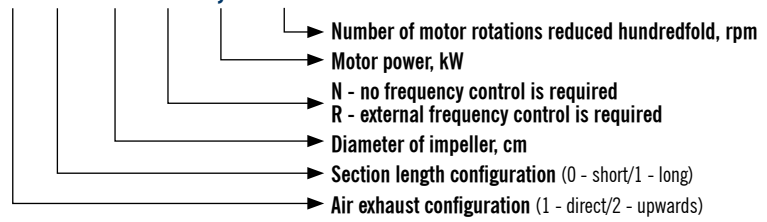

V2.0 – ventilation with upward air exhaust

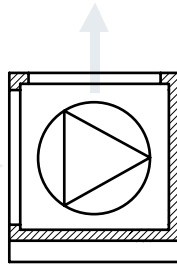

SECTION OF THE SOUND ATTENUATOR MWR

The sound attenuator section decreases the noise level from the functional units of the AHU. FANS is the major source of noise in the AHU.

The noise reducer section consists of a set of cartridges, which represent a box with the sound-absorbing material plates installed inside. The sound-absorbing material is the basalt-fiber mineral wool with the high acoustic properties.

Scheme of the section:

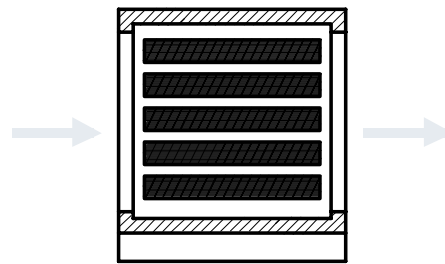

Designation:

H1

→ section of the sound attenuator

COMMUTATION ELEMENTS

For connection of the AHU to the air duct system the AHU is equipped with the terminal elements: flexible inserts for whole area B1, flank panels with flexible inserts P1, P2 or flank panels without the flexible inserts P5. it is possible to install the external dampers K1 or K2 on the panels P1, P2, P5.

DAMPER

The damper is designed for intake, shutting and adjustment of the air flow incoming or outgoing from the AHU. The damper represents a casing with the flaps installed in it. The flaps are gear wheel driven. The damper flaps can be controlled both electrically and manually. The damper is installed outside the housing of the AHU on the flank panels.



Scheme of the section:

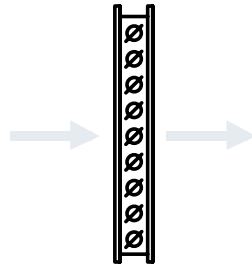

Designation:

K 1
 1 - vertical
 2 - horizontal
 damper

MIXING SECTION MWR

The intake-mixing sections are designed for intake, mixing and adjustment of the amount of air entering the air-conditioner.

The air intake is can be taken both from the top and the front of the section in the direction of the airflow. The mixing unit should be equipped with the flank and upper flank panels with gates and soft inserts. The damper are located inside the mixing unit. The damper flaps are controlled both electrically and manually.



Scheme of the section:

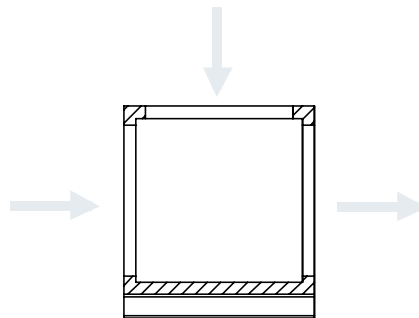

Designation:

S1
 mixing section

The mixing sections S2 are manufactured for the double-deck installations.

The mixing damper is included into these units. Such sections should be additionally equipped with the flank panels with gates and soft inserts (at the intake and exhaust). The dampers are located inside the mixing unit.

Scheme of the section:

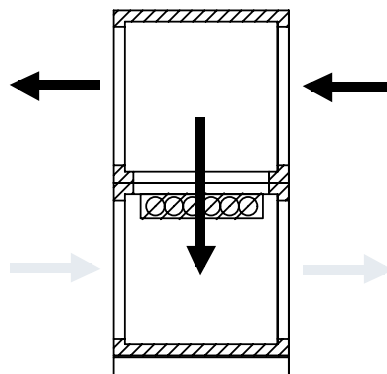

Designation:

S2
 mixing section

SEPARATING SECTIONS FOR THE RESERVE FAN

These sections are applied for separation and shutting of ducts of both main and reserve FAN.

The section S3 is designed for installation at the intake of FAN. The section S4 is designed for installation at the outlet of ventilators. There are two internal dampers in the section S4, which shut off the ducts of both main and standby ventilators.

Scheme of the section:

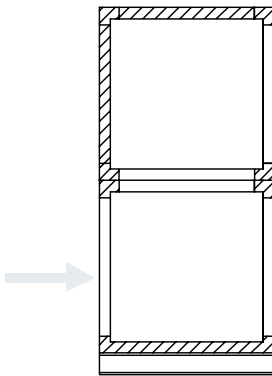

Designation:

S3
separating section

Scheme of the section:

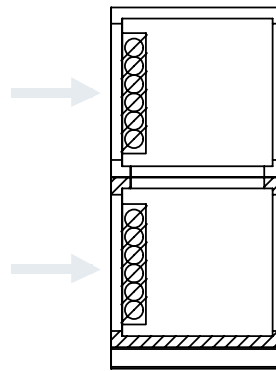

Designation:

S4
separating section

EMPTY SECTION MWR

This section represents an empty section. It can be used to equalize the air flow between the functional elements of the air-conditioner. For example, when it is required to place the damper at the intake of the ventilation section or before the sound attenuator section.

Scheme of the section:

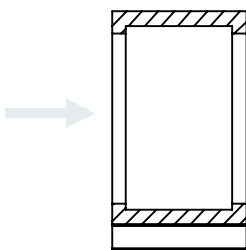

Designation:

Z1
empty section

UPPER AIR INTAKE UNIT (EXHAUST UPWARDS) MWR

This unit represents an empty section. The unit is designed to ensure the vertical air intake or vertical air supply from the AHU. This section should be equipped with the upper flank panel with soft insert with the damper (or without the damper). The dampers are installed on the panel outside the intake unit.

Scheme of the section:

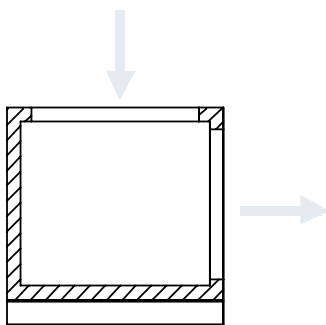













Designation:

Z2
Upper air intake section (exhaust upwards)

TABLE OF OVERALL DIMENSIONS OF THE BASIC FUNCTIONAL SECTIONS OF THE AIR HANDLING UNITS

In the tables: B - width, H - height, L – length of the sections

			MWR6	MWR7	MWR8	MWR12	MWR20	MWR25	
SINGLE SECTIONS									
F1,2F1	Filtering G4		B	1100	1100	1320	1435	1660	2045
			H	1100	1320	1320	1435	1660	2045
			L	575	575	575	575	575	575
F5,2F5 F7,2F7	Filtering F5 Filtering F7		B	1100	1100	1320	1435	1660	2045
			H	1100	1320	1320	1435	1660	2045
			L	1100	1100	1100	1100	1100	1100
N1,2N1	Heating (water)		B	1100	1100	1320	1435	1660	2045
			H	1100	1320	1320	1435	1660	2045
			L	575	575	575	575	575	575
C1,2C1 C2,2C2	Cooling (water) Cooling (freon)		B	1100	1100	1320	1435	1660	2045
			H	1100	1320	1320	1435	1660	2045
			L	575	575	575	575	575	575
V1.0, 2V1.0	FAN (direct exhaust)		B	1100	1100	1320	1435	1660	2045
			H	1100	1320	1320	1435	1660	2045
			L	1100	1100	1100	1100	1100	1100
V1.1, 2V1.1	FAN (direct exhaust)		B	1100	1100	1320	1435	1660	2045
			H	1100	1320	1320	1435	1660	2045
			L	1625	1625	1625	1625	1625	1625
V2.0, 2V2.0	FAN (exhaust upwards)		B	1100	1100	1320	1435	1660	2045
			H	1100	1320	1320	1435	1660	2045
			L	1100	1100	1100	1100	1100	1100
V2.1, 2V2.1	FAN (exhaust upwards)		B	1100	1100	1320	1435	1660	2045
			H	1100	1320	1320	1435	1660	2045
			L	1625	1625	1625	1625	1625	1625
H1,2H1	Sound attenuator		B	1100	1100	1320	1435	1660	2045
			H	1100	1320	1320	1435	1660	2045
			L	1100	1100	1100	1100	1100	1100
H2,2H2	Sound attenuator		B	1100	1100	1320	1435	1660	2045
			H	1100	1320	1320	1435	1660	2045
			L	1625	1625	1625	1625	1625	1625
S1,2S1	Mixing		B	1100	1100	1320	1435	1660	2045
			H	1100	1320	1320	1435	1660	2045
			L	575	575	575	1100	1100	1100
Z1,2Z1	Empty		B	1100	1100	1320	1435	1660	2045
			H	1100	1320	1320	1435	1660	2045
			L	575	575	575	575	575	575
Z2,2Z2	Upper air intake		B	1100	1100	1320	1435	1660	2045
			H	1100	1320	1320	1435	1660	2045
			L	575	575	575	1100	1100	1100
P0,2P0	Blind flank panel	Installation of the panel does not affect the overall dimensions of the air-							
<p><i>Note: The outer height (size «H») is given without the height of the height of the basis frame of the sections.</i></p> <p><i>The height of the basis frame of the sections R1, R2, R3 is 170mm, for others 120mm. The sections of the second deck are manufactured without basis, however they have a special plate 3mm thick for the inter-deck attachment of the sections. In order to obtain the dimensions of the internal cross-section you should deduct 100mm from the sizes «B» and «H» respectively.</i></p> <p><i>For the soft inserts and flank panels the connecting dimensions are given, for the dampers the dimensions of the open flow area are given.</i></p>									

			MWR6	MWR7	MWR8	MWR12	MWR20	MWR25		
COMBINED SECTIONS										
A1,2A1	Filtering G4 Water heating FAN (direct exhaust)			B	1100	1100	1320	1435	—	—
				H	1100	1320	1320	1435	—	—
				L	2150	2150	2150	2150	—	—
A2,2A2	Filtering G4 Water heating FAN (exhaust upwards)			B	1100	1100	1320	1435	—	—
				H	1100	1320	1320	1435	—	—
				L	2150	2150	2150	2150	—	—
F3,2F3	Mixing Filtering G4			B	1100	1100	1320	1435	1660	2045
				H	1100	1320	1320	1435	1660	2045
				L	1100	1100	1100	1625	1625	1625
F4,2F4	Upper air intake Filtering G4			B	1100	1100	1320	1435	1660	2045
				H	1100	1320	1320	1435	1660	2045
				L	1100	1100	1100	1625	1625	1625
N2,2N2	Filtering G4 Heating (water)			B	1100	1100	1320	1435	1660	2045
				H	1100	1320	1320	1435	1660	2045
				L	1100	1100	1100	1100	1100	1100
N3,2N3	Mixing Filtering G4 Heating (water)			B	1100	1100	1320	1435	1660	2045
				H	1100	1320	1320	1435	1660	2045
				L	1625	1625	1625	2150	2150	2150
N5,2N5	Filtering F5 Heating (water)			B	1100	1100	1320	1435	1660	2045
				H	1100	1320	1320	1435	1660	2045
				L	1625	1625	1625	1625	1625	1625
T1,2T1	Heating (water) Cooling (water)			B	1100	1100	1320	1435	1660	2045
T2,2T2	Heating (water) Cooling (freon)			H	1100	1320	1320	1435	1660	2045
L	1100	1100		1100	1100	1100	1100			
T3,2T3	Filtering G4	Heating (water) Cooling (water)		B	1100	1100	1320	1435	1660	2045
				H	1100	1320	1320	1435	1660	2045
T4,2T4	Filtering G4	Heating (water) Cooling (freon)		L	1625	1625	1625	1625	1625	1625
T5,2T5	Filtering F5	Heating (water) Cooling (water)		B	1100	1100	1320	1435	1660	2045
				H	1100	1320	1320	1435	1660	2045
T6,2T6	Filtering F5	Heating (water) Cooling (freon)		L	2150	2150	2150	2150	2150	2150

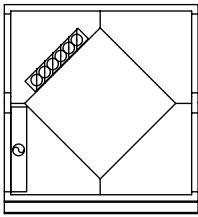
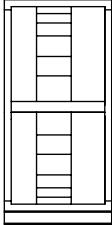
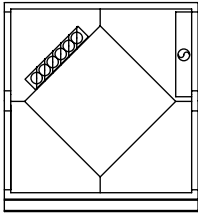
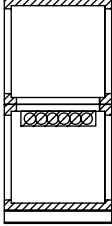
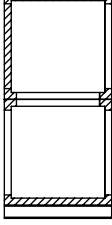
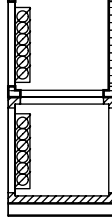
			MWR6	MWR7	MWR8	MWR12	MWR20	MWR25	
The double-deck sections									
R1	Plate Heat Exchanger		B	1100	1100	1320	1435	1660	2570
			H	2153	2593	2593	2823	3273	4043
			L	2150	2675	2375	3200	3730	3730
R2	Rotor Heat Exchanger		B	1615	1825	1975	2255	2610	3005
			H	2153	2593	2593	2823	3273	4043
			L	680	980	840	980	1100	1100
R3	Plate Heat Exchanger		B	1100	1100	1320	1435	1660	2570
			H	2153	2593	2593	2823	3273	4043
			L	2150	2675	2375	3200	3730	3730
S2	Mixing		B	1100	1100	1320	1435	1660	2045
			H	2153	2593	2593	2823	3273	4043
			L	575	575	575	1100	1100	1100
S3	Separating section of the reserve FAN (at the intake)		B	1100	1100	1320	1435	1660	2045
			H	2153	2593	2593	2823	3273	4043
			L	575	575	575	1100	1100	1100
S4	Separating section of the reserve FAN (at the exhaust)		B	1100	1100	1320	1435	1660	2045
			H	2153	2593	2593	2823	3273	4043
			L	575	575	575	1100	1100	1100

			MWR6	MWR7	MWR8	MWR12	MWR20	MWR25	
The double-deck sections									
P1, 2P1	Flank panel		B	1040	1040	1240	1358	1582	1968
			H	540	740	740	840	1040	1440
			L	150	150	150	150	150	150
			B1	1010	1010	1210	1328	1552	1938
			H1	510	710	710	810	1010	1410
P2, 2P2	Upper flank panel		B	1040	1040	1240	1358	1582	1968
			H	540	540	540	1040	1040	1040
			L	150	150	150	150	150	150
			B1	1010	1010	1210	1328	1552	1938
			H1	510	510	510	1010	1010	1010
B1, 2B1	The cross-section flexible insert		B	1022	1022	1242	1357	1582	1968
			H	1022	1242	1242	1357	1582	1968
			L	150	150	150	150	150	150
			B1	992	992	1212	1328	1552	1938
			H1	992	1212	1212	1328	1552	1938
P5, 2P5	Flank panel without the flexible insert		B	1000	1000	1220	1335	1560	1945
			H	495	695	695	810	1035	1420
K1, 2K1	Flank damper		B	1040	1040	1240	1358	1582	1968
			H	540	740	740	840	1040	1440
			L	125	125	125	125	125	125
			B1	1020	1020	1220	1338	1562	1948
			H1	510	710	710	810	1010	1410
K2, 2K2	Upper damper		B	1040	1040	1240	1358	1582	1968
			H	540	540	540	1040	1040	1040
			B1	1020	1020	1220	1338	1562	1948
			H1	510	510	510	1010	1010	1010
			L	125	125	125	125	125	125

			MWR6	MWR7	MWR8	MWR12	MWR20	MWR25
P1, P2, P5	Flank panels	B	1040	1040	1240	1358	1582	1968
		H	540	740	740	840	1040	1440
B1	Flexible insert	B	1022	1022	1242	1357	1582	1968
		H	1022	1242	1242	1357	1582	1968

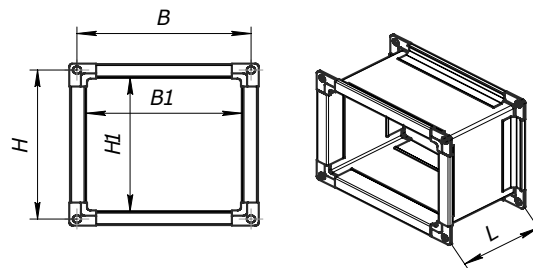

NOTES

Manufacturer can make alterations
without prior notice.

Cesu street 31, building 1, 3d floor, Riga, Latvia, LV-1012
Tel: 7501707, 7501708; Fax: 7501710
e-mail: info@evr.lv
www.evr.lv