

CATALOGUE 2007
V.01

**ventilation
and air conditioning systems
for circular and rectangular airway channels**



CONTENTS

Radial ventilators for round channels LKK	2
Radial ventilators for rectangular channels LVR with forward inclined blades.....	5
Radial ventilators for rectangular channels LVP with backward inclined blades	18
Roof ventilators LVK	28
Water air-heaters for round channels WKK	30
Water air-heaters for rectangular channels WKN	31
Mixing units SRP	34
Electric air-heaters for round channels EKK	37
Electric air-heaters for rectangular channels EKN	39
Freon air-heaters for rectangular channels KFO	42
Water air-coolers for rectangular channels KWO	43
Plate-type recuperators for rectangular channels RPK.....	45
Cassette filters for round channels FKK	47
Cassette filters for round channels KFK	48
Pocket filters for rectangular channels KFR and KFU	50
Adjusting chokes for round channels ZOK	52
Adjusting chokes for rectangular channels ZOR	53
Return valves for round channels OPK	54
Mufflers for round channels KSK.....	55
Mufflers for round channels KSG	56
Flexible connector for rectangular channels WKG.....	57
Clamps HSK	58
Transformer rpm regulators type RE... and RD..	59
Transformer rpm regulators type RET.. and RDT.....	60
Electronic rpm regulator FC 2	61
Frequency rpm regulators type SINUS N and SINUS M	61
Protective relays STDT16, S-ET10	62
Engine start-up and protection device UZ-V...	63
Ventilators control panel PU-V...	63
Control units type PUAT	64
Control units type PUA 210	66
Control units type PUA 222	67
Control units type PUA 236	70
Temperature sensors	74
Capillary thermostats AZT...	76
Differential pressure sensors DPD...	77
Electric drives of air chokes	77
Three-way valves and drives	78
Air curtains type ZWC	82
Air curtains control units PU-ZWC	84

RADIAL VENTILATORS FOR ROUND CHANNELS LKK

General information

Radial ventilators LKK are meant for shifting air and other nonaggressive gas mixtures. Ventilators are mounted directly into the round air channels.

Maximal temperature of the shifting air - 50°C (40° C for LKK 315/1).

Ventilators can be mounted in any position.

Construction and materials

Ventilator casing is made of a durable plastic.

Ventilators are fitted with one-phase asynchronous motors with outer rotor and backward inclined blades.

All the electric motors have an overheating protection provided by built-in heat contacts with auto-restart.



Delivery control

Delivery control of electric motors is implemented by changing the supplied voltage. It is recommended to use electronic tiristor (smooth power variation) or transformer (step capacity variation) regulators.

Dimension-types and basic technical information

Dimension type	Motor revolutions, min	Motor revolutions, min	Maximal power, W	Maximal current, A
LKK 100/1	2450	1~220	56	0,25
LKK 125/1	2450	1~220	76	0,35
LKK 160/1	2550	1~220	106	0,48
LKK 200/1	2600	1~220	163	0,74
LKK 250/1	2500	1~220	195	0,89
LKK 315/1	2500	1~220	313	1,42

Dimensions and weight

Dimension type	A	B	C	Mass, kg
LKK 100/1	215	251	99	1,95
LKK 125/1	220	251	124	2,36
LKK 160/1	230	340	156	3,70
LKK 200/1	250	340	199	4,90
LKK 250/1	250	340	249	5,30
LKK 315/1	285	405	314	5,70

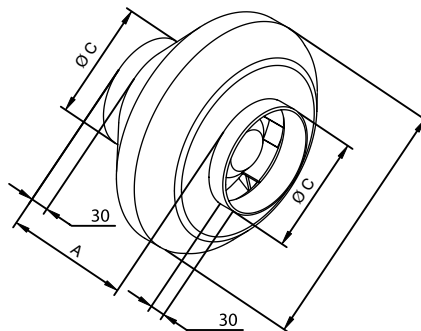
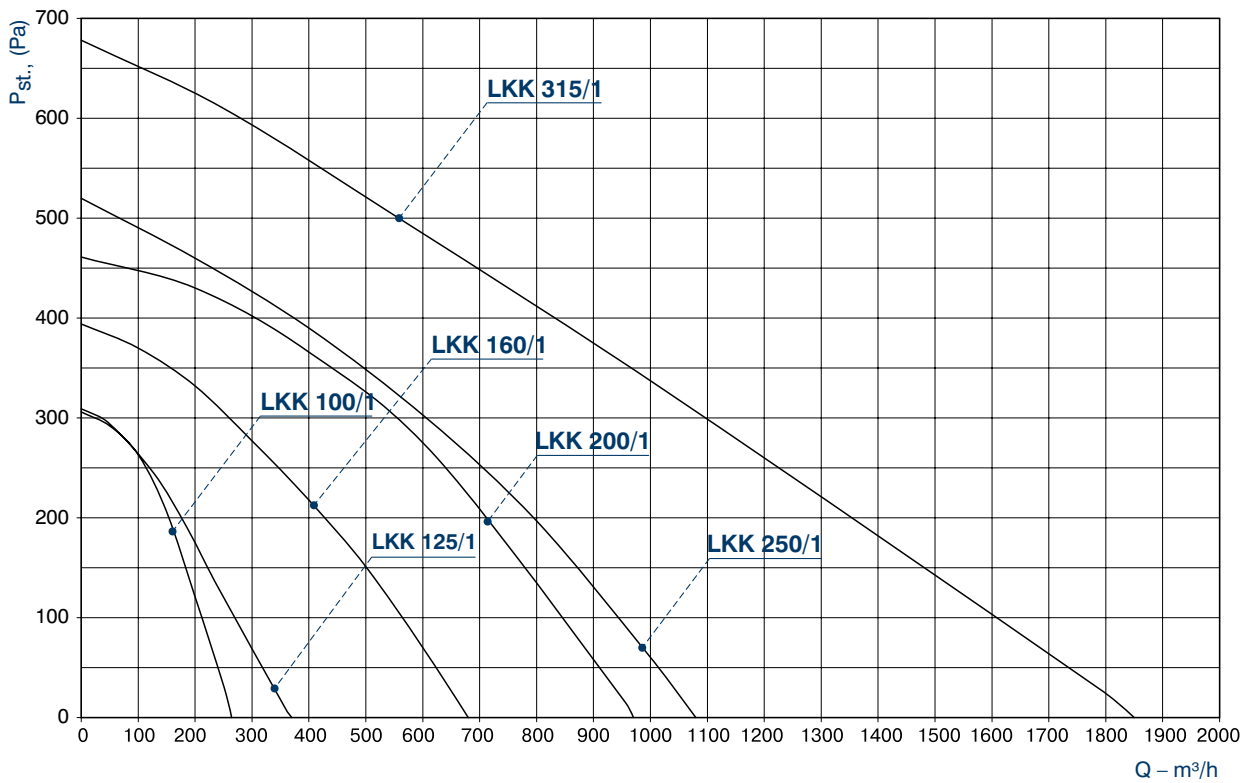
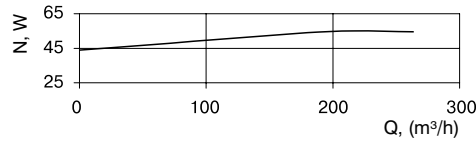
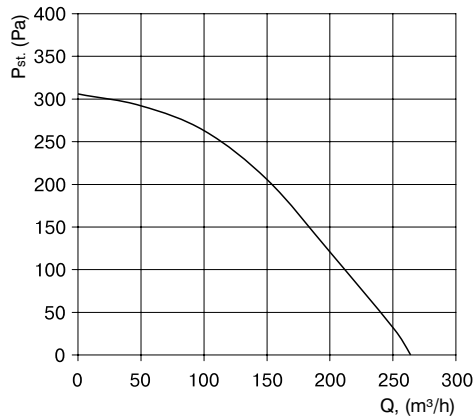

Diagram for quick selection



Technical data

Technical data for ventilators LKK 100/1



LKK 100/1 acoustic characteristics										
Operation mode, Pa	Sound level LPa, dBA	Total level, LPs, dB	Sound pressure level (Lps, dB) in octave-frequency band, Hz							
			63	125	250	500	1000	2000	4000	8000
Suction side noise	200	67,67	76,7	72,2	71,1	65,2	59,4	58,2	51,5	48,1
Noise through casing	200	50,04	69,77	69,7	47,2	42,1	45,2	45,4	41,2	36,5

Technical data for ventilators LKK 125/1

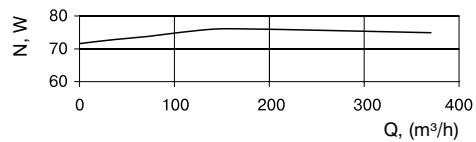
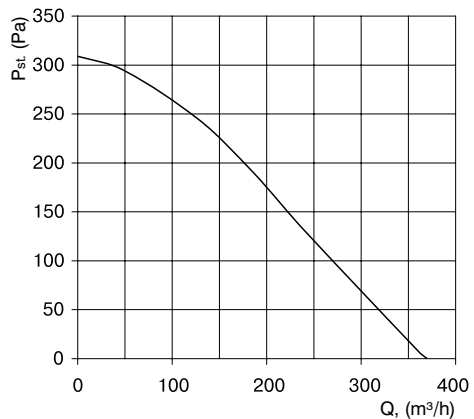

LKK 125/1 acoustic characteristics										
Operation mode, Pa	Sound level LPa, dBA	Total level, LPs, dB	Sound pressure level (Lps, dB) in octave-frequency band, Hz							
			63	125	250	500	1000	2000	4000	8000
Suction side noise	180	68,91	76,7	74,6	71,6	67	59,8	60,1	51,6	50,1
Noise through casing	180	50,95	69,8	69,7	49,6	42,6	47	45,8	43,1	36,6

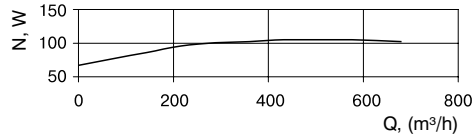
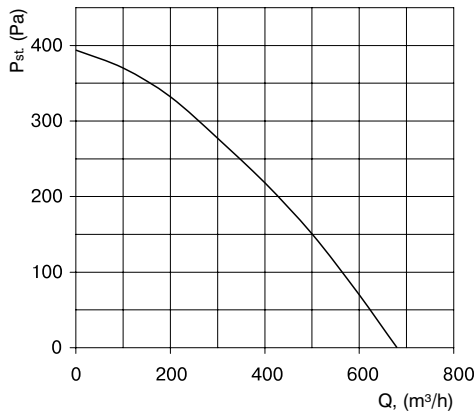
Technical data for ventilators LKK 160/1

LKK 160/1 acoustic characteristics

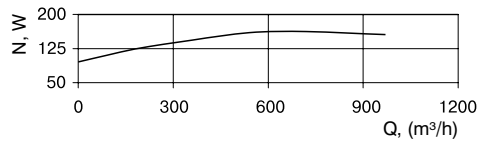
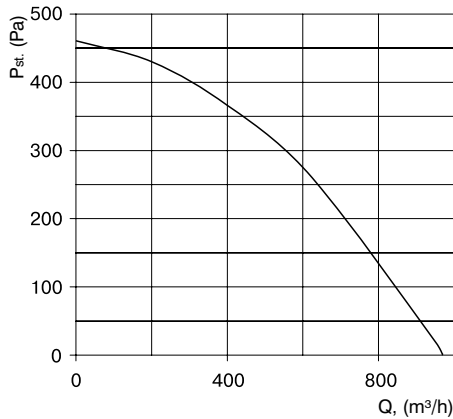
Operation mode, Pa	Sound level LPa, dBA	Total level, LPs, dB	Sound pressure level (Lps, dB) in octave-frequency band, Hz							
			63	125	250	500	1000	2000	4000	8000
Suction side noise	310	73,91	81,7	79,6	76,6	72	64,8	65,1	56,6	55,1
Noise through casing	310	59,95	78,8	58,6	51,6	56	54,8	52,1	45,6	44,1

Technical data for ventilators LKK 200/1

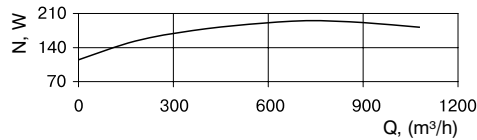
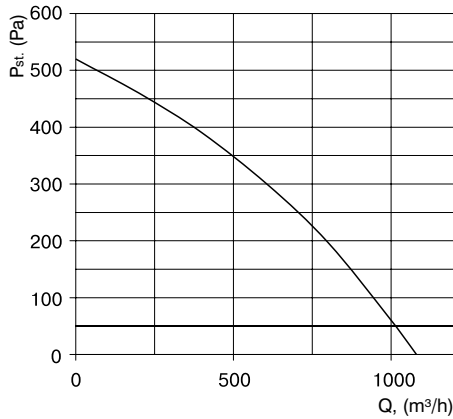
LKK 200/1 acoustic characteristics

Operation mode, Pa	Sound level LPa, dBA	Total level, LPs, dB	Sound pressure level (Lps, dB) in octave-frequency band, Hz							
			63	125	250	500	1000	2000	4000	8000
Suction side noise	355	72,91	80,7	78,6	75,6	71	63,8	64,1	55,6	54,1
Noise through casing	355	58,95	77,8	57,6	50,6	55	53,8	51,1	44,6	43,1

Technical data for ventilators LKK 250/1

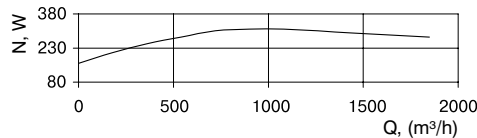
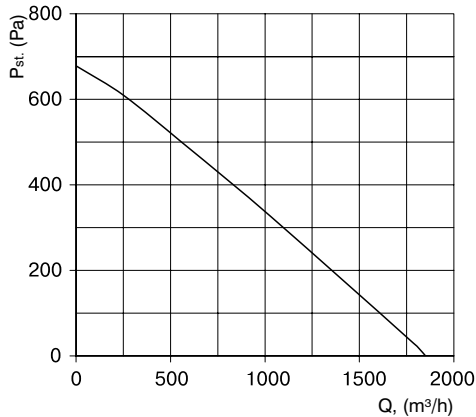
LKK 250/1 acoustic characteristics

Operation mode, Pa	Sound level LPa, dBA	Total level, LPs, dB	Sound pressure level (Lps, dB) in octave-frequency band, Hz							
			63	125	250	500	1000	2000	4000	8000
Suction side noise	380	74,91	83,2	79,6	78,1	73	66,5	65,1	58	55,1
Noise through casing	380	56,06	75,29	53,6	48,1	52	51,5	47,1	42	38,1

Technical data for ventilators LKK 315/1

LKK 315/1 acoustic characteristics

Operation mode, Pa	Sound level LPa, dBA	Total level, LPs, dB	Sound pressure level (Lps, dB) in octave-frequency band, Hz							
			63	125	250	500	1000	2000	4000	8000
Suction side noise	355	76,91	84,7	82,6	79,6	75	67,8	68,1	59,6	58,1
Noise through casing	355	56,95	75,8	55,6	48,6	53	51,8	49,1	42,6	41,1

RADIAL VENTILATORS FOR RECTANGULAR CHANNELS LVR WITH FORWARD INCLINED BLADES

General information

Channel radial ventilators LVR are meant for shifting the air and other nonaggressive nonexplosive gas mixtures. Temperature range of the shifting air is between -30° and $+40^{\circ}$ C.

Ventilators are adjusted directly into the rectangular channel of the air duct system. Ventilators can function in any position.



Construction and materials

LVR ventilators are fitted with asynchronous 1-phase and 3-phase motor with outer rotor and forward-curved blades. The ventilator wheel is positioned in a spiral pressure casing.

All the electric motors have an overheating protection provided by a heat contact inside the winding. The heat contacts outlets are to be connected up to the external motor protection device.

Case and ventilator impeller are made of steel galvanized sheet.

The electric motor case has a class IP 54 insulation. Winding is extra protected from moisture.

Applied materials and technologies allow to achieve more than 50 000 hours of ventilator endurance without additional service.

Capacity control

Capacity control of the LVR ventilators is implemented by changing the supplied voltage (transformer, phase, tiristor regulators) or frequency (frequency regulators).

Indication

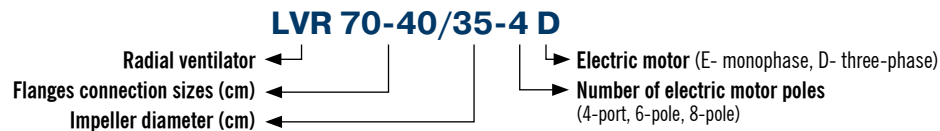

Dimension-types and basic technical information

Dimension type	Ventilator indication	Max. air consumption, m ³ /h	Max., full pressure, Pa	Revolutions at max. efficiency, min. ⁻¹	Electromotor voltage, V	Max. electric capacity, kW	Max. current, A	Mass, kg
40-20	LVR 40-20/20-4E	1198	240,0	1410	220	0,295	1,8	13,4
	LVR 40-20/20-4D	1248	258,5	1390	380	0,317	0,51	12,8
50-25	LVR 50-25/22-4E	1640	316,8	1418	220	0,475	2,3	18,1
	LVR 50-25/22-4D	1930	314,5	1428	380	0,516	1,1	18,1
	LVR 50-25/22-6D	1380	139,3	952	380	0,225	0,46	16
50-30	LVR 50-30/25-4E	2302	375,7	1390	220	0,821	3,7	22,8
	LVR 50-30/25-4D	2570	391,1	1461	380	0,938	2,2	22,5
	LVR 50-30/25-6D	1811	179,2	930	380	0,355	0,92	18,8
60-30	LVR 60-30/28-4E	2489	488,8	1370	220	1,15	5,1	31,7
	LVR 60-30/28-4D	3562	494,7	1415	380	1,74	2,6	31,5
	LVR 60-30/28-6D	2576	224,9	955	380	0,580	1,58	25,8
60-35	LVR 60-35/31-4D	4510	631,6	1415	380	2,48	4,1	38,9
	LVR 60-35/31-6D	3680	282,4	930	380	0,94	1,8	31,2
70-40	LVR 70-40/35-4D	5787	776,7	1422	380	3,35	6	62
	LVR 70-40/35-6D	4040	380,1	925	380	1,1	2	43,5
	LVR 70-40/35-8D	3672	213,4	670	380	0,654	1,4	44,5
80-50	LVR 80-50/40-4D	6822	1020	1415	380	4,98	8,1	78
	LVR 80-50/40-6D	7360	501,2	945	380	2,81	5,1	71
	LVR 80-50/40-8D	4700	306,2	701	380	1,24	2,29	57,1
90-50	LVR 90-50/45-4D	6558	1544,3	1265	380	4,92	8,3	96
	LVR 90-50/45-6D	9213	671,2	930	380	3,75	6,8	96
	LVR 90-50/45-8D	7815	383,2	690	380	1,85	3,8	93

Dimensions and weight

Indication	Dimensions, mm									
	A	B	C	D	E	F	G	H	I	J
LVR 40-20/20-4E LVR 40-20/20-4D	400	200	420	220	440	240	281	500	180	9
LVR 50-25/22-4E LVR 50-25/22-4D LVR 50-25/22-6D	500	250	520	270	540	290	331	530	196	9
LVR 50-30/25-4E LVR 50-30/25-4D LVR 50-30/25-6D	500	300	520	320	540	340	381	565	206	9
LVR 60-30/28-4E LVR 60-30/28-4D LVR 60-30/28-6D	600	300	620	320	640	340	381	642	232	9
LVR 60-35/31-4D LVR 60-35/31-6D	600	350	620	370	640	390	431	720	256	9
LVR 70-40/35-4D LVR 70-40/35-6D LVR 70-40/35-8D	700	400	720	420	740	440	481	780	280	9
LVR 80-50/40-4D LVR 80-50/40-6D LVR 80-50/40-8D	800	500	820	520	840	540	581	885	306	9
LVR 90-50/45-4D LVR 90-50/45-6D LVR 90-50/45-8D	900	500	930	530	960	560	591	985	362	13

LVR 40-20 - LVR 90-50

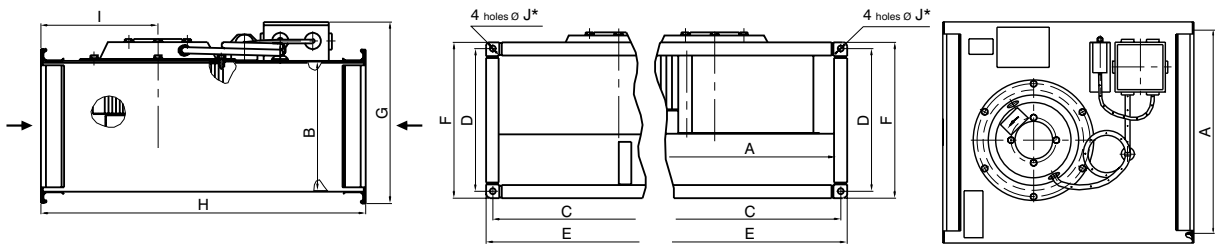
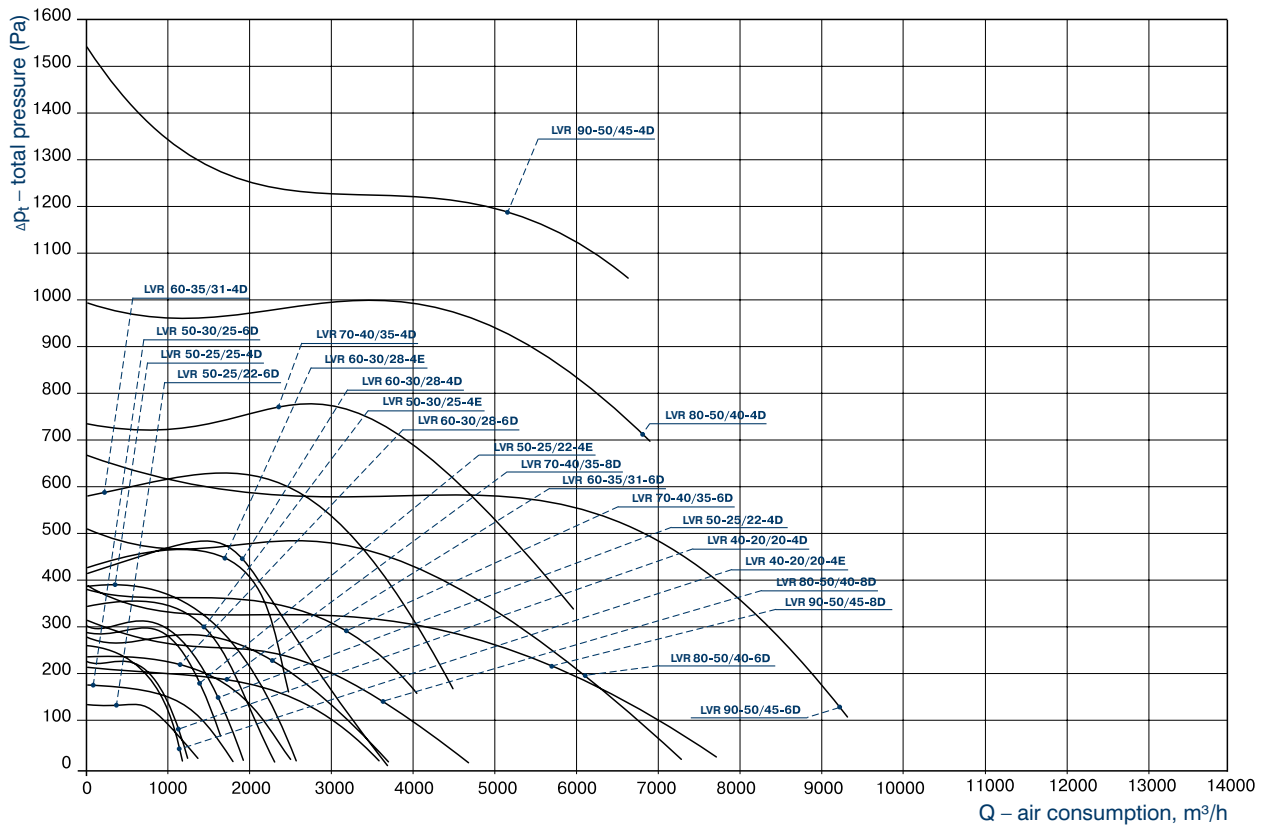
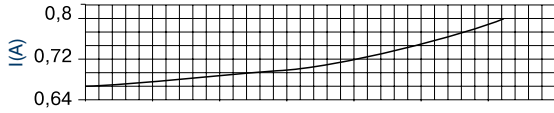
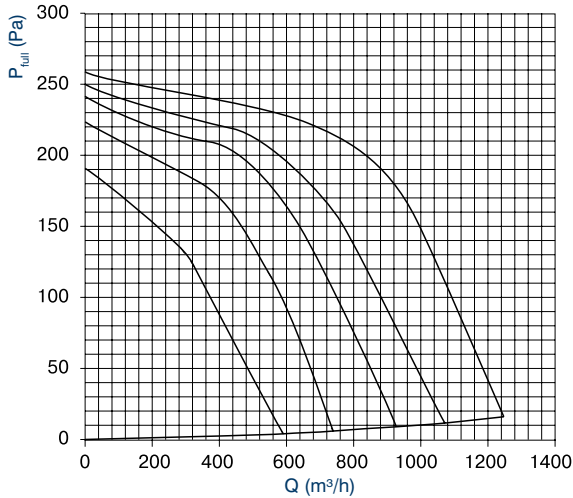

Diagram for quick selection



Technical data

Technical data of ventilators LVR 40-20/20-4D



	Q, m³/h	Ps, Pa	Pv, Pa	N, kW	h	n, rpm
Voltage U – 380 V						
1	0	258,5	258,5	0,102	0	1470
2	662,6	220,7	223,8	0,17	0,242	1390
3	985,3	149,2	156,2	0,241	0,177	1310
4	1248,3	0	16,0	0,317	0,056	1220
Voltage U – 280 V						
1	0	249,6	249,6	0,072	0	1440
2	438,6	216,1	218,1	0,125	0,210	1340
3	760,3	148,1	152,6	0,221	0,160	1297
4	1070,4	0	12,0	0,238	0,043	1009
Voltage U – 230 V						
1	0	241,9	241,9	0,051	0	1412
2	370,8	209,3	218,1	0,880	0,198	1321
3	640,4	147,2	152,6	0,153	0,110	1198
4	930,2	0	12,0	0,178	0,035	889
Voltage U – 180 V						
1	0	223,5	223,5	0,042	0	1331
2	340,2	179,9	180,9	0,720	0,156	1232
3	550,7	113,2	115,7	0,101	0,090	980
4	739,1	0	6,0	0,130	0,020	730
Voltage U – 140 V						
1	0	191,1	191,1	0,031	0	1270
2	290,1	132,1	133,1	0,049	0,140	1110
3	320,0	120,4	123,4	0,065	0,080	740
4	590,3	0,0	4,0	0,088	0,011	592

Acoustic characteristics of ventilators LVR 40-20/20-4D

Operation mode Pv, Pa	Sound level LPa, dBA	Summed level, Lps, dB	Sound pressure level (Lpi, dB) in octave-frequency band, Hz									
			63	125	250	500	1000	2000	4000	8000		
Suction side noise	35	210	63,3	68,4	53,0	54,9	53,9	54,4	52,6	51,8	51,0	48,6
	35	210	71,5	75,1	56,7	58,0	58,2	61,1	60,8	59,8	59,9	58,1
Discharge side noise	35	210	69,2	74,0	58,3	57,4	61,9	60,3	61,6	57,9	55,8	51,0
	35	210	77,6	80,7	63,0	64,2	67,7	67,0	69,9	66,4	65,5	62,3
Noise through casing	35	210	54,4	66,7	57,8	58,7	52,3	47,6	46,2	44,3	43,5	42,4
	35	210	58,4	71,0	61,5	63,4	54,7	51,0	49,6	47,8	46,6	45,4

Technical data of ventilators LVR 40-20/20-4E

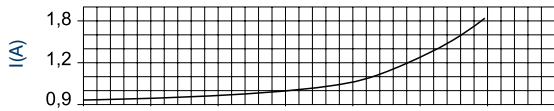
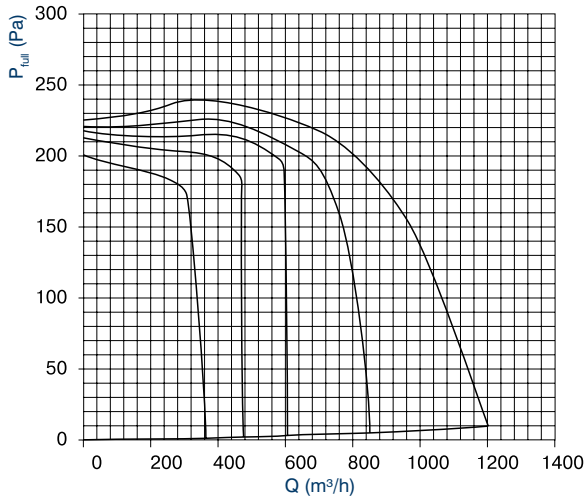

	Q, m³/h	Ps, Pa	Pv, Pa	N, kW	h	n, rpm
Voltage U – 220 V						
1	0	225,5	225,5	0,128	0	1473
2	719	211,7	215,4	0,188	0,230	1410
3	963	147,2	153,8	0,233	0,177	1360
4	1198	0	9,7	0,295	0,050	1242
Voltage U – 180 V						
1	0	221,0	221,0	0,090	0	1450
2	639,0	199,8	203,0	0,142	0,210	1380
3	758,3	155,4	159,4	0,168	0,120	1210
4	849,0	0	4,9	0,230	0,042	880
Voltage U – 160 V						
1	0	218,0	218,0	0,073	0	1440
2	580,0	194,0	198,0	0,120	0,190	1340
3	595,0	185,5	189,0	0,132	0,092	1298
4	605,4	0	3,1	0,187	0,038	640
Voltage U – 130 V						
1	0	213,0	213,0	0,059	0	1419
2	460,3	184,0	187,0	0,093	0,170	1310
3	466,8	171,8	179,3	0,102	0,076	1280
4	472,3	0	2,0	0,120	0,029	517
Voltage U – 105 V						
1	0	201,0	201,0	0,047	0	1390
2	256,0	183,0	183,4	0,056	0,156	1329
3	305,4	173,0	173,8	0,072	0,063	1238
4	363,0	0,0	1,1	0,084	0,019	400

Acoustic characteristics of ventilators LVR 40-20/20-4E

Operation mode Pv, Pa	Sound level LPa, dBA	Summed level, Lps, dB	Sound pressure level (Lpi, dB) in octave-frequency band, Hz									
			63	125	250	500	1000	2000	4000	8000		
Suction side noise	35	210	66,88	70,5	53,2	54,4	57,0	57,2	56,4	55,8	54,4	52,0
	35	210	71,3	74,7	58,4	57,7	57,7	62,3	60,7	60,4	60,1	58,2
Discharge side noise	35	210	72,9	76,9	58,2	60,2	63,9	62,8	64,3	61,1	59,1	54,9
	35	210	74,8	81,6	63,1	67,2	67,2	67,3	70,3	66,5	65,3	62,7
Noise through casing	35	210	58,9	69,5	58,9	60,6	57,4	50,1	50,1	48,7	47,8	46,2
	35	210	62,1	71,4	57,7	62,7	57,3	52,2	52,8	51,0	48,9	46,1

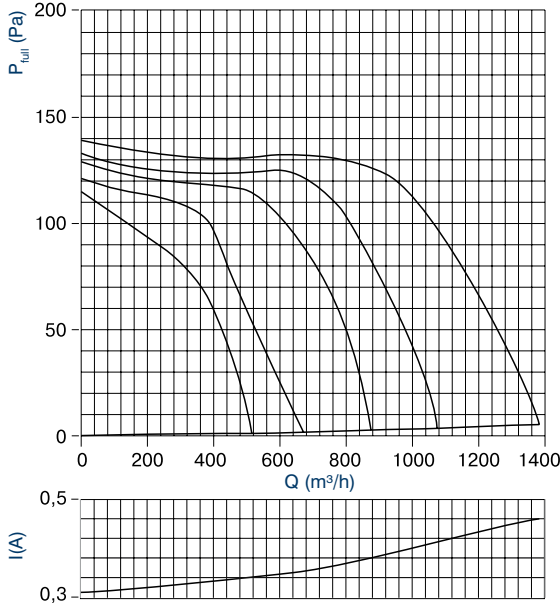
Technical data of ventilators LVR 50-25/22-6D

	Q, m³/h	Ps, Pa	Pv, Pa	N, kW	h	n, rpm
Voltage U – 380 V						
1	0	139,3	139,3	0,07	0	1010
2	740	129,1	131,4	0,115	0,311	952
3	920	120,1	123,2	0,184	0,231	887
4	1380	0	5,2	0,225	0,106	830
Voltage U – 280 V						
1	0	133,2	133,2	0,040	0	980
2	575	123,1	125,1	0,071	0,296	910
3	780	105,4	107,4	0,174	0,153	796
4	1072	0	3,4	0,206	0,094	663
Voltage U – 230 V						
1	0	129,2	129,2	0,034	0	955
2	498	114,5	116,3	0,052	0,271	870
3	689	82,5	84,6	0,093	0,102	675
4	873	0	2,6	0,118	0,087	539
Voltage U – 180 V						
1	0	121,3	121,3	0,028	0	923
2	390,6	98,4	99,4	0,047	0,240	826
3	438	80,0	81,3	0,062	0,092	535
4	670	0	1,5	0,110	0,073	415
Voltage U – 140 V						
1	0	115,1	115,1	0,024	0	875
2	251	87,4	88,0	0,032	0,190	798
3	385	63,2	64,0	0,046	0,078	438
4	514	0	1,0	0,067	0,051	340

Acoustic characteristics of ventilators LVR 50-25/22-6D

Operation mode Pv, Pa	Sound level LPa, dBA	Summed level, LPs, dB	Sound pressure level (Lpi, dB) in octave-frequency band, Hz								
			63	125	250	500	1000	2000	4000	8000	
Suction side noise	140	61,8	67,9	49,2	52,3	62,1	53,0	50,7	49,7	48,0	41,5
	30	68,3	74,6	56,1	59,8	70,3	58,2	57,0	56,5	55,3	50,3
Discharge side noise	140	66,0	70,1	55,7	53,1	58,0	59,9	56,8	53,3	50,6	42,4
	30	73,0	77,3	61,1	60,3	68,4	67,0	64,0	61,7	59,9	53,9
Noise through casing	140	53,0	64,0	54,1	56,2	52,2	46,2	42,2	40,5	37,6	37,2
	30	58,9	69,2	59,2	60,4	62,7	51,2	47,3	45,3	41,4	37,3

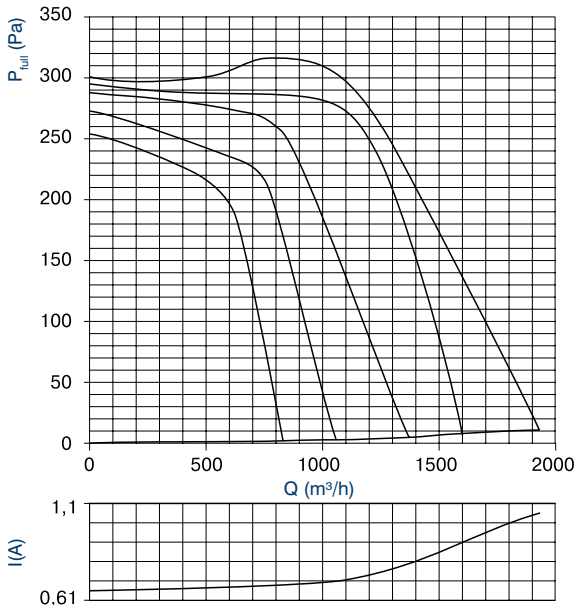
Technical data of ventilators LVR 50-25/22-4D

	Q, m³/h	Ps, Pa	Pv, Pa	N, kW	h	n, rpm
Voltage U – 380 V						
1	0	300,1	300,1	0,148	0	1480
2	980	307,5	310,4	0,284	0,298	1428
3	1286	244,3	249,2	0,362	0,246	1390
4	1930	0	10,8	0,516	0,081	1305
Voltage U – 280 V						
1	0	294,2	294,2	0,087	0	1465
2	718,0	285,0	286,0	0,175	0,287	1403
3	1230,0	234,4	238,4	0,293	0,124	1210
4	1598,9	0	6,8	0,480	0,076	1087
Voltage U – 230 V						
1	0	287,1	287,1	0,079	0	1450
2	611,0	272,1	273,1	0,132	0,279	1380
3	820,0	254,3	256,3	0,187	0,110	1296
4	1371,0	0	4,8	0,382	0,067	950
Voltage U – 180 V						
1	0	272,0	272,0	0,061	0	1410
2	578,0	235,3	236,3	0,120	0,268	1283
3	760,0	211,2	212,4	0,143	0,103	1187
4	1058,0	0	2,8	0,259	0,056	745
Voltage U – 140 V						
1	0	253,2	253,2	0,055	0	1355
2	461,3	219,3	220,3	0,098	0,197	1190
3	620,3	187,4	189,0	0,116	0,095	1120
4	830,1	0,0	2,0	0,171	0,048	587

Acoustic characteristics of ventilators LVR 50-25/22-4D

Operation mode Pv, Pa	Sound level LPa, dBA	Summed level, LPs, dB	Sound pressure level (Lpi, dB) in octave-frequency band, Hz								
			63	125	250	500	1000	2000	4000	8000	
Suction side noise	315	70,2	76,5	62,1	66,3	53,9	59,8	60,9	59,4	57,1	52,9
	100	76,7	81,6	68,2	73,2	67,2	65,1	66,9	65,5	64,7	59,5
Discharge side noise	315	75,7	80,1	64,1	65,7	66,0	67,5	67,9	62,7	61,0	57,0
	100	82,4	86,2	69,0	71,2	71,1	71,9	75,4	70,8	69,7	64,9
Noise through casing	315	60,8	73,7	62,1	64,2	59,5	51,5	49,4	47,2	45,2	43,7
	100	63,9	76,2	65,1	68,0	63,0	55,4	51,9	48,1	44,7	43,5

Technical data of ventilators LVR 50-25/22-4E

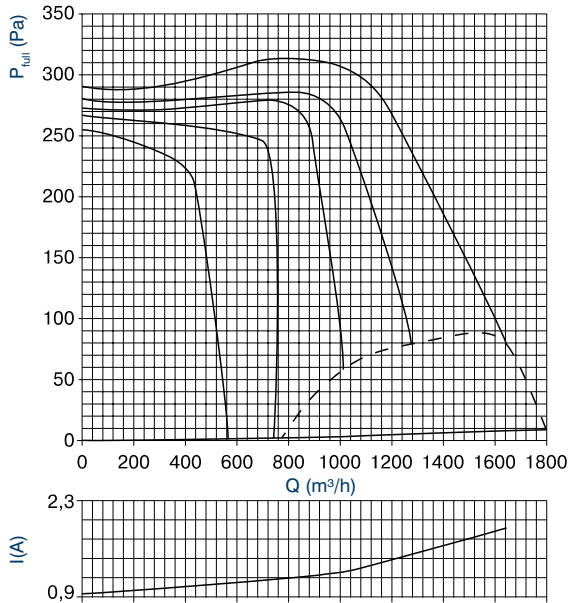

	Q, m³/h	Ps, Pa	Pv, Pa	N, kW	h	n, rpm
Voltage U – 220 V						
1	0	291,0	291,0	0,155	0	1479
2	969	306,9	309,6	0,265	0,315	1418
3	1195	264,5	268,7	0,315	0,283	1385
4	1640	70,9	78,8	0,475	0,076	1248
Voltage U – 180 V						
1	0	281,1	281,1	0,118	0	1469
2	831,0	284,1	286,1	0,210	0,301	1399
3	1015,0	253,5	256,5	0,310	0,197	1276
4	1272,0	74	79,2	0,376	0,069	1075
Voltage U – 160 V						
1	0	273,2	273,2	0,097	0	1459
2	732,0	277,7	279,7	0,183	0,295	1378
3	890,0	243,8	246,0	0,298	0,162	1243
4	1009,0	55	58,1	0,321	0,053	875
Voltage U – 130 V						
1	0	267,4	267,4	0,086	0	1428
2	617,0	250,2	251,2	0,148	0,187	1321
3	695,3	244,9	246,4	0,199	0,132	1201
4	740,0	0	2,0	0,224	0,046	540
Voltage U – 105 V						
1	0	255,3	255,3	0,077	0	1400
2	353,0	231,0	231,4	0,096	0,131	1318
3	428,4	214,1	214,7	0,113	0,092	1187
4	564,0	0,0	1,0	0,143	0,032	421

Acoustic characteristics of ventilators LVR 50-25/22-4E

Operation mode Pv, Pa	Sound level LPa, dBA	Summed level, Lps, dB	Sound pressure level (Lpi, dB) in octave-frequency band, Hz								
			63	125	250	500	1000	2000	4000	8000	
Suction side noise	315	67,7	75,1	60,0	62,3	57,9	58,2	56,0	54,3	52,2	47,7
	70	74,4	78,1	58,8	63,7	64,5	62,8	64,3	64,4	62,6	59,2
Discharge side noise	315	74,0	78,4	62,6	62,0	63,4	66,7	65,6	61,6	59,2	54,4
	70	81,4	84,4	67,0	68,9	70,0	68,6	74,4	68,4	68,3	64,2
Noise through casing	315	60,8	72,8	60,6	64,2	55,3	48,9	47,3	46,8	43,1	40,3
	70	63,0	76,9	64,8	69,5	59,7	53,2	50,1	47,8	45,1	42,6

Technical data of ventilators LVR 50-30/25-6D

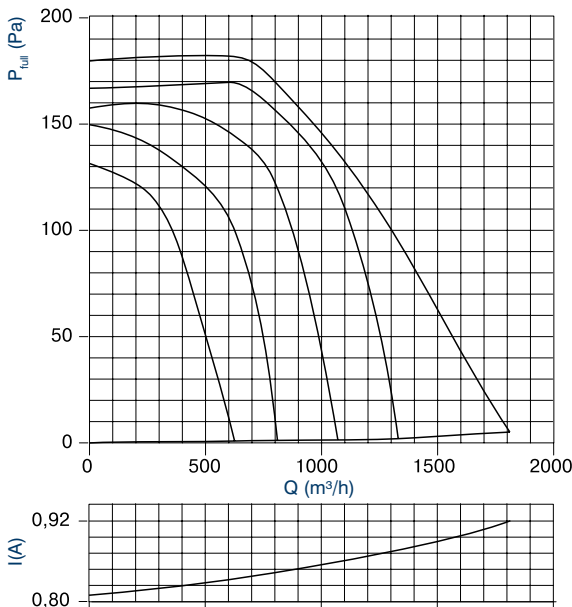

	Q, m³/h	Ps, Pa	Pv, Pa	N, kW	h	n, rpm
Voltage U – 380 V						
1	0	179,2	179,2	0,121	0	975
2	901	155,9	157,5	0,189	0,209	930
3	1265	102,8	106,1	0,246	0,151	883
4	1811	0	5,1	0,355	0,064	780
Voltage U – 280 V						
1	0	166,4	166,4	0,096	0	956
2	830,2	152,2	153,2	0,108	0,196	890
3	1132,0	98,4	99,9	0,189	0,104	786
4	1330,0	0	2,0	0,226	0,053	605
Voltage U – 230 V						
1	0	157,1	157,1	0,052	0	949
2	680,8	139,0	139,4	0,093	0,183	840
3	787,5	124,2	124,9	0,123	0,098	736
4	1070,0	0	1,4	0,160	0,042	485
Voltage U – 180 V						
1	0	149,3	149,3	0,047	0	915
2	348,1	133,4	133,8	0,082	0,168	831
3	632,0	97,3	97,8	0,097	0,083	710
4	810,0	0	1,0	0,100	0,036	380
Voltage U – 140 V						
1	0	131,1	131,1	0,035	0	845
2	272,1	115,0	115,1	0,054	0,142	778
3	450,6	68,3	68,9	0,063	0,067	623
4	625,0	0,0	0,9	0,078	0,023	310

Acoustic characteristics of ventilators LVR 50-30/25-6D

Operation mode Pv, Pa	Sound level LPa, dBA	Summed level, Lps, dB	Sound pressure level (Lpi, dB) in octave-frequency band, Hz								
			63	125	250	500	1000	2000	4000	8000	
Suction side noise	160	62,4	69,0	54,1	62,9	57,7	52,4	54,0	51,6	50,6	45,7
	55	69,3	73,4	56,4	65,0	62,0	61,3	60,6	58,9	57,9	52,4
Discharge side noise	160	68,9	73,8	58,0	65,1	58,6	62,4	58,9	57,3	55,5	45,9
	55	76,0	79,3	91,3	68,1	63,9	71,0	66,3	64,7	64,1	55,4
Noise through casing	160	54,4	67,1	56,8	58,3	51,9	46,9	46,3	44,1	42,3	40,6
	55	59,1	68,3	57,9	58,8	56,2	52,2	50,3	47,6	45,8	42,8

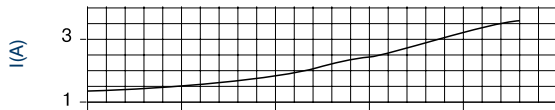
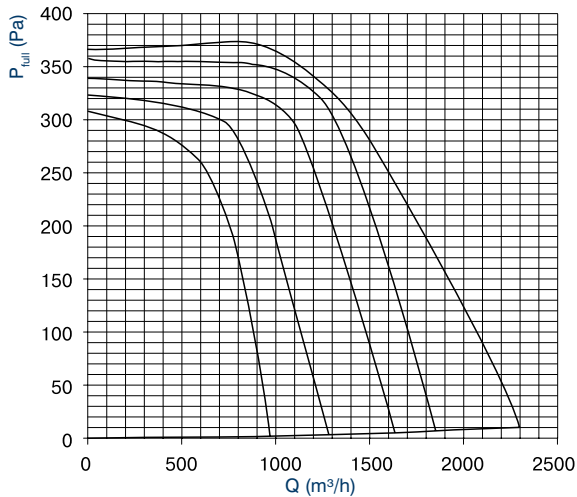
Technical data of ventilators LVR 50-30/25-4E

	Q, m³/h	Ps, Pa	Pv, Pa	N, kW	h	n, rpm
Voltage U – 380 V						
1	0	364,3	364,3	0,260	0	1470
2	1229,6	333,3	336,3	0,430	0,267	1390
3	1497,3	277,5	282,0	0,500	0,235	1360
4	2302	0,0	10,2	0,821	0,064	1160
Voltage U – 280 V						
1	0	355,2	355,2	0,190	0	1446
2	1039,0	341,1	343,1	0,338	0,232	1342
3	1238,0	315,3	319,6	0,483	0,152	1156
4	1852,0	0	6,9	0,630	0,058	940
Voltage U – 230 V						
1	0	337,5	337,5	0,170	0	1420
2	915,0	319,1	321,1	0,227	0,194	1320
3	114,5	288,2	291,3	0,395	0,083	1140
4	1635,4	0	5,0	0,530	0,047	830
Voltage U – 180 V						
1	0	322,4	322,4	0,130	0	1400
2	725,2	296,4	297,4	0,217	0,183	1301
3	983,7	196,3	198,5	0,298	0,056	1126
4	1283,6	0	3,1	0,380	0,038	662
Voltage U – 140 V						
1	0	307,2	307,2	0,105	0	1360
2	587,0	262,1	263,1	0,170	0,132	1200
3	780,3	185,4	186,6	0,197	0,063	1112
4	970,7	0,0	1,9	0,260	0,021	505

Acoustic characteristics of ventilators LVR 50-30/25-4E

Operation mode Pv, Pa	Sound level LPa, dBA	Summed level, LPs, dB	Sound pressure level (Lpi, dB) in octave-frequency band, Hz								
			63	125	250	500	1000	2000	4000	8000	
Suction side noise	325	73,0	79,1	62,0	71,1	65,1	62,0	62,5	61,8	61,1	55,7
	100	78,9	81,9	62,8	74,6	69,6	67,4	67,7	68,3	67,5	63,6
Discharge side noise	325	79,1	83,6	65,7	75,8	68,0	71,1	71,1	66,5	66,7	59,9
	100	86,5	89,2	68,3	78,5	74,1	76,8	78,4	74,7	74,4	68,0
Noise through casing	325	63,0	77,1	61,8	70,8	59,1	53,4	51,6	50,5	48,6	47,3
	100	65,5	77,9	64,5	69,0	64,1	55,7	54,0	51,5	49,7	46,8

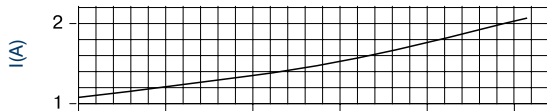
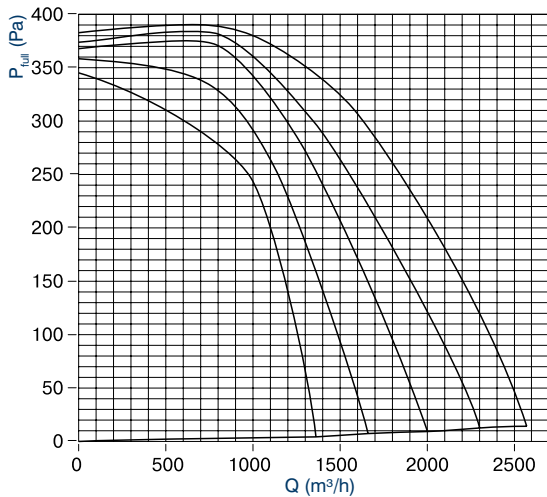
Technical data of ventilators LVR 50-30/25-4D

	Q, m³/h	Ps, Pa	Pv, Pa	N, kW	h	n, rpm
Voltage U – 220 V						
1	0	381,7	381,7	0,153	0	1485
2	992	377,5	379,5	0,325	0,322	1461
3	1577	305,4	310,4	0,495	0,275	1431
4	2570	0	14,2	0,938	0,109	1391
Voltage U – 180 V						
1	0	372,8	372,8	0,142	0	1473
2	801	378	380,4	0,278	0,287	1422
3	1350	294	298,3	0,384	0,231	1398
4	2300	0	12,6	0,789	0,098	1223
Voltage U – 160 V						
1	0	366,8	366,8	0,126	0	1460
2	789	368,4	370,4	0,27	0,232	1390
3	1280	273,5	276,8	0,352	0,189	1216
4	2001	0,00	9,30	0,721	0,087	1090
Voltage U – 130 V						
1	0	357,4	357,4	0,116	0	1440
2	763	330,2	331,8	0,134	0,217	1338
3	1132	250,5	253,2	0,312	0,158	1099
4	1660	0	7,4	0,532	0,079	900
Voltage U – 105 V						
1	0	344,2	344,2	0,098	0	1395
2	680	290,2	291,6	0,201	0,161	1270
3	986	244,5	246,6	0,253	0,141	898
4	1361	0,00	4,3	0,36	0,062	735

Acoustic characteristics of ventilators LVR 50-30/25-4D

Operation mode Pv, Pa	Sound level LPa, dBA	Summed level, LPs, dB	Sound pressure level (Lpi, dB) in octave-frequency band, Hz								
			63	125	250	500	1000	2000	4000	8000	
Suction side noise	370	74,1	79,0	64,1	72,3	64,8	63,0	64,7	62,6	63,0	57,7
	115	82,4	85,7	65,8	78,1	72,5	68,8	72,6	71,8	71,8	67,9
Discharge side noise	370	80,5	84,5	66,3	75,4	70,1	72,1	72,4	68,6	68,6	62,6
	115	89,5	91,8	71,9	82,1	77,2	79,1	81,1	78,0	77,6	72,0
Noise through casing	370	66,3	75,8	62,3	67,0	61,7	55,6	53,2	51,3	50,1	46,0
	115	69,1	79,7	68,4	70,7	65,9	58,9	60,9	55,6	53,9	49,7

Technical data of ventilators LVR 60-30/28-6D

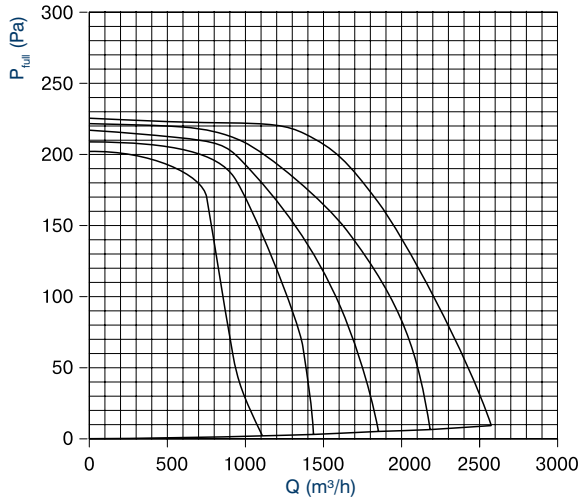

	Q, m³/h	Ps, Pa	Pv, Pa	N, kW	h	n, rpm
Voltage U – 380 V						
1	0	224,9	224,9	0,143	0	985
2	1382,0	211,2	213,9	0,280	0,293	955
3	1848,7	161,5	166,4	0,378	0,226	931
4	2575,7	0	9,4	0,580	0,023	875
Voltage U – 280 V						
1	0	221,1	221,1	0,080	0	978
2	983,0	207,0	208,6	0,176	0,289	930
3	1650,0	143,2	146,3	0,273	0,201	825
4	2184,0	0	6,6	0,450	0,019	770
Voltage U – 230 V						
1	0	216,5	216,5	0,071	0	965
2	972,0	194,6	195,6	0,168	0,210	901
3	1612,3	89,8	91,9	0,267	0,191	798
4	1853,2	0	5,3	0,362	0,018	647
Voltage U – 180 V						
1	0	208,3	208,3	0,063	0	940
2	926,7	182,8	183,8	0,115	0,197	889
3	1368,8	62,6	64,7	0,156	0,183	654
4	1437,0	0	3,2	0,243	0,016	500
Voltage U – 140 V						
1	0	201,6	201,6	0,052	0	925
2	753,0	168,9	169,4	0,106	0,186	853
3	920,3	58,3	59,4	0,138	0,172	567
4	1110,0	0	2,2	0,151	0,015	390

Acoustic characteristics of ventilators LVR 60-30/28-6D

Operation mode Pv, Pa	Sound level LPa, dBA	Summed level, LPs, dB	Sound pressure level (Lpi, dB) in octave-frequency band, Hz									
			63	125	250	500	1000	2000	4000	8000		
Suction side noise	10	215	64,2	70,2	58,8	65,1	57,1	53,4	56,1	51,9	52,2	43,3
	10	215	75,1	79,6	66,3	71,7	66,9	64,8	66,5	63,1	63,7	59,6
Discharge side noise	10	215	69,5	75,6	61,2	69,6	61,2	61,4	60,2	56,3	57,3	46,9
	10	215	80,6	85,2	69,6	78,5	70,5	72,1	71,5	67,9	68,6	62,6
Noise through casing	10	215	58,8	68,5	56,8	60,5	54,7	52,0	47,2	44,6	39,4	35,6
	10	215	65,0	78,8	64,3	69,1	61,8	56,2	53,7	50,9	49,3	45,5

Technical data of ventilators LVR 60-30/28-4D

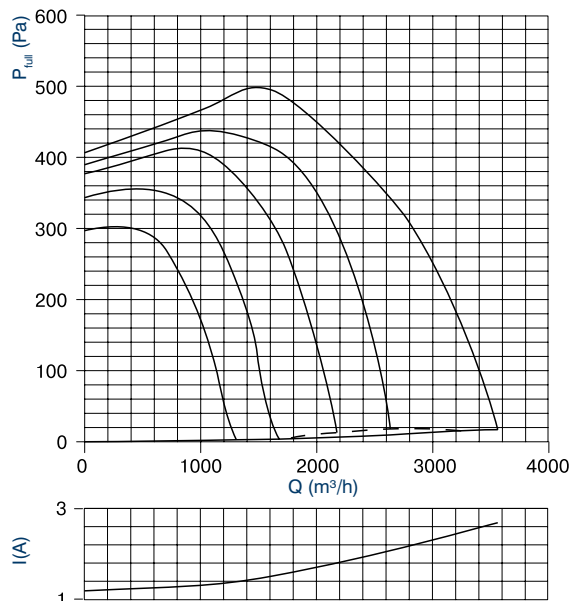

	Q, m³/h	Ps, Pa	Pv, Pa	N, kW	h	n, rpm
Voltage U – 380 V						
1	0	406,73	406,73	0,26	0	1475
2	1618	491,03	494,72	0,60	0,369	1415
3	2785	301,36	312,31	1,18	0,206	1295
4	3562	0	17,2	1,74	0,019	1160
Voltage U – 280 V						
1	0	389,87	389,87	0,23	0	1450
2	1346	427,80	430,36	0,49	0,330	1350
3	1679	404,62	408,60	0,61	0,312	1288
4	2636	8,43	18,24	1,17	0,011	860
Voltage U – 230 V						
1	0	377,23	377,23	0,22	0	1420
2	1187	389,87	391,86	0,42	0,310	1295
3	1738	265,53	269,80	0,64	0,203	1089
4	2176	6,32	13,01	0,87	0,009	700
Voltage U – 180 V						
1	0	343,51	343,51	0,20	0	1370
2	1269	238,14	241,52	0,41	0,294	985
3	1489	120,12	123,25	0,51	0,100	776
4	1679	0,00	3,9	0,570	0,003	545
Voltage U – 140 V						
1	0	297,14	297,14	0,19	0	1272
2	710	267,64	268,35	0,26	0,207	1110
3	1144	94,83	96,68	0,34	0,090	665
4	1309	0,00	3,0	0,36	0,005	433

Acoustic characteristics of ventilators LVR 60-30/28-4D

Operation mode Pv, Pa	Sound level LPa, dBA	Summed level, LPs, dB	Sound pressure level (Lpi, dB) in octave-frequency band, Hz									
			63	125	250	500	1000	2000	4000	8000		
Suction side noise	30	480	76,6	81,9	68,0	77,1	67,7	62,9	68,0	65,3	64,7	61,2
	30	480	83,6	86,9	68,2	80,4	73,8	71,2	74,9	73,1	71,6	69,0
Discharge side noise	30	480	81,7	87,3	67,7	81,3	71,1	72,6	73,5	69,3	69,8	64,7
	30	480	90,3	93,8	75,1	86,7	80,9	80,2	81,5	79,0	78,5	73,6
Noise through casing	30	480	65,6	79,7	66,2	74,0	59,5	54,8	55,7	53,2	50,2	47,9
	30	480	72,1	83,1	70,1	78,7	68,2	59,8	60,5	58,5	58,0	54,1

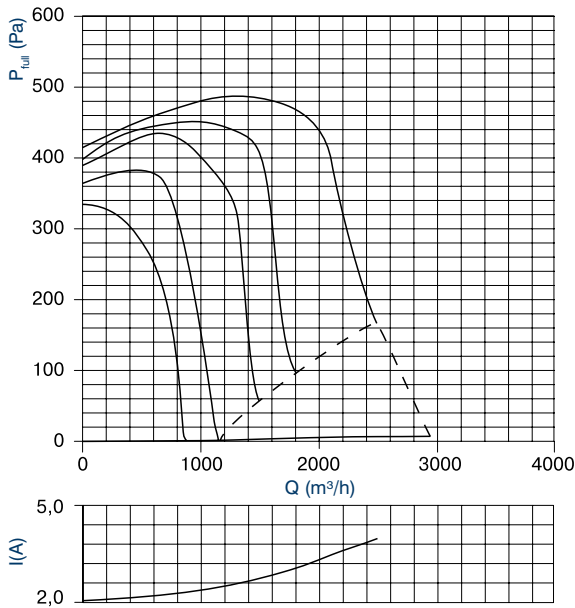
Technical data of ventilators LVR 60-30/28-4E

	Q, m³/h	Ps, Pa	Pv, Pa	N, kW	h	n, rpm
Voltage U – 220 V						
1	0,00	414,83	414,83	0,330	0	1470
2	1674,08	477,77	477,77	0,650	0,342	1370
3	2104,93	389,56	393,85	0,830	0,279	1283
4	2488,44	157,93	166,72	1,150	0,100	1049
Voltage U – 180 V						
1	0,0	398,0	398,0	0,250	0	1456
2	1296,7	435,9	438,3	0,470	0,336	1331
3	1479,4	410,6	413,7	0,530	0,321	1279
4	1826,6	84,2	89,0	0,800	0,056	760
Voltage U – 160 V						
1	0,00	389,6	389,6	0,215	0	953
2	955,53	408,51	409,81	0,350	0,311	882
3	1307,80	317,97	320,40	0,470	0,248	753
4	1482,91	56,86	59,98	0,610	0,041	633
Voltage U – 130 V						
1	0,00	364,29	364,29	0,183	0	700
2	655,16	372,72	373,33	0,250	0,272	649
3	1109,82	31,59	33,34	0,395	0,026	576
4	1151,2	0	1,5	0,498	0,022	455
Voltage U – 105 V						
1	0,00	334,81	334,81	0,155	0	1340
2	546,44	269,54	269,96	0,210	0,195	1120
3	849,47	18,95	19,98	0,260	0,018	560
4	881,0	0,0	1,0	0,296	0,020	380

Acoustic characteristics of ventilators LVR 60-30/28-4E

Operation mode Pv, Pa	Sound level LPa, dBA	Summed level, LPS, dB	Sound pressure level (Lpi, dB) in octave-frequency band, Hz								
			63	125	250	500	1000	2000	4000	8000	
Suction side noise	485	74,5	80,2	65,3	76,0	65,9	60,9	67,8	62,9	62,2	58,8
	160	77,7	81,6	64,6	75,6	68,0	65,8	69,9	67,0	66,3	60,9
Discharge side noise	485	79,3	85,5	66,2	81,3	70,0	71,4	71,9	67,8	67,6	61,6
	160	82,8	87,7	67,2	82,4	72,5	73,6	73,5	71,4	71,2	66,3
Noise through casing	485	62,8	77,5	65,2	71,9	56,4	49,0	49,7	45,9	45,6	41,0
	160	64,8	78,9	65,4	74,3	60,6	51,2	51,4	50,2	48,0	43,5

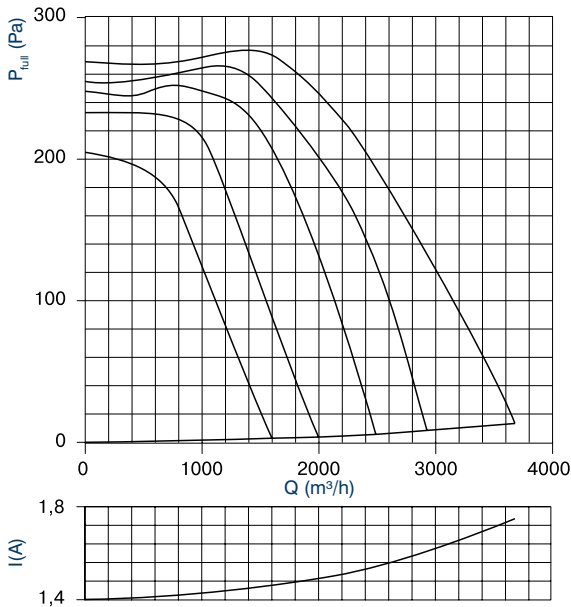
Technical data of ventilators LVR 60-35/31-6D

	Q, m³/h	Ps, Pa	Pv, Pa	N, kW	h	n, rpm
Voltage U – 380 V						
1	0	269,1	269,1	0,203	0	974
2	1659,2	268,0	270,9	0,348	0,359	930
3	2235,3	219,8	224,9	0,488	0,286	890
4	3680,0	0,0	13,5	0,94	0,017	753
Voltage U – 280 V						
1	0	252,2	255,2	0,156	0	955
2	1450,2	254,0	256,3	0,280	0,330	910
3	2305,1	156,4	161,7	0,420	0,253	745
4	2927,0	0,0	8,6	0,650	0,011	600
Voltage U – 230 V						
1	0	248,2	248,2	0,105	0	937
2	985,4	247,7	248,8	0,191	0,315	870
3	1403,3	229,3	231,2	0,268	0,211	634
4	2489,1	0,0	5,8	0,510	0,010	532
Voltage U – 180 V						
1	0	233,1	233,1	0,080	0	900
2	970,0	214,7	215,7	0,096	0,290	804
3	1100,3	193,4	195,4	0,185	0,197	570
4	1998,6	0,0	3,9	0,315	0,008	420
Voltage U – 140 V						
1	0	205,1	205,1	0,075	0	850
2	730,0	184,9	185,6	0,089	0,195	548
3	1005,4	138,1	139,9	0,102	0,098	480
4	1600,0	0,0	3,1	0,210	0,005	350

Acoustic characteristics of ventilators LVR 60-35/31-6D

Operation mode Pv, Pa	Sound level LPa, dBA	Summed level, LPS, dB	Sound pressure level (Lpi, dB) in octave-frequency band, Hz								
			63	125	250	500	1000	2000	4000	8000	
Suction side noise	275	67,8	76,3	62,4	71,2	61,6	55,2	58,0	55,6	54,4	48,8
	40	76,2	81,1	65,0	74,2	68,4	63,9	66,1	64,5	64,3	60,4
Discharge side noise	275	73,6	81,7	62,9	74,8	64,6	63,5	62,4	60,0	58,8	50,4
	40	81,2	85,6	67,0	78,5	71,3	73,7	71,6	68,6	68,7	63,1
Noise through casing	275	64,7	72,3	63,0	65,7	54,6	49,2	47,7	45,6	43,6	41,7
	40	64,2	76,4	66,8	69,2	61,6	55,8	51,6	49,6	49,5	44,7

Technical data of ventilators LVR 60-35/31-4D

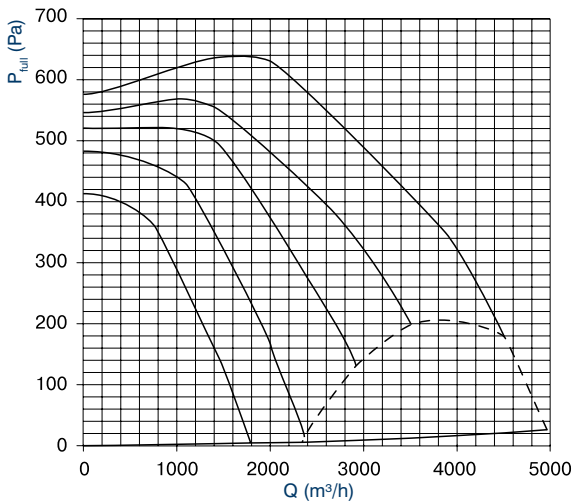

	Q, m ³ /h	Ps, Pa	Pv, Pa	N, kW	h	n, rpm
Voltage U – 380 V						
1	0	576,5	576,5	0,345	0	1478
2	1991,0	627,5	631,6	0,900	0,388	1415
3	3879,0	334,0	349,4	1,925	0,196	1279
4	4510,0	157,1	178,3	2,480	0,110	1256
Voltage U – 280 V						
1	0	546,5	546,5	0,295	0	1450
2	1384,0	554,9	556,9	0,600	0,356	1371
3	2694,0	373,4	381,0	1,200	0,238	1180
4	3512,0	186,1	198,7	1,810	0,013	1108
Voltage U – 230 V						
1	0	521,1	521,1	0,280	0	1422
2	1455,0	491,6	493,8	0,610	0,327	1288
3	2397,0	270,1	276,0	1,035	0,178	1030
4	2921,0	122,3	131,2	1,395	0,011	920
Voltage U – 180 V						
1	0	483,2	483,2	0,260	0	1371
2	1100,0	428,3	429,6	0,470	0,279	1220
3	2008,0	160,4	164,5	0,795	0,115	798
4	2368,0	8,5	14,3	1,092	0,009	615
Voltage U – 140 V						
1	0	413,5	413,5	0,250	0	1282
2	778,0	356,6	357,2	0,345	0,224	1150
3	1455,0	141,4	143,6	0,500	0,116	703
4	1793,0	0,0	4,7	0,636	0,007	475

Acoustic characteristics of ventilators LVR 60-35/31-4D

Operation mode Pv, Pa	Sound level LPa, dBA	Summed level, LPs, dB	Sound pressure level (Lpi, dB) in octave-frequency band, Hz								
			63	125	250	500	1000	2000	4000	8000	
Suction side noise	630	77,6	82,9	69,0	78,1	68,7	63,9	69,0	66,3	65,7	62,2
	180	86,7	89,8	72,1	83,3	74,2	63,9	77,7	76,1	74,6	72,0
Discharge side noise	630	81,6	87,2	67,6	81,2	72,5	63,5	73,4	69,2	69,7	64,6
	180	92,3	95,8	77,1	88,7	82,2	73,7	83,5	81,0	80,5	75,6
Noise through casing	630	69,5	83,6	70,1	78,0	58,7	49,2	59,6	57,1	54,1	51,8
	180	73,2	84,2	71,2	79,8	60,9	55,8	61,6	59,6	59,1	55,2

Technical data of ventilators LVR 70-40/35-8D

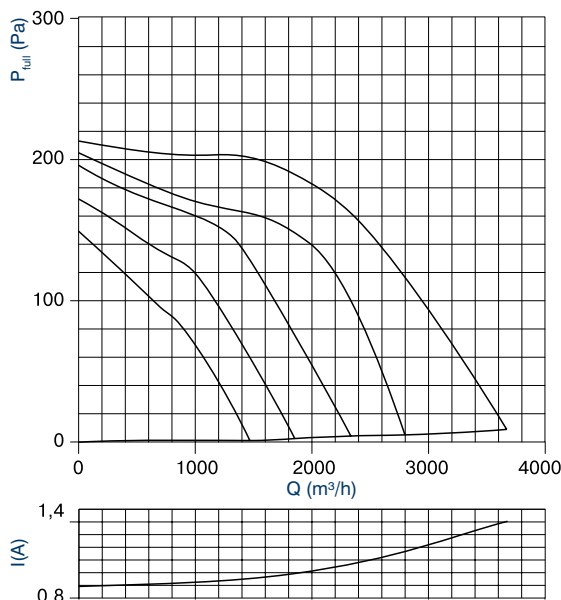

	Q, m ³ /h	Ps, Pa	Pv, Pa	N, kW	h	n, rpm
Voltage U – 380 V						
1	0	213,4	213,4	0,170	0	720
2	1820	189,1	191,2	0,320	0,346	670
3	2350	157	161,2	0,431	0,254	603
4	3672	0	9,1	0,654	0,196	528
Voltage U – 280 V						
1	0	205,1	205,1	0,103	0	708
2	1410	161,8	163,2	0,208	0,294	630
3	1980	137,2	141,1	0,375	0,213	531
4	2800	0	5,2	0,410	0,175	387
Voltage U – 230 V						
1	0	196,3	196,3	0,08	0	690
2	1250	149,1	150,1	0,186	0,227	597
3	1453	129,1	131,2	0,232	0,181	478
4	2336	0	4,4	0,280	0,132	345
Voltage U – 180 V						
1	0	172,4	172,4	0,074	0	658
2	850	128,6	129,2	0,113	0,205	565
3	980	120,4	121,6	0,155	0,131	342
4	1855	0	2,6	0,178	0,117	270
Voltage U – 140 V						
1	0	149,6	149,6	0,065	0	595
2	702	95,2	95,6	0,081	0,193	491
3	828	86,3	87,3	0,097	0,101	296
4	1470	0	1,2	0,110	0,098	220

Acoustic characteristics of ventilators LVR 70-40/35-8D

Operation mode Pv, Pa	Sound level LPa, dBA	Summed level, LPs, dB	Sound pressure level (Lpi, dB) in octave-frequency band, Hz								
			63	125	250	500	1000	2000	4000	8000	
Suction side noise	180	64,0	69,8	55,8	57,8	56,3	51,6	52,3	52,2	51,5	41,8
	15	72,0	76,0	63,4	62,5	61,8	60,4	60,4	60,4	59,1	54,9
Discharge side noise	180	69,6	76,3	64,0	68,2	61,8	63,3	58,5	56,4	56,4	46,5
	15	78,3	82,1	67,8	70,7	67,5	70,3	67,4	64,8	65,3	58,3
Noise through casing	180	56,7	70,5	62,2	58,6	55,4	44,3	42,2	39,8	36,5	32,5
	15	60,5	72,4	64,1	60,8	57,5	50,4	47,0	46,1	42,4	37,8

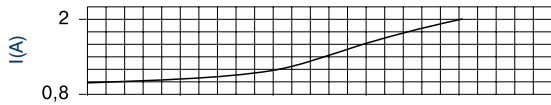
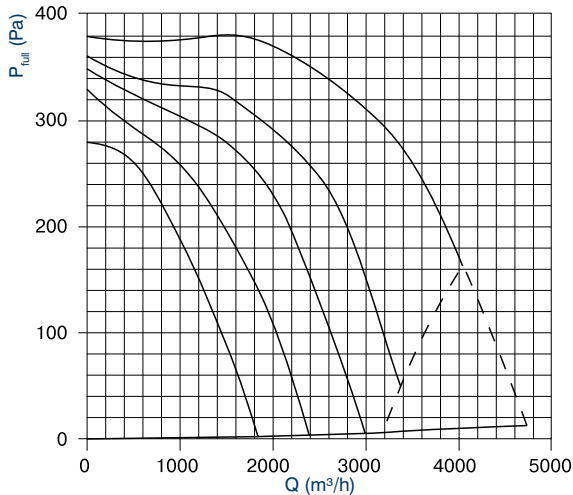
Technical data of ventilators LVR 70-40/35-6D

	Q, m³/h	Ps, Pa	Pv, Pa	N, kW	h	n, rpm
Voltage U – 380 V						
1	0	380,1	380,1	0,203	0	980
2	1990	369,1	371,4	0,520	0,378	925
3	3128	296,7	301,2	0,750	0,283	830
4	4040	153,3	163,4	1,100	0,204	770
Voltage U – 230 V						
1	0	361,7	361,7	0,159	0	960
2	1544	321,3	322,6	0,368	0,322	870
3	2508	242,6	246,7	0,632	0,221	783
4	3374	42,5	49,7	0,821	0,158	557
Voltage U – 230 V						
1	0	349,6	349,6	0,139	0	938
2	1480	280,3	281,3	0,321	0,296	870
3	2115	211,1	213,1	0,453	0,201	560
4	2991	0	5,2	0,610	0,136	430
Voltage U – 180 V						
1	0	330,2	330,2	0,129	0	900
2	1174	240,3	241,2	0,296	0,224	746
3	1870	134,6	136	0,328	0,197	452
4	2390	0	3,6	0,401	0,112	347
Voltage U – 140 V						
1	0	280,1	280,1	0,115	0	840
2	990	189,6	190,4	0,180	0,185	650
3	1320	125,4	127,2	0,21	0,154	356
4	1840	0,00	2,2	0,254	0,097	280

Acoustic characteristics of ventilators LVR 70-40/35-6D

Operation mode Pv, Pa	Sound level LPa, dBA	Summed level, LPs, dB	Sound pressure level (Lpi, dB) in octave-frequency band, Hz								
			63	125	250	500	1000	2000	4000	8000	
Suction side noise	350	70,3	79,8	69,2	66,3	61,4	55,5	58,4	57,5	57,5	50,0
	175	77,4	81,4	68,1	68,0	65,4	63,3	65,2	64,5	64,0	59,5
Discharge side noise	350	75,1	82,2	67,3	72,8	67,4	65,8	64,5	61,0	60,2	52,3
	175	81,6	85,5	68,4	75,4	71,2	74,4	71,3	68,7	68,6	62,1
Noise through casing	350	61,6	75,5	66,9	64,4	55,2	52,0	48,1	48,3	43,5	40,9
	175	64,2	76,5	66,8	66,2	59,2	55,7	51,9	48,6	45,2	44,6

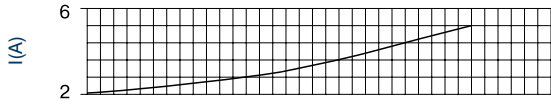
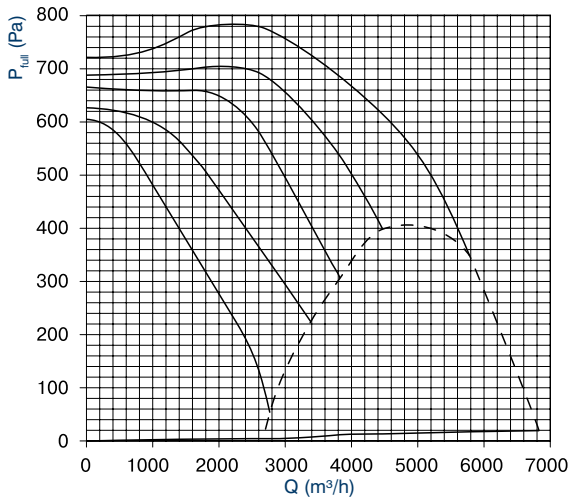
Technical data of ventilators LVR 70-40/35-4D

	Q, m³/h	Ps, Pa	Pv, Pa	N, kW	h	n, rpm
Voltage U – 380 V						
1	0,0	722,0	722,0	0,61	0	1480
2	2690,4	772,4	776,7	1,47	0,395	1422
3	4461,6	604,5	616,2	2,52	0,303	1350
4	5786,7	331	348,4	3,35	0,187	1282
Voltage U – 230 V						
1	0,0	688,5	688,5	0,58	0	1450
2	2614,6	688,5	692,5	1,35	0,373	1340
3	3909,1	512,2	521,1	2,04	0,275	1218
4	4473,2	385,3	398,7	2,94	0,024	965
Voltage U – 230 V						
1	0,00	666,15	666,15	0,565	0	1417
2	2581,40	581,82	585,72	1,305	0,322	1240
3	3773,05	311,99	320,31	1,905	0,176	1040
4	3889	294,7	306,6	2,34	0,020	875
Voltage U – 180 V						
1	0,00	627,12	627,12	0,53	0	1360
2	1456,11	556,53	557,77	0,815	0,277	1249
3	1797,46	505,93	507,82	0,935	0,271	1189
4	3387,6	217,16	224,6	1,545	0,016	698
Voltage U – 140 V						
1	0,00	605,4	605,4	0,490	0	1262
2	1004,81	480,64	481,23	0,595	0,226	1179
3	2269,18	219,24	222,25	0,888	0,158	780
4	2770,07	48,92	53,4	1,005	0,013	530

Acoustic characteristics of ventilators LVR 70-40/35-4D

Operation mode Pv, Pa	Sound level LPa, dBA	Summed level, LPs, dB	Sound pressure level (Lpi, dB) in octave-frequency band, Hz								
			63	125	250	500	1000	2000	4000	8000	
Suction side noise	750	81,3	87,1	73,7	78,8	72,7	65,4	73,3	69,7	67,2	65,0
	300	90,2	93,1	76,3	82,0	78,8	75,0	81,2	80,5	77,3	73,6
Discharge side noise	750	88,4	92,9	74,1	84,8	79,6	79,5	80,0	75,7	74,0	68,5
	300	96,0	99,0	76,6	87,4	85,6	85,8	88,5	85,5	83,1	78,3
Noise through casing	750	68,1	83,4	73,9	74,5	63,5	56,4	58,5	51,8	49,8	47,1
	300	74,4	86,8	74,2	79,1	71,9	62,9	64,3	58,4	56,1	56,1

Technical data of ventilators LVR 80-50/40-8D

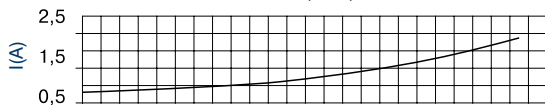
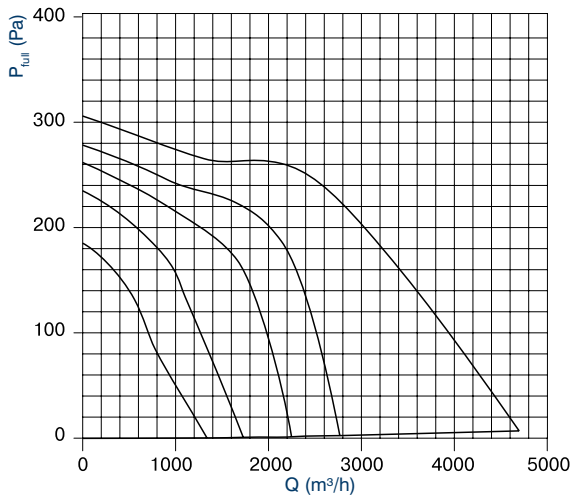

	Q, m³/h	Ps, Pa	Pv, Pa	N, kW	h	n, rpm
Voltage U – 380 V						
1	0	306,2	306,2	0,243	0	730
2	2138	252,6	261,1	0,510	0,343	701
3	3053	195,3	198,4	0,790	0,257	576
4	4700	0	7,1	1,240	0,196	480
Voltage U – 280 V						
1	0	278,6	278,6	0,162	0	710
2	1645	222,8	224,1	0,325	0,266	650
3	2140	185,4	187,3	0,521	0,184	496
4	2769	0	2,6	0,650	0,151	305
Voltage U – 230 V						
1	0	262,1	262,1	0,144	0	690
2	1080	210,2	211,2	0,230	0,211	648
3	1670	167,55	168,7	0,364	0,162	325
4	2250	0	1,5	0,440	0,117	241
Voltage U – 180 V						
1	0	235,2	235,2	0,130	0	660
2	800	180,7	181,4	0,175	0,196	610
3	1106	133,25	134,1	0,238	0,132	297
4	1730	0	1	0,275	0,098	190
Voltage U – 140 V						
1	0	185,4	185,4	0,112	0	581
2	560	131,7	131,8	0,131	0,178	505
3	780	84,86	85,1	0,142	0,106	234
4	1340	0	0,4	0,150	0,081	151

Acoustic characteristics of ventilators LVR 80-50/40-8D

Operation mode Pv, Pa	Sound level LPa, dBA	Summed level, LPs, dB	Sound pressure level (Lpi, dB) in octave-frequency band, Hz								
			63	125	250	500	1000	2000	4000	8000	
Suction side noise	250	66,0	75,1	65,3	60,9	59,2	55,5	55,2	54,2	52,0	44,8
	20	70,8	75,2	61,6	58,5	61,8	60,3	60,3	59,8	57,3	50,8
Discharge side noise	250	71,5	78,0	63,3	68,5	66,0	66,0	59,3	58,0	56,4	48,2
	20	76,2	80,8	63,3	69,3	69,9	68,8	64,7	63,4	61,5	54,4
Noise through casing	250	59,9	71,6	64,6	60,7	55,6	51,5	47,0	43,8	40,5	36,0
	20	62,9	72,6	64,2	62,3	56,8	54,6	50,2	47,1	42,9	38,6

Technical data of ventilators LVR 80-50/40-6D

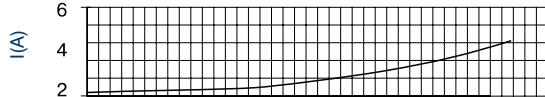
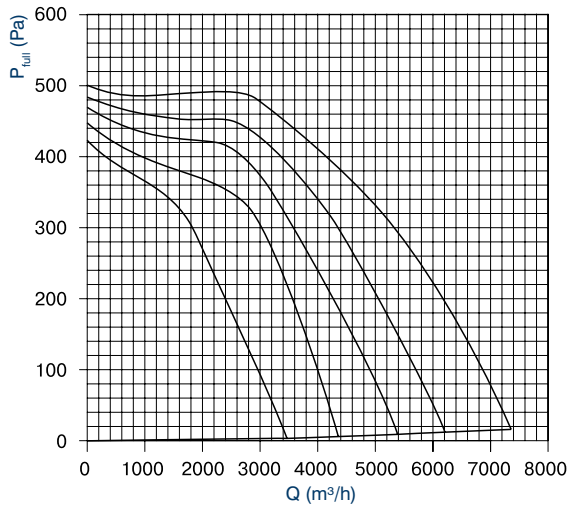

	Q, m³/h	Ps, Pa	Pv, Pa	N, kW	h	n, rpm
Voltage U – 380 V						
1	0	501,2	501,2	0,449	0	990
2	2930	480	482,2	1,020	0,361	945
3	5120	316,5	321,1	1,870	0,267	886
4	7360	0	16,1	2,810	0,204	829
Voltage U – 280 V						
1	0	484,3	484,3	0,280	0	976
2	2500	449,2	451,2	0,741	0,345	932
3	4220	313	317,1	0,987	0,238	794
4	6210	0	12,2	1,960	0,197	705
Voltage U – 230 V						
1	0	470	470	0,259	0	965
2	2250	418,4	420,3	0,620	0,33	905
3	3113	358,1	362,1	0,786	0,199	718
4	5390	0	9,1	1,530	0,176	626
Voltage U – 180 V						
1	0	448,1	448,1	0,236	0	940
2	1937	369,6	371,2	0,52	0,274	860
3	2850	321	324,6	0,63	0,178	642
4	4360	0	6	1,21	0,151	510
Voltage U – 140 V						
1	0	423,6	423,6	0,198	0	920
2	1770	307,4	308,7	0,410	0,233	770
3	2240	224,8	228,1	0,561	0,163	534
4	3470	0	3,4	0,692	0,122	400

Acoustic characteristics of ventilators LVR 80-50/40-6D

Operation mode Pv, Pa	Sound level LPa, dBA	Summed level, LPs, dB	Sound pressure level (Lpi, dB) in octave-frequency band, Hz								
			63	125	250	500	1000	2000	4000	8000	
Suction side noise	450	78,1	83,5	73,2	67,2	66,9	66,1	68,7	66,5	65,0	61,3
	60	86,6	89,8	76,4	75,5	74,8	75,2	77,7	75,7	72,6	70,0
Discharge side noise	450	85,3	89,4	69,8	79,1	75,1	78,3	74,8	71,8	71,3	66,0
	60	92,4	95,4	75,8	84,5	81,5	85,0	82,9	79,9	77,6	74,7
Noise through casing	450	65,7	79,2	71,1	72,7	58,6	57,3	52,2	50,6	49,5	47,1
	60	71,1	82,7	74,0	76,1	64,8	64,8	60,3	57,2	55,1	51,8

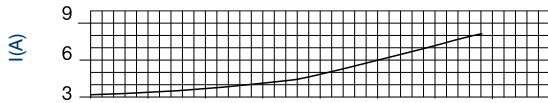
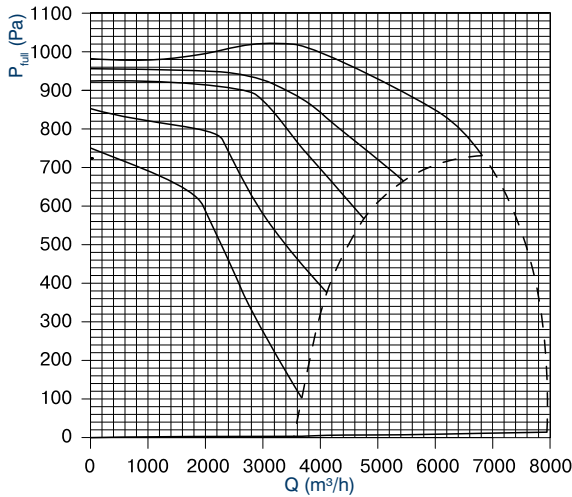
Technical data of ventilators LVR 80-50/40-4D

	Q, m³/h	Ps, Pa	Pv, Pa	N, kW	h	n, rpm
Voltage U = 380 V						
1	0	982,7	982,7	1,070	0	1470
2	3539	1016,4	1020,0	2,380	0,421	1415
3	6130	826,6	837,3	4,130	0,345	1345
4	6822	719,9	731,1	4,987	0,301	1310
Voltage U = 280 V						
1	0	956,6	956,6	0,901	0	1450
2	3300	918,2	921,4	2,132	0,356	1350
3	4100	821,7	826,3	2,842	0,328	1306
4	5450	657,9	665,3	3,530	0,296	1200
Voltage U = 230 V						
1	0	924,7	924,7	0,8	0	1430
2	2880	886,6	889,4	1,820	0,341	1306
3	3769	732,3	736,3	2,153	0,298	1213
4	4760	560,8	567,6	2,810	0,211	1200
Voltage U = 180 V						
1	0	853,2	853,2	0,75	0	1383
2	2300	770,3	772,4	1,51	0,312	1218
3	3152	545,1	548,5	1,96	0,221	1087
4	4115	370,1	376,1	2,11	0,187	885
Voltage U = 140 V						
1	0	751,1	751,1	0,58	0	1300
2	1960	599,5	601,3	1,134	0,286	1050
3	2638	378,2	381,2	1,34	0,193	983
4	3680	98,8	102,3	1,51	0,162	540

Acoustic characteristics of ventilators LVR 80-50/40-4D

Operation mode Pv, Pa	Sound level LPa, dBA	Summed level, LPs, dB	Sound pressure level (Lpi, dB) in octave-frequency band, Hz								
			63	125	250	500	1000	2000	4000	8000	
Suction side noise	1016	83,3	89,6	80,1	78,2	75,9	68,6	74,7	71,4	69,1	66,0
	740	89,1	93,0	83,6	82,2	76,7	74,2	81,1	78,7	76,2	74,7
Discharge side noise	1016	92,5	96,2	82,3	85,3	80,0	81,8	85,1	80,1	77,5	74,0
	740	95,6	98,5	83,0	87,2	82,9	84,6	86,9	83,0	81,2	78,1
Noise through casing	1016	71,8	86,8	78,3	77,6	64,4	60,2	58,9	56,1	55,4	54,2
	740	75,0	88,1	79,4	79,4	63,4	63,3	63,1	59,1	57,9	55,7

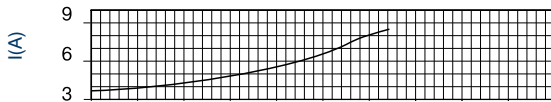
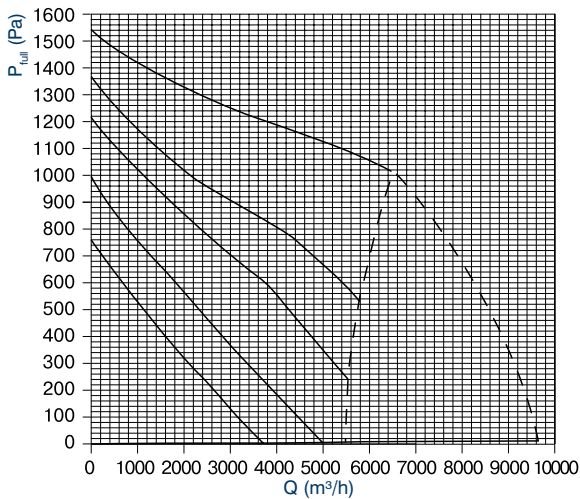
Technical data of ventilators LVR 90-50/45-4D

	Q, m³/h	Ps, Pa	Pv, Pa	N, kW	h	n, rpm
Voltage U = 380 V						
1	0	1544,3	1544,3	2,1	0	1395
2	5500	1081,4	1090	4,3	0,432	1265
3	5750	1061,1	1070,1	4,88	0,394	1216
4	6558	1014,0	1023,0	4,92	0,359	1201
Voltage U = 280 V						
1	0	1369,1	1369,1	1,510	0	1340
2	4400	774,9	780,2	3,110	0,387	1060
3	5110	639,7	646,3	3,321	0,331	1035
4	5815	525,8	534,2	3,690	0,298	910
Voltage U = 230 V						
1	0	1217,4	1217,4	1,31	0	1285
2	3580	622,1	625,2	2,350	0,322	960
3	4140	521,1	526,3	2,643	0,294	876
4	5540	233,8	241,1	2,830	0,233	655
Voltage U = 180 V						
1	0	997,1	997,1	1,063	0	1135
2	1540	653,2	655,2	1,42	0,296	1015
3	3210	324,8	328,7	1,64	0,231	751
4	4990	0	5,4	1,88	0,197	370
Voltage U = 140 V						
1	0	760,2	760,2	0,83	0	980
2	2290	265,7	266,7	1,050	0,233	618
3	2965	136,2	139,3	1,125	0,198	483
4	3710	0,0	3,2	1,161	0,162	280

Acoustic characteristics of ventilators LVR 90-50/45-4D

Operation mode Pv, Pa	Sound level LPa, dBA	Summed level, LPs, dB	Sound pressure level (Lpi, dB) in octave-frequency band, Hz								
			63	125	250	500	1000	2000	4000	8000	
Suction side noise	1010	85,7	93,5	85,9	76,6	77,3	73,3	75,2	74,3	72,3	68,6
	900	86,3	94,1	85,6	76,7	77,1	74,2	75,7	75,2	72,5	69,3
Discharge side noise	1010	91,6	97,4	87,9	85,1	82,5	82,5	82,8	79,1	76,2	72,7
	900	92,7	97,8	86,1	85,8	82,3	83,1	83,2	80,6	77,5	73,9
Noise through casing	1010	71,2	86,4	78,5	74,7	66,2	59,4	59,3	55,9	56,0	54,8
	900	73,7	86,9	79,4	74,8	67,0	60,0	61,7	59,9	62,5	58,9

Technical data of ventilators LVR 90-50/45-6D

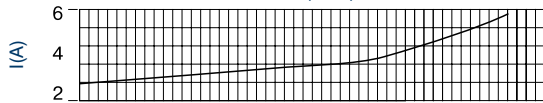
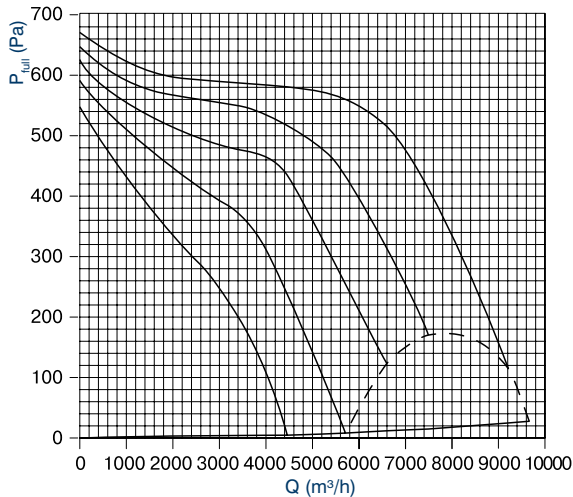

	Q, m ³ /h	Ps, Pa	Pv, Pa	N, kW	h	n, rpm
Voltage U – 380 V						
1	0	671,2	671,2	0,680	0	970
2	4430	576,8	581,1	1,761	0,351	930
3	5540	512,7	519,8	2,321	0,297	897
4	9213	89,6	114,6	3,752	0,210	825
Voltage U – 280 V						
1	0	647,6	647,6	0,571	0	952
2	3570,0	543,9	547,3	1,373	0,310	883
3	5410,0	455,7	464,6	1,932	0,265	798
4	7492,0	155,4	170,4	2,710	0,193	708
Voltage U – 230 V						
1	0	626,3	626,3	0,520	0	930
2	3496,0	473,2	476,1	1,287	0,289	832
3	4420,0	431,9	439,2	1,675	0,213	716
4	6600,0	111,3	123,4	2,294	0,171	625
Voltage U – 180 V						
1	0	591,8	591,8	0,461	0	900
2	3152,0	384,1	386,4	1,031	0,246	750
3	3980,0	309,1	315,2	1,353	0,198	631
4	5710,0	0	8,3	1,710	0,132	450
Voltage U – 140 V						
1	0	548,1	548,1	0,422	0	850
2	2555,0	290,0	291,2	0,755	0,192	650
3	3420,0	195,6	198,7	1,220	0,141	590
4	4460,0	0	4,8	1,053	0,098	355

Acoustic characteristics of ventilators LVR 90-50/45-6D

Operation mode Pv, Pa	Sound level LPa, dBA	Summed level, LPs, dB	Sound pressure level (Lpi, dB) in octave-frequency band, Hz								
			63	125	250	500	1000	2000	4000	8000	
Suction side noise	580	80,8	89,3	75,4	84,2	74,6	68,2	71,0	68,6	67,4	61,8
	120	91,2	96,1	80,0	89,2	83,4	78,9	81,1	79,5	79,3	75,4
Discharge side noise	580	86,6	94,7	75,9	87,8	77,6	76,5	75,4	73,0	71,8	63,4
	120	95,2	99,6	81,0	92,5	85,3	87,7	85,6	82,6	82,7	77,1
Noise through casing	580	67,7	75,3	66,0	68,7	57,6	52,2	50,7	48,6	46,6	44,7
	120	70,2	82,4	72,8	75,2	67,6	61,8	57,6	55,6	55,5	50,7

Technical data of ventilators LVR 90-50/45-8D

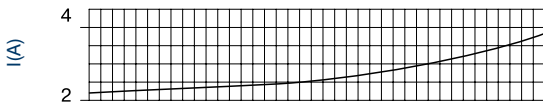
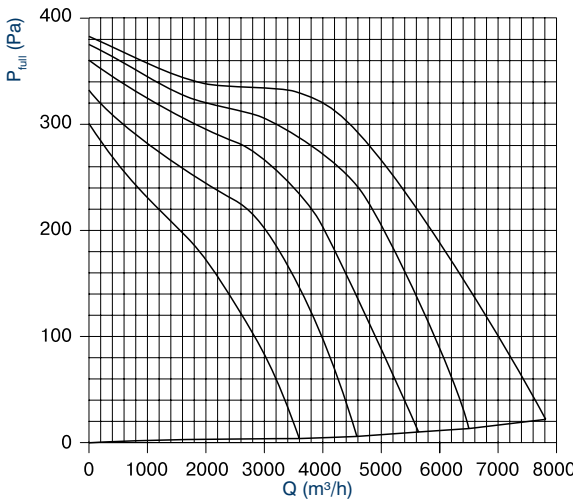

	Q, m ³ /h	Ps, Pa	Pv, Pa	N, kW	h	n, rpm
Voltage U – 380 V						
1	0	383,2	383,2	0,360	0	728
2	3531	329,5	331,1	0,810	0,431	690
3	5120	245,9	258	1,210	0,322	665
4	7815	0	22,1	1,850	0,253	600
Voltage U – 280 V						
1	0	375,6	375,6	0,273	0	720
2	2950	305,8	307,2	0,650	0,395	663
3	4670	226,6	236,2	0,843	0,299	535
4	6500	0	13,4	1,321	0,212	495
Voltage U – 230 V						
1	0	360,8	360,8	0,22	0	700
2	2530	282,1	283,1	0,511	0,346	640
3	3940	201,5	209,6	0,731	0,272	510
4	5640	0	10,2	1,078	0,183	430
Voltage U – 180 V						
1	0	360,8	332,6	0,195	0	680
2	2479	282,1	229,2	0,446	0,304	575
3	3255	201,5	181,1	0,573	0,238	465
4	4585	0	6	0,728	0,152	340
Voltage U – 140 V						
1	0	301,1	301,1	0,173	0	640
2	1680	193,1	193,6	0,310	0,287	538
3	2525	125,9	128,8	0,385	0,216	346
4	3600	0	4	0,472	0,122	281

Acoustic characteristics of ventilators LVR 90-50/45-8D

Operation mode Pv, Pa	Sound level LPa, dBA	Summed level, LPs, dB	Sound pressure level (Lpi, dB) in octave-frequency band, Hz								
			63	125	250	500	1000	2000	4000	8000	
Suction side noise	360	70,4	80,2	71,8	63,5	65,5	60,8	60,1	58,1	55,9	48,9
	50	81,8	87,3	78,5	73,6	73,1	72,4	71,8	70,8	67,7	63,8
Discharge side noise	360	75,6	83,5	71,1	70,7	72,4	66,4	65,2	62,2	58,1	51,1
	50	88,2	93,0	79,4	80,1	80,4	80,2	77,7	76,0	72,8	68,3
Noise through casing	360	62,8	74,8	68,3	63,1	55,8	51,6	50,7	48,2	51,6	45,8
	50	67,6	80,3	71,5	70,1	62,1	58,9	57,4	52,4	49,7	46,8

RADIAL VENTILATORS FOR RECTANGULAR CHANNELS LVP WITH BACKWARD INCLINED BLADES

General information

Channel radial ventilators LVP are meant for shifting the air and other nonaggressive nonexplosive gas mixtures. Maximum temperature of the shifting air is +40° C.

Ventilators are adjusted directly into the rectangular channel of the air duct system. Ventilators can function in any position.

Construction and materials

For the LVP ventilators light plastic impellers with backward-curved blades and asynchronous 3-phase motors are used. The impeller is "free" and is adjusted directly on a shaft of electric motor.

The lower panel of ventilator has a removable service hatch. The case of ventilator and the service panel are made of steel galvanized sheet.

LVP ventilators should be provided with current overheating protection.

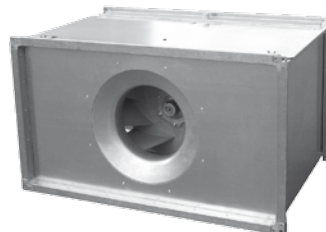

Capacity control

Changes in the capacity of LVP ventilators are implemented by the frequency rpm regulators.

Indication

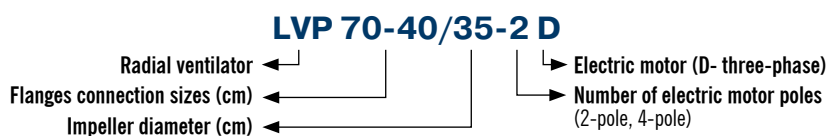

Dimension-types and basic technical information

Ventilator indication	Motor revolutions, min. ⁻¹	Motor voltage, V	Motor installed capacity, kW	Motor nominal current, A
LVP 40-20/18-2D	2720	3x230/ 3x400	0,25	0,66
LVP 50-25/20-2D	2720	3x230/ 3x400	0,25	0,66
LVP 50-25/22-2D	2740	3x230/ 3x400	0,55	1,33
LVP 50-30/22-2D	2740	3x230/ 3x400	0,55	1,33
LVP 50-30/25-2D	2780	3x230/ 3x400	0,75	1,67
LVP 60-30/25-2D	2780	3x230/ 3x400	0,75	1,67
LVP 60-30/28-2D	2840	3x230/ 3x400	1,1	2,5
LVP 60-35/28-2D	2840	3x230/ 3x400	1,1	2,5
LVP 60-35/31-2D	2840	3x230/ 3x400	1,5	3,45
LVP 70-40/31-2DM	2840	3x230/ 3x400	1,5	3,45
LVP 70-40/31-2D	2840	3x230/ 3x400	2,2	4,6
LVP 70-40/35-2D	2860	3x230/ 3x400	3,0	5,9
LVP 80-50/35-2D	2860	3x230/ 3x400	3,0	5,9
LVP 80-50/40-4D	1410	3x230/ 3x400	3,0	6,44
LVP 90-50/35-2D	2860	3x230/ 3x400	3,0	5,9
LVP 90-50/40-2D	2890	3x230/ 3x400	5,5	10,7
LVP 90-50/40-4D	1410	3x230/ 3x400	3,0	6,44
LVP 100-50/40-2D	2890	3x230/ 3x400	5,5	10,7
LVP 100-50/45-4D	1435	3x230/ 3x400	4,0	8,36

Dimensions and weight

Indication	A	B	C	D	E	F	G	H	I	Mass, kg
LVP 40-20/18-2D	400	200	420	220	440	240	243	358	9	14,5
LVP 50-25/20-2D	500	250	520	270	540	290	293	416	9	18
LVP 50-25/22-2D										19,5
LVP 50-30/22-2D	500	300	520	320	540	340	343	458	9	25,5
LVP 50-30/25-2D										27,7
LVP 60-30/25-2D	600	300	620	320	640	340	343	498	9	31
LVP 60-30/28-2D										37
LVP 60-35/28-2D										39
LVP 60-35/31-2D	600	350	620	370	640	390	393	498	9	39,5
LVP 70-40/31-2DM	700	400	720	420	740	440	443	568	9	47
LVP 70-40/31-2D										51
LVP 70-40/35-2D										52,5
LVP 80-50/35-2D	800	500	820	520	840	540	543	635	9	60,5
LVP 80-50/40-4D										70
LVP 90-50/35-2D	900	500	930	530	960	560	553	650	11	65,5
LVP 90-50/40-4D										75
LVP 90-50/40-2D										78
LVP 100-50/40-2D	1000	500	1030	530	1060	560	553	670	11	85,5
LVP 100-50/45-4D										87

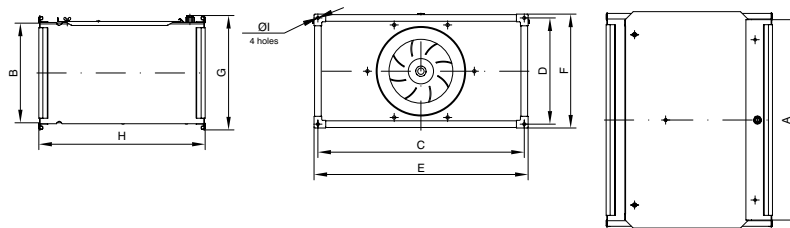
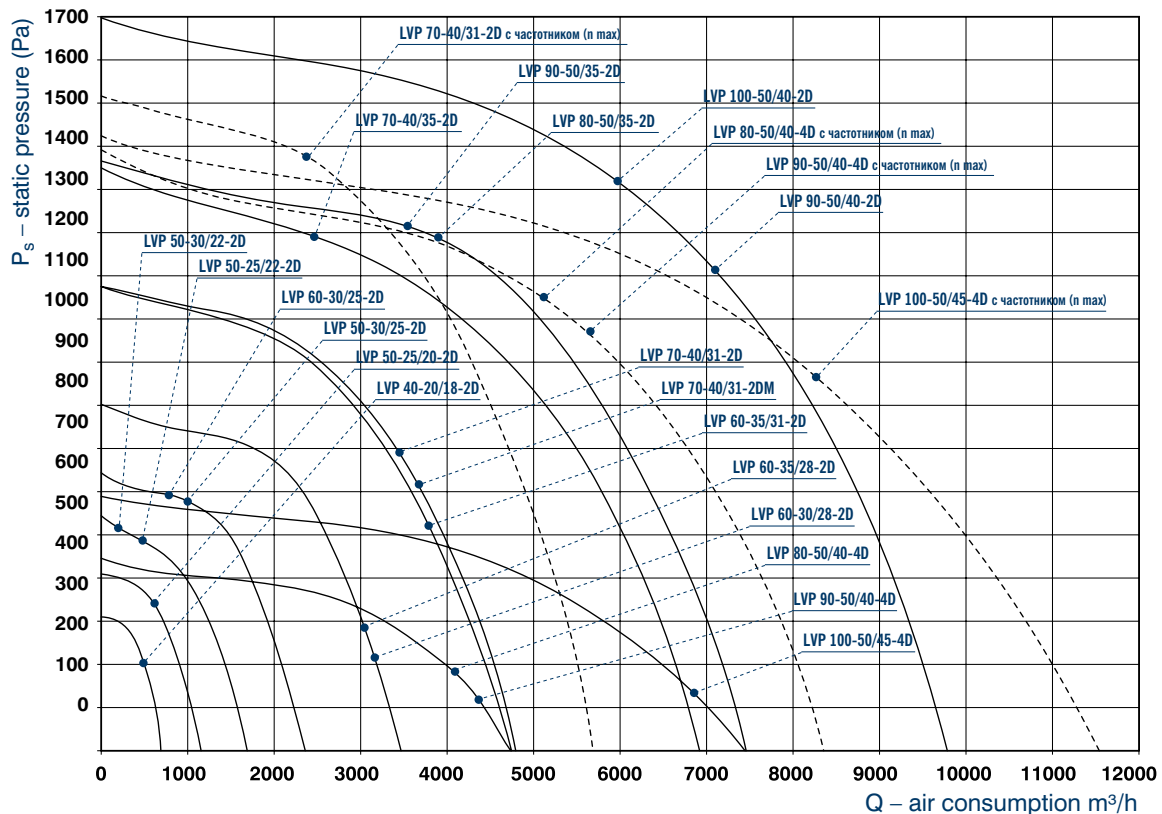
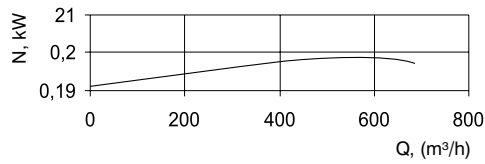
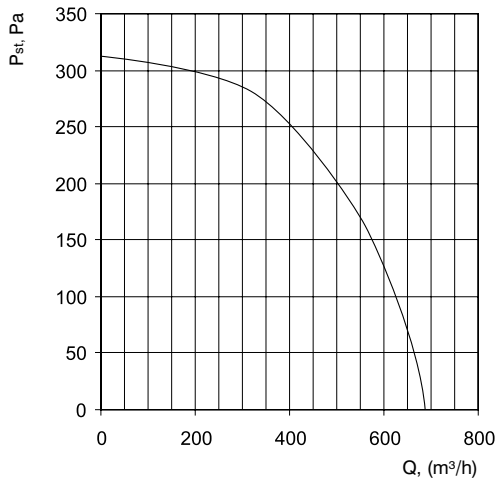

Diagram for quick selection



The following diagrams and tables provide aerodynamic, capacity (electr.) and acoustic specifications of LVP ventilators.

Technical data of ventilator LVP 40-20/18-2D

Acoustic characteristics										
Operation mode Pv, Pa	Sound level LpA, dBA	Summed level, LpS, dB	Sound pressure level (Lp, dB) in octave-frequency band, Hz							
			125	250	500	1000	2000	4000	8000	
Suction noise	260	71,1	73,5	66,5	64,7	68,0	68,0	62,8	56,7	42,3
Discharge noise	260	73,2	75,3	64,5	65,7	70,0	70,0	67,8	59,7	51,3
Noise through casing	260	67,8	70,3	64,2	61,4	64,7	63,2	61,6	53,4	45,7

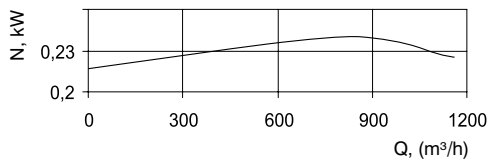
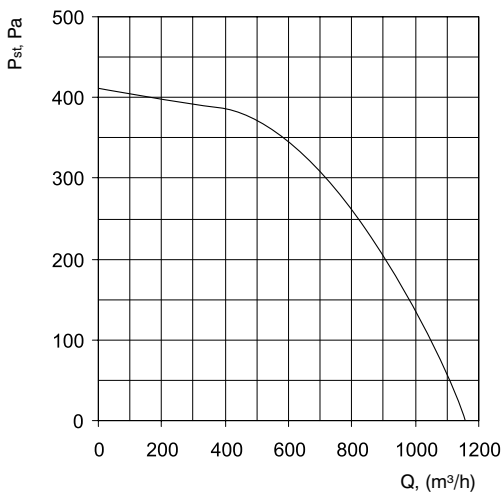
Technical data of ventilator LVP 50-25/20-2D

Acoustic characteristics										
Operation mode Pv, Pa	Sound level LpA, dBA	Summed level, LpS, dB	Sound pressure level (Lp, dB) in octave-frequency band, Hz							
			125	250	500	1000	2000	4000	8000	
Suction noise	310	72,8	75,3	70,4	66,5	66,0	69,5	66,4	60,0	54,1
Discharge noise	310	76,2	80,7	78,1	71,4	70,9	70,9	71,3	62,1	54,1
Noise through casing	310	69,5	78,5	77,8	66,2	64,5	62,7	63,9	54,5	47,3

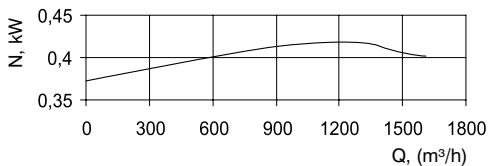
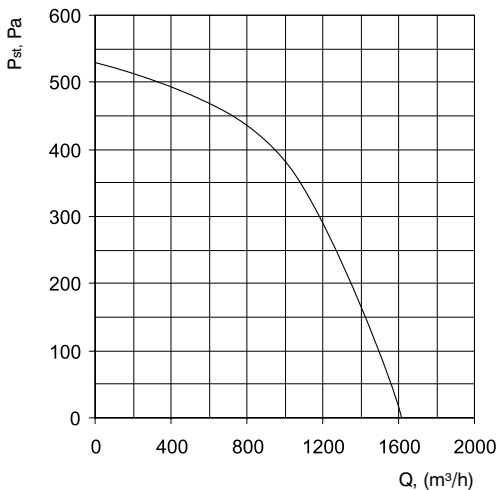
Technical data of ventilator LVP 50-25/22-2D

Acoustic characteristics										
Operation mode Pv, Pa	Sound level LpA, dBA	Summed level, LpS, dB	Sound pressure level (Lp, dB) in octave-frequency band, Hz							
			125	250	500	1000	2000	4000	8000	
Suction noise	400	77,0	77,5	64,8	66,8	69,5	73,5	71,1	65,2	62,6
Discharge noise	400	80,3	81,4	72,5	71,7	74,4	74,9	76,0	67,3	62,6
Noise through casing	400	73,1	76,3	71,4	69,0	68,9	67,0	68,4	59,0	55,4

Technical data of ventilator LVP 50-30/22-2D

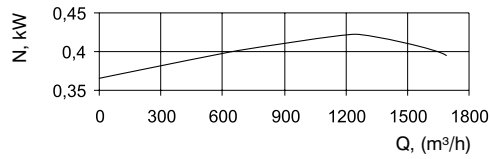
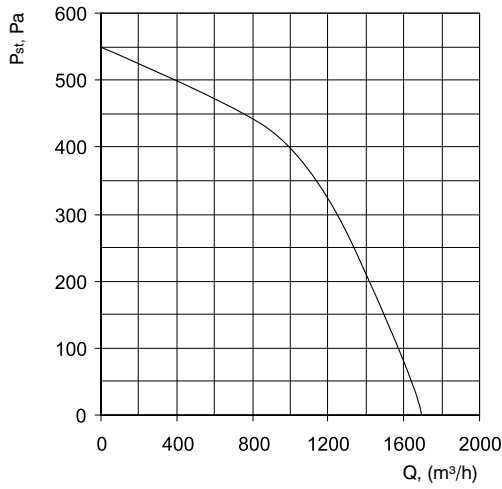

Acoustic characteristics										
Operation mode Pv, Pa	Sound level L _{Pa} , dBA	Summed level, L _{Ps} , dB	Sound pressure level (L _{pi} , dB) in octave-frequency band, Hz							
			125	250	500	1000	2000	4000	8000	
Suction noise	400	78,0	79,2	70,3	68,0	73,7	72,1	73,8	63,4	56,6
Discharge noise	400	81,0	82,6	75,8	71,5	77,2	73,1	77,3	64,9	56,6
Noise through casing	400	74,1	78,2	74,7	68,8	71,7	65,3	69,8	56,6	49,4

Technical data of ventilator LVP 50-30/25-2D

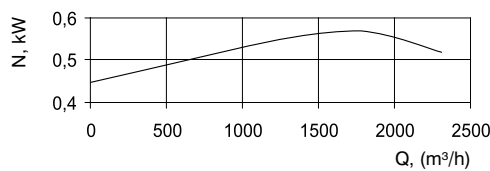
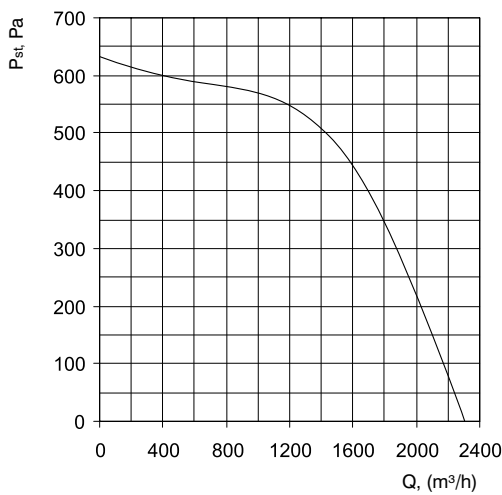

Acoustic characteristics										
Operation mode Pv, Pa	Sound level L _{Pa} , dBA	Summed level, L _{Ps} , dB	Sound pressure level (L _{pi} , dB) in octave-frequency band, Hz							
			125	250	500	1000	2000	4000	8000	
Suction noise	550	79,9	83,7	80,6	72,6	74,0	77,0	73,0	64,4	59,2
Discharge noise	550	81,9	84,6	80,1	73,1	77,5	78,0	76,1	66,4	58,2
Noise through casing	550	74,3	78,7	75,9	68,9	70,0	70,5	67,8	57,7	49,9

Technical data of ventilator LVP 60-30/25-2D

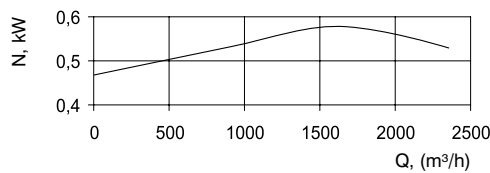
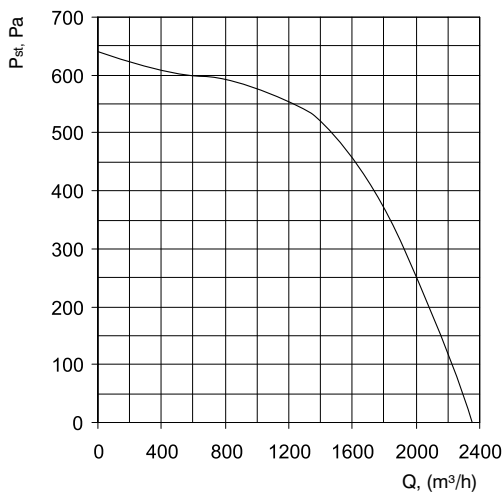

Acoustic characteristics										
Operation mode Pv, Pa	Sound level L _{Pa} , dBA	Summed level, L _{Ps} , dB	Sound pressure level (L _{pi} , dB) in octave-frequency band, Hz							
			125	250	500	1000	2000	4000	8000	
Suction noise	550	82,8	84,4	77,7	73,2	75,7	81,0	74,5	65,4	56,2
Discharge noise	550	84,6	85,8	77,2	73,7	78,9	82,1	77,6	67,4	55,2
Noise through casing	550	75,2	77,6	72,0	68,6	69,7	72,9	67,4	56,7	45,1

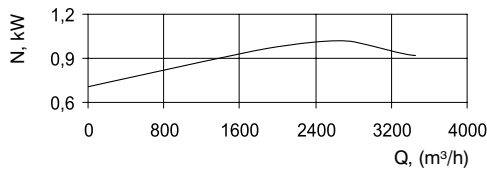
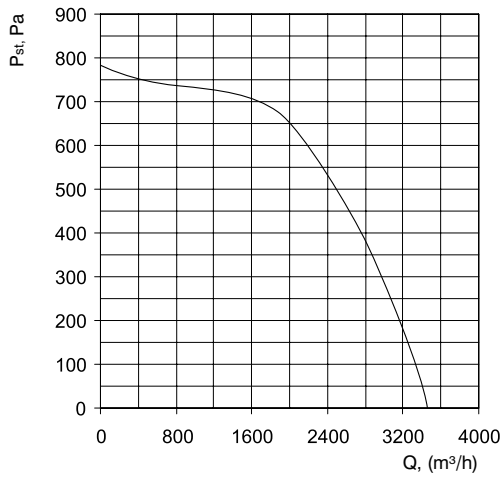
Technical data of ventilator LVP 60-30/28-2D

Acoustic characteristics										
Operation mode Pv, Pa	Sound level L _{Pa} , dBA	Summed level, L _{Ps} , dB	Sound pressure level (L _{pi} , dB) in octave-frequency band, Hz							
			125	250	500	1000	2000	4000	8000	
Suction noise	640	86,4	91,2	88,2	83,1	82,0	83,0	79,0	69,1	66,2
Discharge noise	640	88,3	92,0	87,7	83,6	85,1	84,7	81,0	71,1	65,2
Noise through casing	640	77,5	84,9	83,3	76,6	73,7	73,1	69,6	59,7	54,4

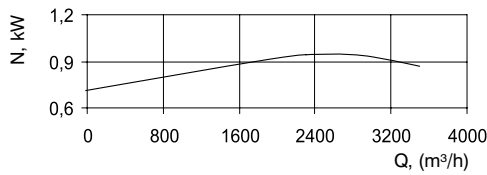
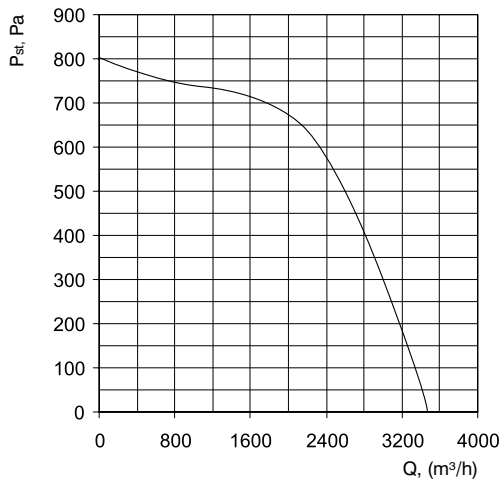
Technical data of ventilator LVP 60-35/28-2D

Acoustic characteristics										
Operation mode Pv, Pa	Sound level L _{Pa} , dBA	Summed level, L _{Ps} , dB	Sound pressure level (L _{pi} , dB) in octave-frequency band, Hz							
			125	250	500	1000	2000	4000	8000	
Suction noise	640	84,5	86,6	81,2	76,5	77,3	82,0	77,0	70,3	69,3
Discharge noise	640	86,3	87,8	80,7	77,0	80,4	83,1	80,1	72,3	68,3
Noise through casing	640	76,6	80,3	76,9	70,9	70,6	73,1	70,3	62,5	59,0

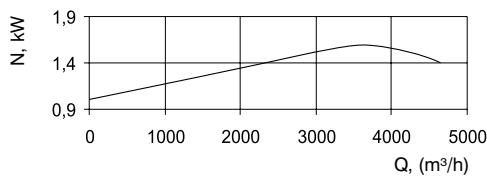
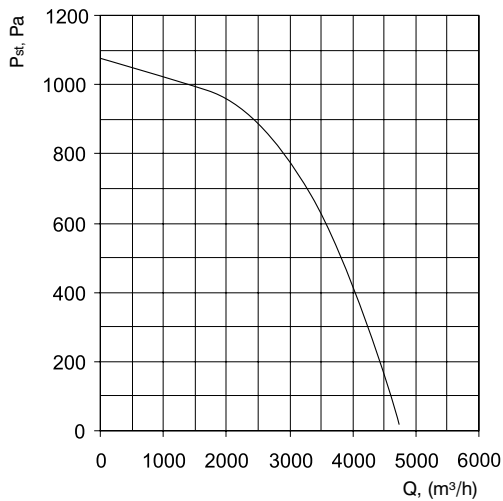
Technical data of ventilator LVP 60-35/31-2D

Acoustic characteristics										
Operation mode Pv, Pa	Sound level L _{Pa} , dBA	Summed level, L _{Ps} , dB	Sound pressure level (L _{pi} , dB) in octave-frequency band, Hz							
			125	250	500	1000	2000	4000	8000	
Suction noise	840	87,4	89,8	76,0	80,1	87,4	82,7	77,7	68,9	64,6
Discharge noise	840	90,2	92,0	83,5	81,6	86,9	87,2	82,7	72,4	66,1
Noise through casing	840	80,0	83,3	79,0	71,0	77,9	76,3	72,0	61,7	55,9

Technical data of ventilator LVP 70-40/31-2DM

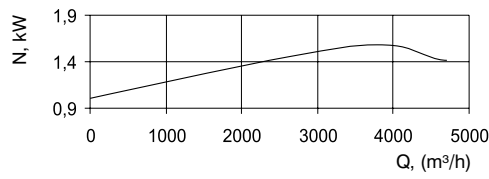
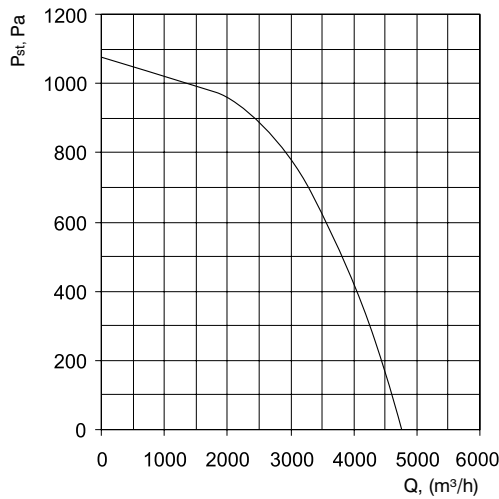

Acoustic characteristics										
Operation mode Pv, Pa	Sound level LPa, dBA	Summed level, LPs, dB	Sound pressure level (Lpi, dB) in octave-frequency band, Hz							
			125	250	500	1000	2000	4000	8000	
Suction noise	840	85,0	87,5	78,6	79,2	83,7	80,2	77,5	68,7	63,6
Discharge noise	840	88,3	90,9	86,1	80,7	83,2	84,7	82,5	72,2	65,1
Noise through casing	840	78,0	83,5	81,6	70,1	74,3	73,8	71,8	61,5	54,9

Technical data of ventilator LVP 70-40/31-2D (ventilator is designed for cooperation with frequency regulator)

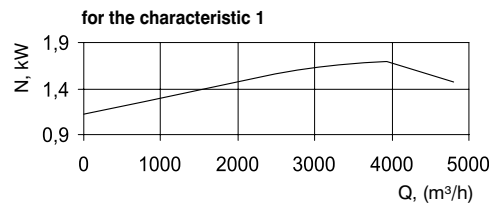
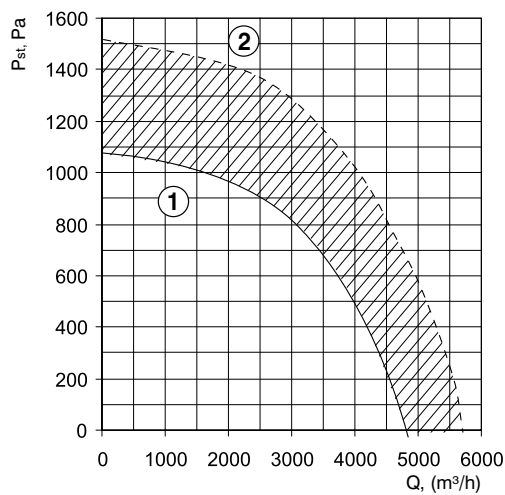

Acoustic characteristics										
Operation mode Pv, Pa	Sound level LPa, dBA	Summed level, LPs, dB	Sound pressure level (Lpi, dB) in octave-frequency band, Hz							
			125	250	500	1000	2000	4000	8000	
Suction noise	840	83,2	85,8	73,5	79,6	81,7	78,6	75,5	66,8	63,4
Discharge noise	840	86,5	88,5	81,0	81,1	81,2	83,1	80,5	70,3	64,9
Noise through casing	840	76,6	80,4	76,7	70,9	72,7	72,7	70,3	60,1	55,2

1 – characteristic on nominal revolutions without frequency regulator (n nom = 2840 min⁻¹)

2 – characteristic on maximum revolutions using frequency regulator (n max = 3420 min⁻¹)

shaded area – area of characteristics using frequency regulator (n nom < n < n max)

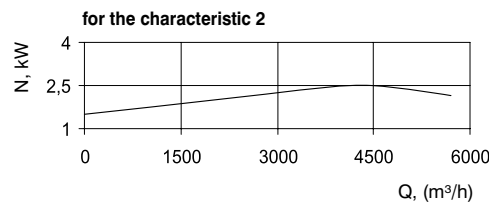

Acoustic characteristics										
Operation mode Pv, Pa	Sound level LPa, dBA	Summed level, LPs, dB	Sound pressure level (Lpi, dB) in octave-frequency band, Hz							
			125	250	500	1000	2000	4000	8000	
Suction noise	1300	87,3	89,8	77,5	83,6	85,8	82,6	79,5	70,8	67,5
Discharge noise	1300	90,6	92,6	85,0	85,1	85,3	87,1	84,5	74,3	69,0
Noise through casing	1300	80,7	84,4	80,8	75,0	76,7	76,7	74,3	64,1	59,3

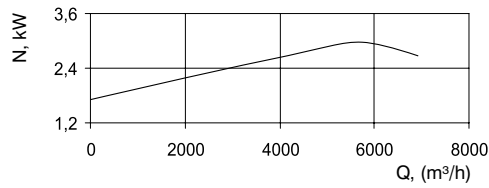
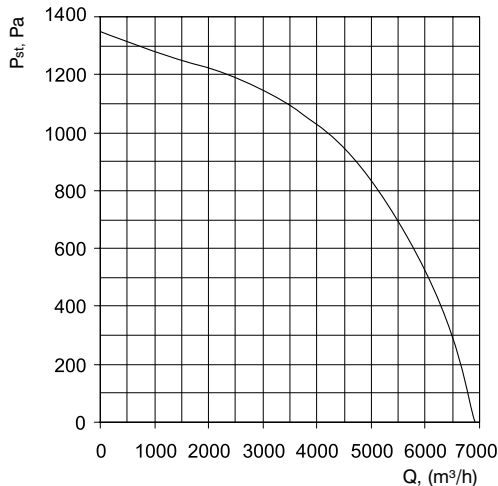
Technical data of ventilator LVP 70-40/35-2D

Acoustic characteristics										
Operation mode Pv, Pa	Sound level L _{Pa} , dBA	Summed level, L _{Ps} , dB	Sound pressure level (L _{pi} , dB) in octave-frequency band, Hz							
			125	250	500	1000	2000	4000	8000	
Suction noise	1145	90,7	92,7	87,0	82,6	85,5	86,9	85,1	74,7	70,2
Discharge noise	1145	87,3	89,6	79,5	81,1	86,0	82,4	80,1	71,2	68,7
Noise through casing	1145	81,0	86,1	83,6	77,1	76,3	77,2	74,3	63,9	61,3

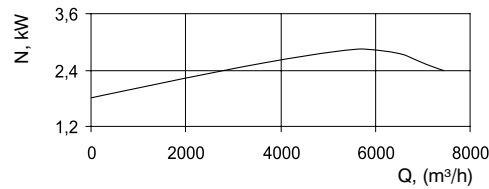
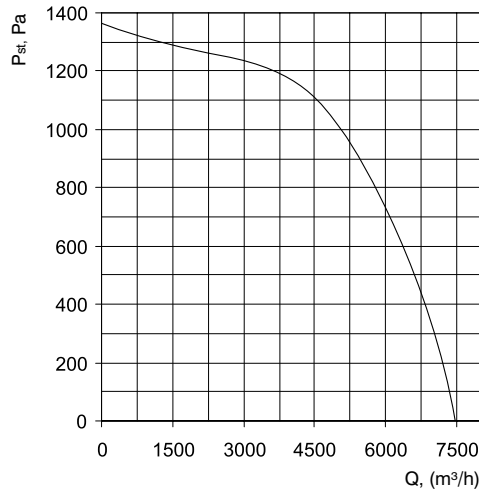
Technical data of ventilator LVP 80-50/35-2D

Acoustic characteristics										
Operation mode Pv, Pa	Sound level L _{Pa} , dBA	Summed level, L _{Ps} , dB	Sound pressure level (L _{pi} , dB) in octave-frequency band, Hz							
			125	250	500	1000	2000	4000	8000	
Suction noise	1145	88,0	90,6	78,6	82,5	87,7	83,0	79,1	69,7	66,7
Discharge noise	1145	90,9	93,1	86,1	84,0	87,2	87,5	84,1	73,2	68,2
Noise through casing	1145	80,5	85,6	82,5	78,0	77,3	77,0	72,3	61,4	58,5

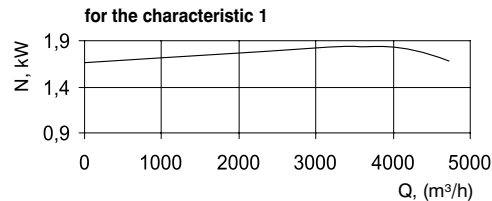
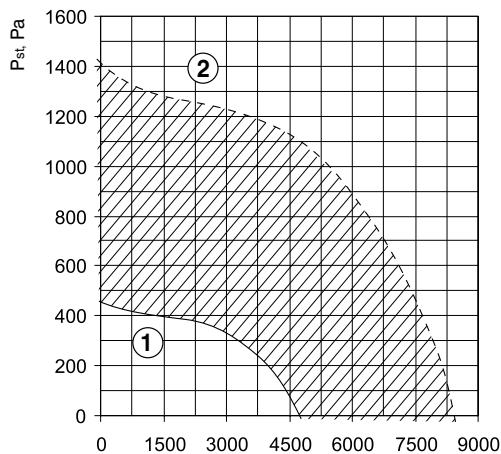
Technical data of ventilator LVP 80-50/40-4D

Acoustic characteristics										
Operation mode Pv, Pa	Sound level L _{Pa} , dBA	Summed level, L _{Ps} , dB	Sound pressure level (L _{pi} , dB) in octave-frequency band, Hz							
			125	250	500	1000	2000	4000	8000	
Suction noise	350	78,7	79,8	69,1	69,6	71,3	77,9	64,2	55,7	50,0
Discharge noise	350	81,6	86,0	82,6	77,7	76,7	79,7	70,5	59,3	55,4
Noise through casing	350	72,1	80,3	79,2	69,3	67,5	69,4	60,1	49,2	45,7

1 – characteristic on nominal revolutions without frequency regulator
(n nom=1410 min⁻¹)

2 – characteristic on maximum revolutions using frequency regulator
(n max=2489 min⁻¹)

shaded area – area of characteristics using frequency regulator
(n nom < n < n max)

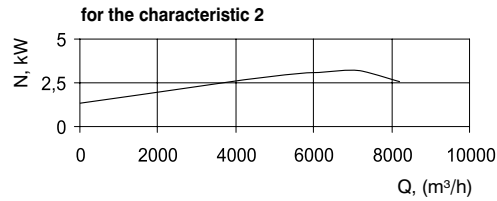

Acoustic characteristics										
Operation mode Pv, Pa	Sound level L _{Pa} , dBA	Summed level, L _{Ps} , dB	Sound pressure level (L _p , dB) in octave-frequency band, Hz							
			125	250	500	1000	2000	4000	8000	
Suction noise	1100	91,0	92,2	81,4	82,0	83,7	90,3	76,5	68,0	62,3
Discharge noise	1100	94,0	98,3	94,9	90,1	89,1	92,1	82,8	71,6	67,7
Noise through casing	1100	84,4	92,6	91,5	81,6	79,8	81,7	72,4	61,5	58,0

Technical data of ventilator LVP 90-50/35-2D

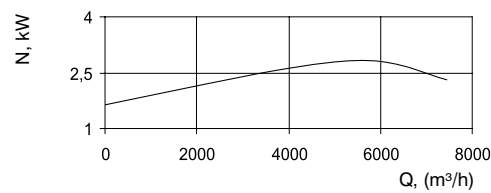
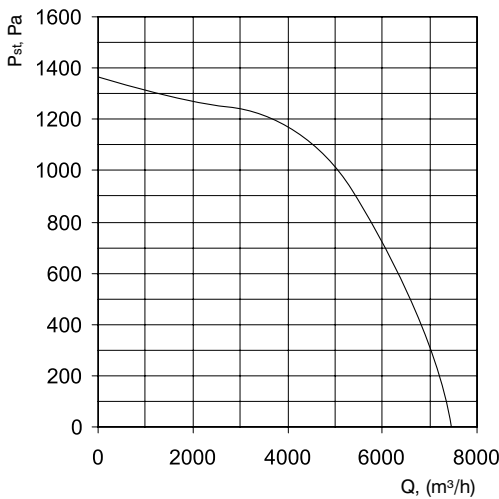

Acoustic characteristics										
Operation mode Pv, Pa	Sound level L _{Pa} , dBA	Summed level, L _{Ps} , dB	Sound pressure level (L _p , dB) in octave-frequency band, Hz							
			125	250	500	1000	2000	4000	8000	
Suction noise	1145	88,4	90,8	80,5	82,5	87,2	84,2	80,1	70,7	66,7
Discharge noise	1145	91,7	93,9	88,0	84,0	86,7	88,7	85,1	74,2	68,2
Noise through casing	1145	81,3	86,8	84,3	78,0	76,8	78,2	73,3	62,4	58,5

Technical data of ventilator LVP 90-50/40-2D

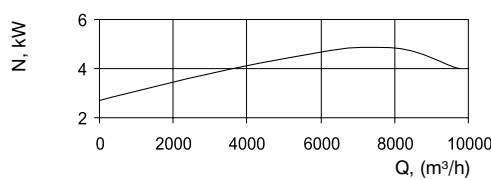
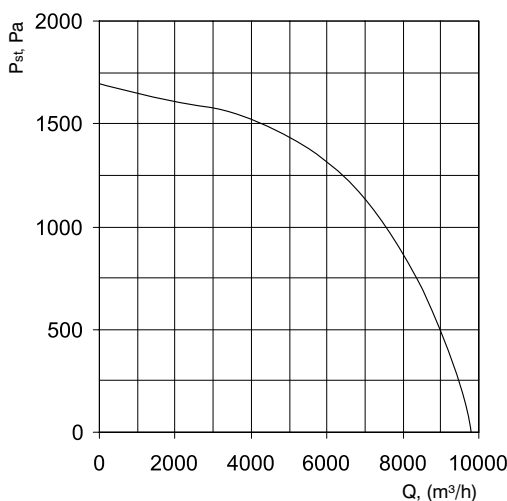

Acoustic characteristics										
Operation mode Pv, Pa	Sound level L _{Pa} , dBA	Summed level, L _{Ps} , dB	Sound pressure level (L _p , dB) in octave-frequency band, Hz							
			125	250	500	1000	2000	4000	8000	
Suction noise	1450	93,5	94,0	79,3	80,7	84,1	92,5	83,5	74,8	66,4
Discharge noise	1450	97,1	99,4	94,3	89,7	90,1	94,5	90,5	78,8	72,4
Noise through casing	1450	88,8	93,7	91,5	82,8	82,5	86,0	81,9	70,5	64,4

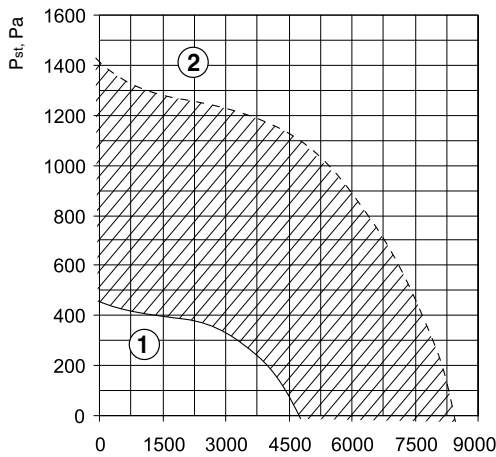
Technical data of ventilator LVP 90-50/40-4D

1 – characteristic on nominal revolutions without frequency regulator ($n_{nom} = 1410 \text{ min}^{-1}$)

2 – characteristic on maximum revolutions using frequency regulator ($n_{max} = 2489 \text{ min}^{-1}$)

shaded area – area of characteristics using frequency regulator ($n_{nom} < n < n_{max}$)

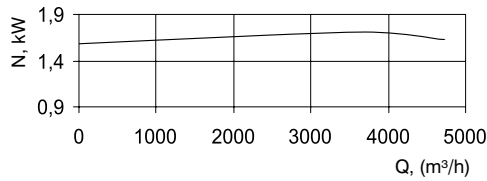
for the characteristic 1

Acoustic characteristics										
Operation mode Pv, Pa	Sound level LPa, dBA	Summed level, LPs, dB	Sound pressure level (Lpi, dB) in octave-frequency band, Hz							
			125	250	500	1000	2000	4000	8000	
Suction noise	350	76,8	77,9	66,6	68,0	68,5	76,1	63,4	56,0	50,7
Discharge noise	350	79,8	83,8	80,1	76,1	73,9	77,9	69,7	59,6	56,1
Noise through casing	350	72,3	79,1	77,5	69,6	66,8	69,9	61,7	51,8	48,6

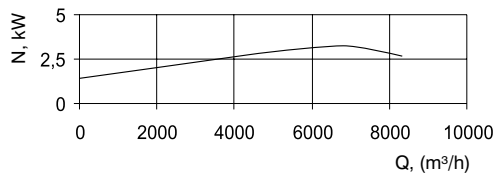
for the characteristic 2

Acoustic characteristics										
Operation mode Pv, Pa	Sound level LPa, dBA	Summed level, LPs, dB	Sound pressure level (Lpi, dB) in octave-frequency band, Hz							
			125	250	500	1000	2000	4000	8000	
Suction noise	1130	89,4	90,4	79,1	80,5	81,0	88,6	75,9	68,5	63,2
Discharge noise	1130	92,3	96,3	92,6	86,6	86,4	90,4	82,2	72,1	68,6
Noise through casing	1130	84,8	91,6	90,0	82,1	79,3	82,4	74,3	64,3	61,1

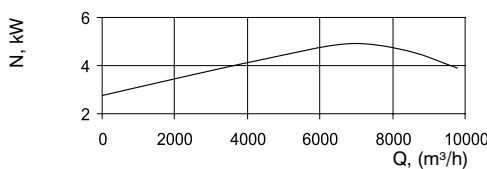
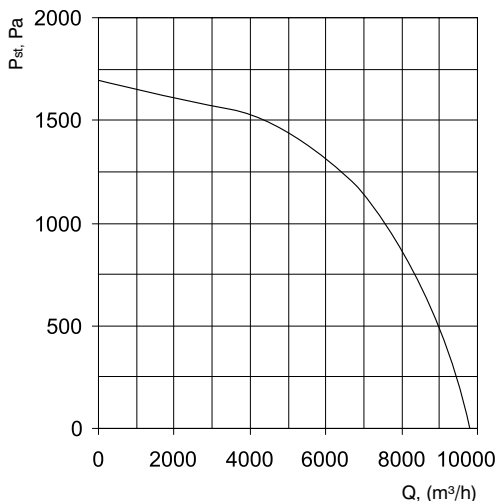
Technical data of ventilator LVP 100-50/40-2D

Acoustic characteristics										
Operation mode Pv, Pa	Sound level LPa, dBA	Summed level, LPs, dB	Sound pressure level (Lpi, dB) in octave-frequency band, Hz							
			125	250	500	1000	2000	4000	8000	
Suction noise	1450	90,9	91,8	78,5	78,4	85,7	89,3	80,9	72,7	66,5
Discharge noise	1450	94,4	97,1	92,0	86,5	91,1	91,1	87,2	76,3	71,9
Noise through casing	1450	86,8	91,8	89,4	80,0	84,0	83,2	79,2	68,5	64,5

Technical data of ventilator LVP 100-50/45-4D

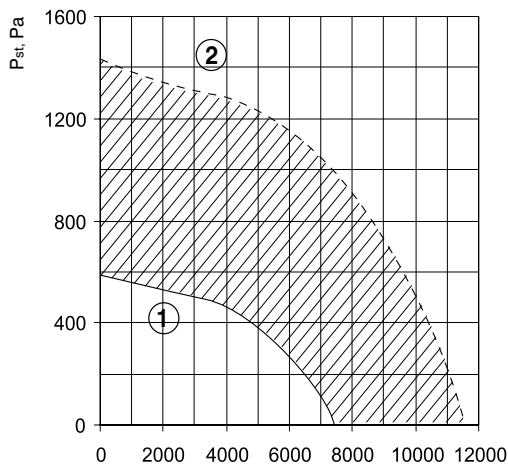

1 – characteristic on nominal revolutions without frequency regulator (n nom = 1435 min⁻¹)

2 – characteristic on the maximum revolutions using frequency regulator (n max = 2229 min⁻¹)

shaded area – area of characteristics using frequency regulator (n nom < n < n max)

for the characteristic 1

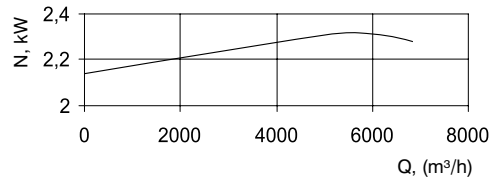

Acoustic characteristics										
Operation mode Pv, Pa	Sound level Lpa, dBA	Summed level, LpA, dB	Sound pressure level (Lpi, dB) in octave-frequency band, Hz							
			125	250	500	1000	2000	4000	8000	
Suction noise	480	83,3	85,8	77,3	79,9	78,2	81,6	71,6	63,4	55,4
Discharge noise	480	86,5	92,1	88,6	86,6	82,7	83,1	76,8	66,4	59,9
Noise through casing	480	75,6	84,3	82,5	78,1	69,9	71,2	65,3	58,1	51,6

for the characteristic 2

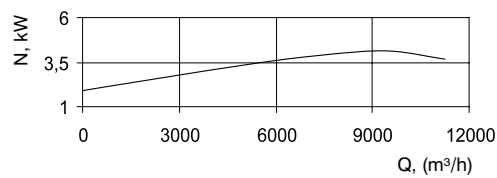

Acoustic characteristics										
Operation mode Pv, Pa	Sound level Lpa, dBA	Summed level, LpA, dB	Sound pressure level (Lpi, dB) in octave-frequency band, Hz							
			125	250	500	1000	2000	4000	8000	
Suction noise	1160	92,6	95,1	86,6	89,1	87,5	90,9	80,9	72,7	64,7
Discharge noise	1160	95,7	101,4	97,8	95,9	92,0	92,4	86,1	75,7	69,2
Noise through casing	1160	84,9	93,6	91,7	87,4	79,2	80,4	74,6	67,4	60,9

ROOF VENTILATORS LVK

General information

Roof ventilators LVK are meant for drawing of air and other nonaggressive nonexplosive gas mixtures. Temperature range of shifting air is between -30°C and $+40^{\circ}\text{C}$ (in some dimension-types up to 70°C).

Ventilators are made in the outdoor design and mounted on roofs so that the rotation axis of the motor is positioned vertically.

Ventilators have a vertical air emission.

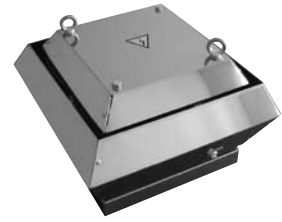

Construction and materials

LVK ventilators are fitted with asynchronous 1-phase or 3-phase motor with outer rotor and backward-curved blades.

All the electric motors have an overheating protection provided by the heat contact inside the winding. The heat contacts outlets should be connected up to the external motor protection device.

Ventilator case and impeller are made of steel galvanized sheet.

The electric motor case has a class IP 54 insulation. Winding is extra protected from moisture.

Applied materials and technologies allow to achieve more than 50 000 hours of the ventilator endurance without additional service.

Capacity control

Capacity control of the LVK ventilators is implemented by changing the supplied voltage (transformer, phase, tiristor regulators) or frequency (frequency regulators).

Indication

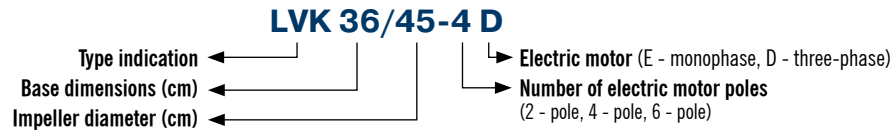

Dimension-types

Indication	Dimensions, mm						Mass, kg
	A	B	C	D	E	F	
LVK 30/22-2E	300	385	160	7	30	245	6,4
LVK 40/31-4D	400	580	298	12	40	330	15,0
LVK 40/32-4D	400	580	298	12	40	330	17,4
LVK 56/35-4E	560	780	358	12	40	450	29,6
LVK 56/35-4D	560	780	358	12	40	450	30,4
LVK 56/40-4E	560	780	358	12	40	450	29,8
LVK 56/40-4D	560	780	358	12	40	450	30,8
LVK 63/45-4E	630	870	393	12	40	535	40,5
LVK 63/45-4D	630	870	393	12	40	535	40
LVK 63/50-6D	630	870	393	12	40	535	40,7
LVK 63/50-4D	630	870	393	12	40	535	48,4
LVK 90/56-6D	900	1250	578	12	40	750	70
LVK 90/56-4D	900	1250	578	12	40	750	77
LVK 90/63-6D	900	1250	578	12	40	750	78

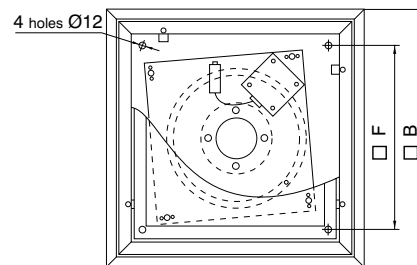
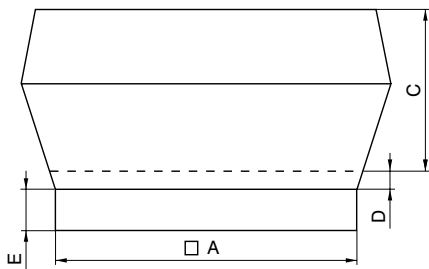

Basic technical information

Ventilator indication	Max. air consumption, m ³ /h	Max. full pressure, Pa	Revolutions at max. efficiency factor, min ⁻¹	El. motor voltage, V	Max. capacity, kW	Max. current, A	Sound level at max. efficiency factor, dB	Max. permissible temperature, C°
LVK 30/22-2E	1050	470	2730	220	0,17	0,71	79	50 °C
LVK 40/31-4D	1570	240	1360	380	0,11	0,23	65	70 °C
LVK 40/32-4D	1900	270	1390	380	0,14	0,35	64	70 °C
LVK 56/35-4D	2950	320	1330	380	0,25	0,47	68	60 °C
LVK 56/35-4E	2900	340	1360	220	0,31	1,45	69	65 °C
LVK 56/40-4D	4050	400	1340	380	0,45	0,86	70	55 °C
LVK 56/40-4E	4050	395	1350	220	0,49	2,2	71	40 °C
LVK 63/45-4E	5300	460	1230	220	0,73	3,3	74	60 °C
LVK 63/45-4D	5600	450	1220	380	0,69	1,3	74	40 °C
LVK 63/50-4D	7800	600	1340	380	1,15	2,1	78	45 °C
LVK 63/50-6D	5200	250	850	380	0,39	0,81	67	45 °C
LVK 90/56-4D	10100	700	1230	380	1,8	3,4	79	40 °C
LVK 90/56-6D	7100	310	830	380	0,61	1,05	69	40 °C
LVK 90/63-6D	10150	430	870	380	1,05	2,2	77	70 °C

Aerodynamic characteristics

The diagram provides external aerodynamic curves of the roof ventilators

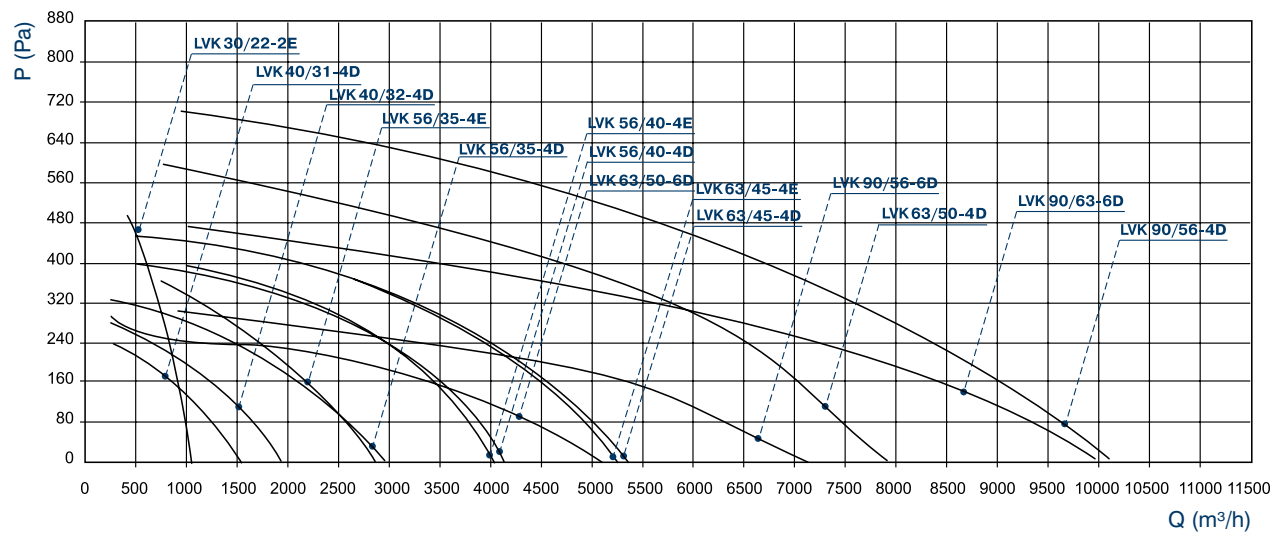

WATER AIR-HEATERS FOR ROUND CHANNELS WKK

General information

Water air-heaters WKK are designed for air heating in round air channels. The shifting air must not contain aggressive admixtures. Maximal water temperature must not exceed 170°C and maximal pressure of 1,5 MPa. Anti-freeze mixtures can also be used as a heat carrier in WKK heaters. WKK air-heaters can function in any position providing air discharge from water contour.

Construction and materials

Heaters are made in a two-row design. Heat-exchange surface consists of aluminium plates and passing-through brass tubes of 9,52 mm in diameter. Casing of the heaters is made of a steel galvanized sheet. All heaters are checked for impermeability at 20 Atm pressure for 10 min.

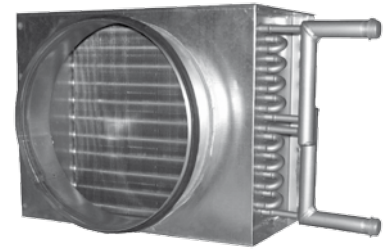

Dimension-types

Dimension type	Dimensions				Mass, kg
	A	B	C	D	
WKK 160	270	160	261	375	3,6
WKK 200	295	200	286	400	4,0
WKK 250	345	250	336	450	4,94
WKK 315	420	315	411	525	5,1

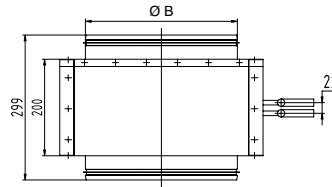
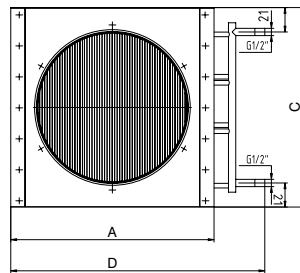

Basic technical data

Dimension type	Air consumption, m ³ /h	Water consumption, m ³ /h	Hydraulic resistance, kPa	Heating efficiency, kW	Output air temperature, °C
WKK 160/2	350	0,3	2,8	6,93	20
WKK 200/2	530	0,44	6,17	10	18
WKK 250/2	850	0,7	18,29	16	18
WKK 315/2	1330	1,11	21,1	25,17	18

Outside air temperature $T_{outside} = -28^{\circ}C$
 Water temperature: 90/70° C

Aerodynamic characteristics

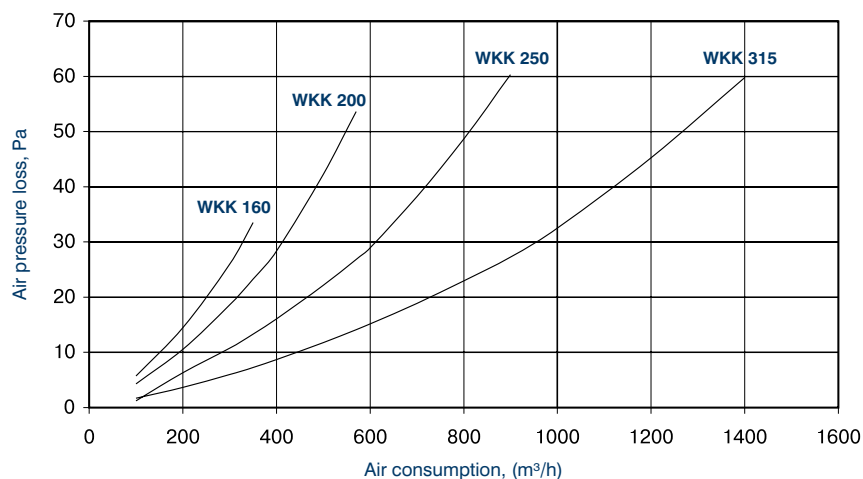

WATER AIR-HEATERS FOR RECTANGULAR CHANNELS WKN

General information

Water air-heaters type WKN are meant for air heating in channel rectangular ventilation systems. The shifting air must not contain aggressive admixtures.

Maximum water temperature – 170° C.

Maximum water pressure – 1,5 MPa.

Heat exchanger is made of copper pipes 9,52 mm in diameter with aluminium ribbing. Pipes are staggered. The case of the heat exchanger is made of steel galvanized sheet. Radiators are produced in a two-row and three-row design.

Water air-heaters WKN can function in any position providing air discharge from the heater.

Anti-freeze mixtures can be used as a heat carrier.

Each radiator is checked for impermeability by molding at 20 Atm pressure for 10 min.



Indication

WKN 40-20/2

- ▶ Two-row design of a heater
- ▶ Fitting dimensions (cm)
- ▶ Type indication of water air-heater

Dimensions and weight

Indication	Dimensions, mm							Mass, kg
	A	D	C	D	E	F	G	
Two-row								
WKN 40-20/2	400	200	420	220	440	240	9	5.6
WKN 50-25/2	500	250	520	270	540	290	9	6.6
WKN 50-30/2	500	300	520	320	540	340	9	7.1
WKN 60-30/2	600	300	620	320	640	340	9	8.1
WKN 60-35/2	600	350	620	370	640	390	9	8.8
WKN 70-40/2	700	400	720	420	740	440	9	10.6
WKN 80-50/2	800	500	820	520	840	540	9	13.5
WKN 90-50/2	900	500	930	530	960	560	13	16.4
WKN 100-50/2	1000	500	1030	530	1060	560	13	19.4
Three-row								
WKN 40-20/3	400	200	420	220	440	240	9	7.1
WKN 50-25/3	500	250	520	270	540	290	9	8.6
WKN 50-30/3	500	300	520	320	540	340	9	10.1
WKN 60-30/3	600	300	620	320	640	340	9	11.6
WKN 60-35/3	600	350	620	370	640	390	9	13.1
WKN 70-40/3	700	400	720	420	740	440	9	14.6
WKN 80-50/3	800	500	820	520	840	540	9	16.1
WKN 90-50/3	900	500	930	530	960	560	13	17.6
WKN 100-50/3	1000	500	1030	530	1060	560	13	21.1

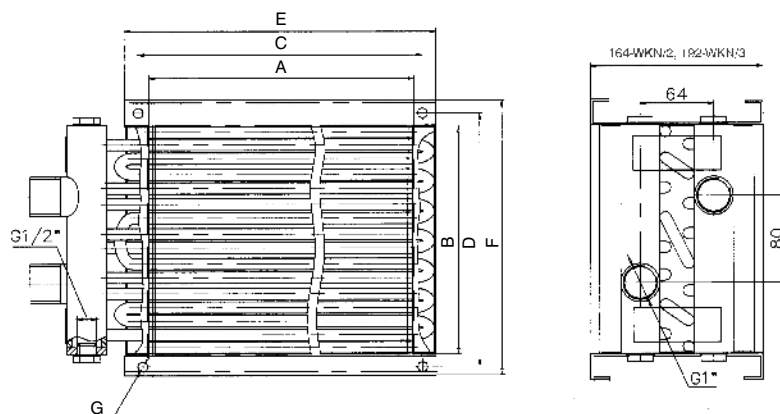

Characteristics of two-row water heaters

Aerodynamic characteristics of heaters WKN /2

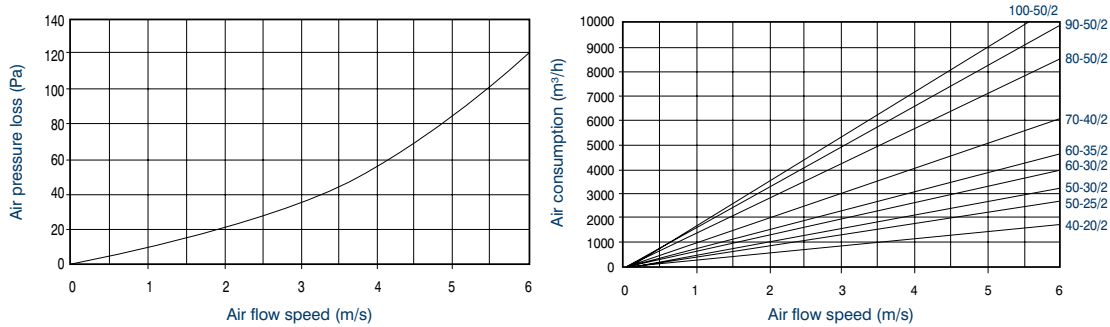

Hydraulic characteristics of heaters WKN /2

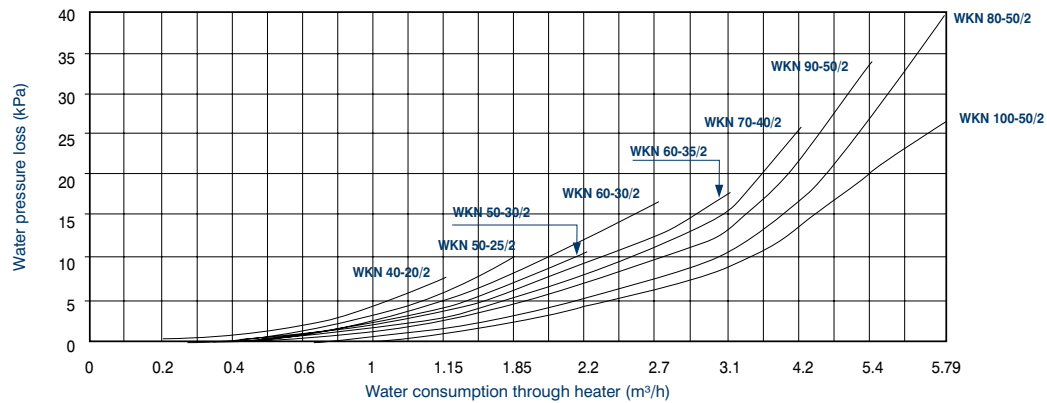

Thermotechnical characteristics of heaters WKN /2

Dimension type	Air consumption, m³/h	Water consumption, m³/h	Heating efficiency, kW	Output air, C
40-20	1150	0,81	18,57	18
50-25	1800	1,27	29,06	18
50-30	2150	1,51	34,71	18
60-30	2600	1,83	41,97	18
60-35	3020	2,13	48,75	18
70-40	4030	2,84	65,06	18
80-50	5750	4,05	92,83	18
90-50	6480	4,57	104,61	18
100-50	7200	5,07	116,25	18

Outside air temperature $T_H = -30^\circ\text{C}$
 Water temperature: $90^\circ/70^\circ\text{C}$

The table provides information about individual function modes of radiators. Selection of air-heaters for particular conditions is made with a special computer program "EVR".

Characteristics of three-row water heaters

Aerodynamic characteristics of heaters WKN /3

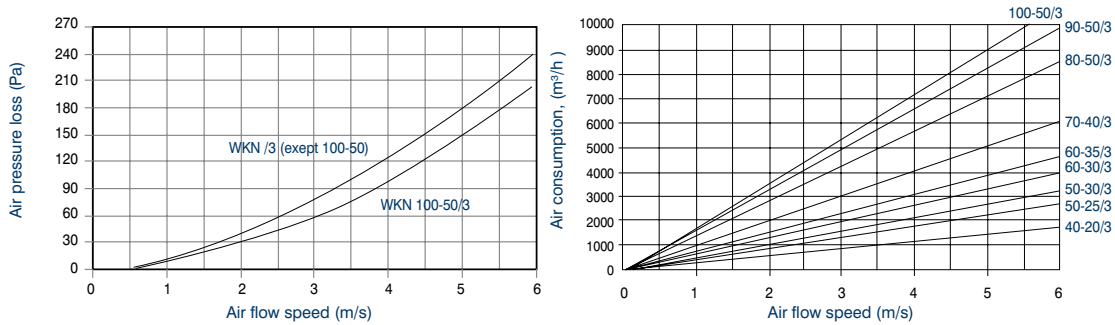

Hydraulic characteristics of heaters WKN /3

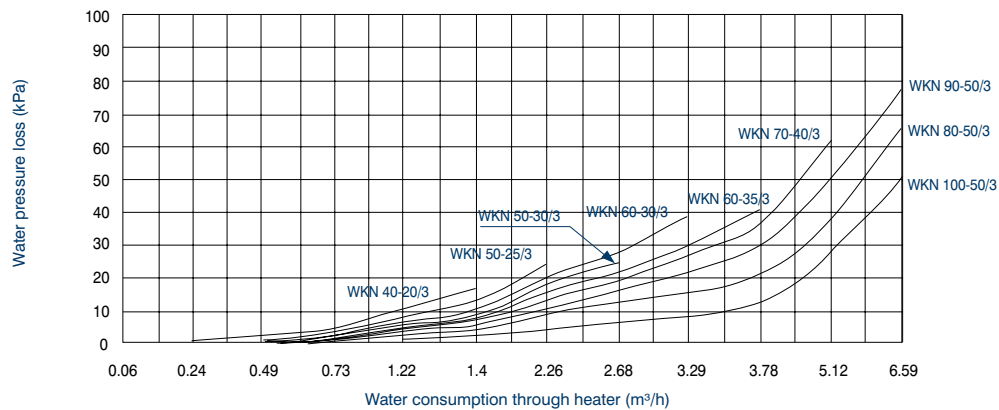

Thermotechnical characteristics of heaters WKN /3

Dimension type	Air consumption, m ³ /h	Water consumption, m ³ /h	Heating efficiency, kW	Output air, C
40-20	1150	1,16	26,69	29
50-25	1800	1,82	41,77	29
50-30	2150	2,18	49,90	29
60-30	2600	2,63	60,34	29
60-35	3020	3,06	70,09	29
70-40	4030	4,08	93,52	29
80-50	5750	5,82	133,44	29
90-50	6480	6,56	150,38	29
100-50	7200	7,29	167,09	29

Outside air temperature $T_H = -40^\circ\text{C}$
 Water temperature: $90^\circ/70^\circ\text{C}$

The table provides information about individual function modes of radiators. Selection of air-heaters for particular conditions is made with a special computer program "EVR".

MIXING UNITS SRP

General information

Mixing units of SRP type are designed for the regulation of heat power of an air-heater by changing of air-heater temperature delivered to the radiator. In this case water discharge through the heat exchanger remains permanent.

Mixing units consist of: circulation pump with "wet" rotor, three-way valve ESBE (type 3 MG) with analogous drive ESBE 62P, shutoff ball plug valves, heating water filter, bypass with the backward and regulation valve, flexible conjunctive pipes made of stainless steel.



Working conditions

Heat carrier must not contain solid impurities and aggressive chemical substances promoting corrosion and decomposition of materials of the mixing unit.

Maximum water temperature – 110° C.

Maximum water pressure – 1 MPa.

Minimal working pressure 20 kPa.

Working temperature of water shall not be lower than temperature of the surrounding air in order to prevent condensation in the motor winding.

Indication for mixing units

SRP 40-2,5

- Kv of the valve (1/1,6/2,5/4/6,3/8/12/18)
- Circ. pump (40 – UPS25-40; 60 – UPS25-60; 80 – UPS25-80 or UPS32-80)
- Type and design

Dimension-types and design

Mixing unit	Pump	3-way valve	A	B	C	Weight
Tips SRP	Tips Grundfos	Tips ESBE	mm	mm	mm	kg
SRP 40-1,0	UPS 25:40	3MG 15:1,0	880	250	G1"	8,5
SRP 40-1,6	UPS 25:40	3MG 15:1,6	880	250	G1"	8,5
SRP 40-2,5	UPS 25:40	3MG 15:2,5	880	250	G1"	8,5
SRP 40-4,0	UPS 25:40	3MG 20:4,0	880	250	G1"	8,4
SRP 60-4,0	UPS 25:60	3MG 20:4,0	880	250	G1"	8,4
SRP 60-6,3	UPS 25:60	3MG 20:6,3	880	250	G1"	8,5
SRP 80-6,3	UPS 25:80	3MG 20:6,3	880	250	G1"	8,5
SRP 80-8,0	UPS 25:80	3MG 25:8,0	880	250	G1"	10,3
SRP 80-12,0	UPS 32:80	3MG 25:12,0	910	280	G1 1/4"	13,25
SRP 80-18,0	UPS 32:80	3MG 32:18,0	910	280	G1 1/4"	13,25

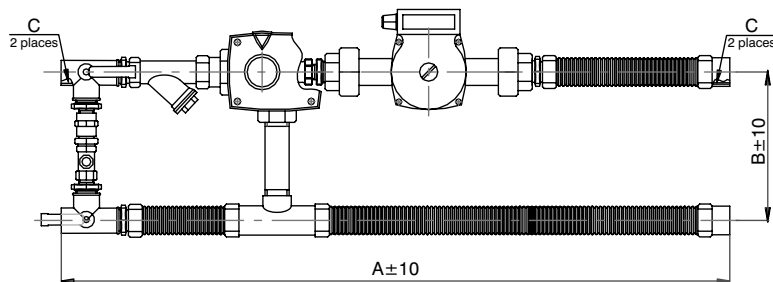

Power control

Power control is implemented by a pump which provides permanent water circulation in the heater and a three-way valve with servo-motor, providing mixing of water coming from the boiler, and water leaving the air-heater.

The pump serves only for overcoming of pressure loss in the air-heater and in the components of the mixing unit itself.

In case full power of air-heater is needed, all the water flows in a big circuit – from the boiler in “a” direction through the air-heater back to the heating water collector.

In case full power is not needed, the three-way valve starts to leak some water in “b” direction gradually lowering the temperature of the water flowing through the air-heater. At zero heating power all the water flows only in the air-heater circuit, i.e. valve leaks water only in “b” direction. To avoid full stop of water flow in the boiler circuit mixing unit is equipped with a bypass. The surplus of heating water is brought back to the water collector through the bypass.

The bypass is equipped with a backward valve and a regulation valve which serves for optimal pressure loss on the bypass. The bypass also prevents water cooling in the boiler contour before heater.

Mixing unit should be installed at a minimal distance from a heater. When installing the unit the pump shaft should be positioned horizontally.

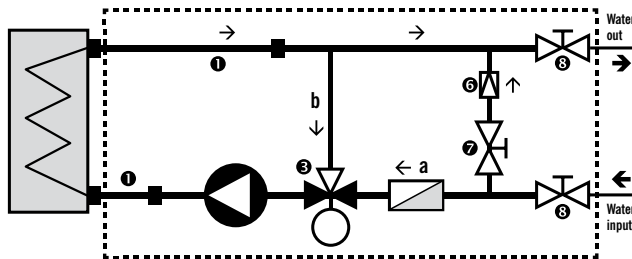

Components of the mixing unit

1. Non-corrosive conjunctive hose
2. Circulation pump Grundfos
3. Three-way valve ESBE
4. Valve servo-motor
5. Sediment and cleaning filter
6. Back valve
7. Regulation valve for bypass resistance installation
8. Service shutoff ball plug valves

Technical characteristics

Tech. and el. parameters	UPS 25-...			UPS 32-80
	...40	...60	...60	
Power supply (V)	1x230AC			
El. Protection (IP)	42			
Capacity, max (W)	75	100	245	245
Current, max (A)	0,31	0,43	1,04	1,05

Tech. and el. parameters	ESBE 62P
Power supply (V)	24
El. Protection (IP)	41
Capacity, max (W)	1.3/3
Angle (degree)	90
Moment (Nm)	5
Slew time (s)	120
Control (V)	0...10

Characteristics for unit calculation

Main condition for smooth regulation of the air-heater is a correct calculation of the mixing unit. Further on the executive schedules of the units are provided. Each schedule consists of three characteristics – water consumption (q_{wsrp}), pressure (Δp_{wsrp}) of the unit at particular pump revolutions, drop of pressure on a 3-way valve (Δp_{w3cv}). The blue stripe indicates working area where the unit can be exploited. For the determined consumption and pressure of the air-heater the unit is selected so that the drop of pressure on the 3-way valve is higher than the total pressure on the water air-heater, i.e. $\Delta p_{w3cv} > \Delta p_{wsrp}$.

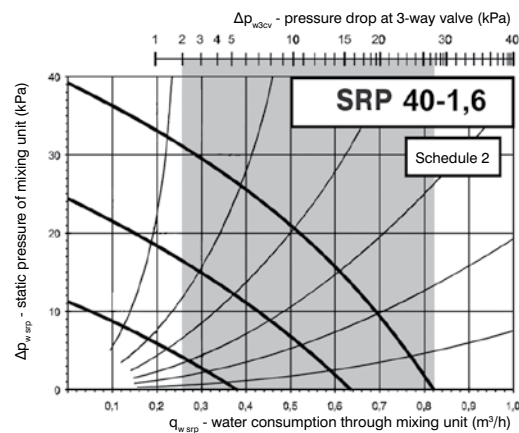
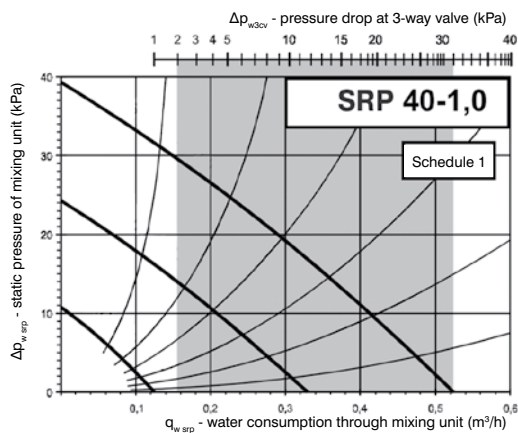

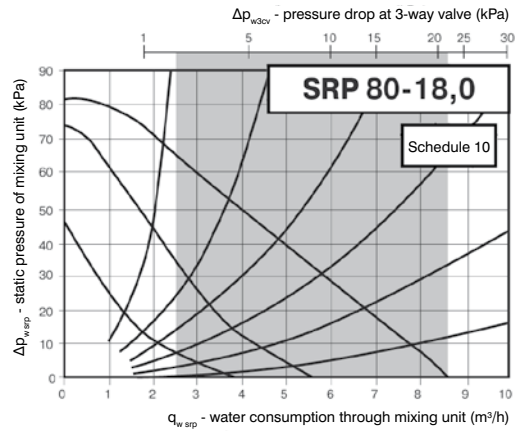
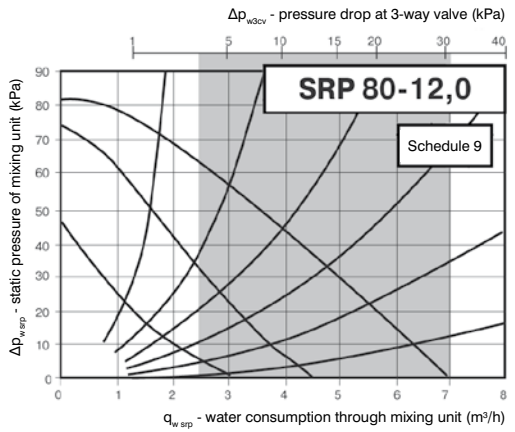
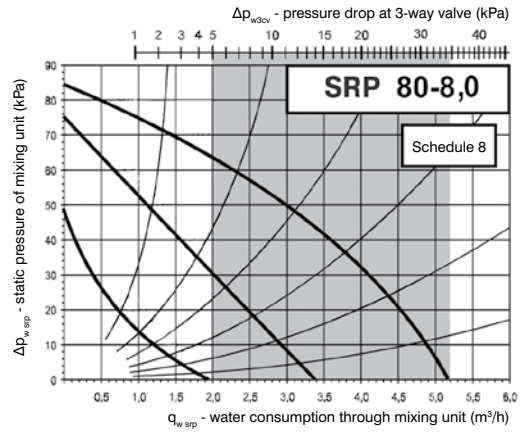
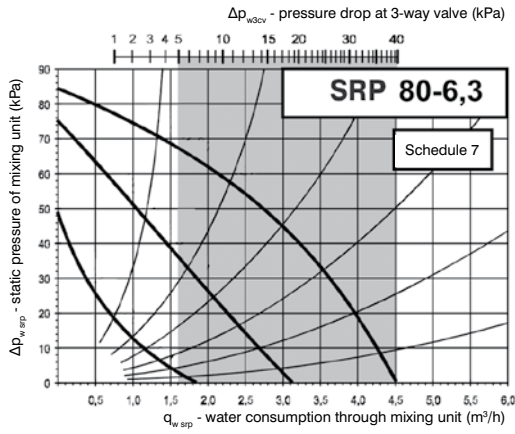
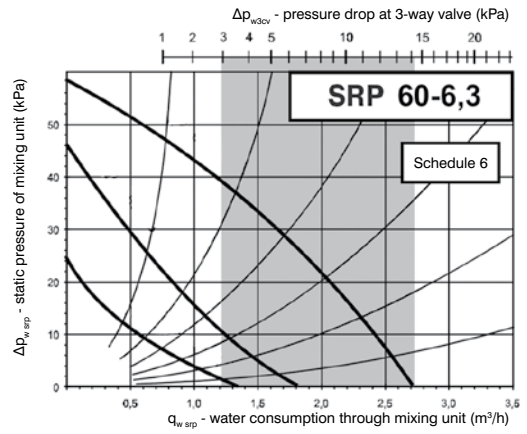
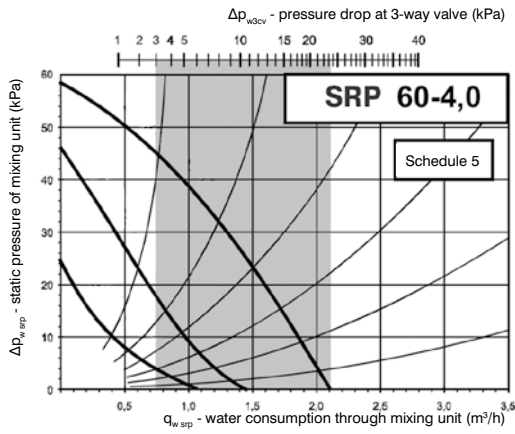
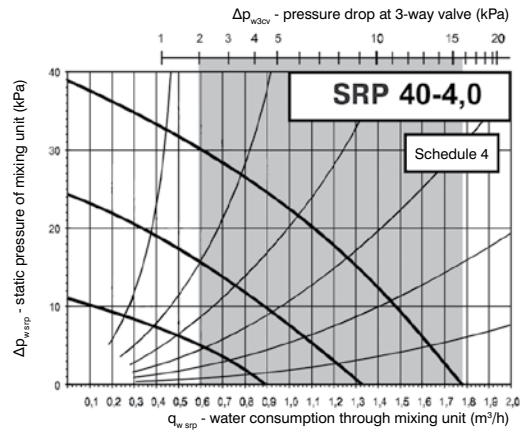
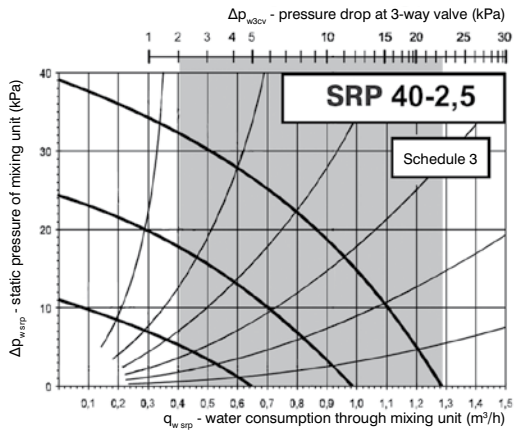

ELECTRIC AIR-HEATERS FOR ROUND CHANNELS EKK

General information

Electric air-heaters EKK are designed for air heating in round air channels. The shifting air must not contain aggressive admixtures. Operating temperature range - from -40 up to +40° C.

Construction and materials

Heater casing, as well as electrical board are made from a galvanized steel sheet. Tubular electrical elements are used for heating. Protection class IP 40.

Hot-air radiators of 12 kW power and more are executed with two equal power levels.



Dimension-types

Indication	Dimensions в mm					Mass, kg			
	A	B	C	D	E				
EKK 100/0,5	271	370	104	74	100	2,63			
EKK 100/1,5						2,89			
EKK 100/2	346	444	104	74	100	3,51			
EKK 100/2,5						3,64			
EKK 125/1,5	271	370	129	82	125	3,43			
EKK 125/2						3,54			
EKK 125/2,5						3,67			
EKK 125/3						3,71			
EKK 160/2	271	400	164	83	160	4,32			
EKK 160/3						4,40			
EKK 160/4,5						4,68			
EKK 160/6	391	490	204	86	200	6,43			
EKK 200/3	271	370				204	86	200	5,27
EKK 200/6									6,03
EKK 200/9	391	490				8,72			
EKK 200/12	271	370	254	99	250	7,31			
EKK 250/6						8,09			
EKK 250/9						10,33			
EKK 250/12						10,57			
EKK 250/15	391	490	319	98	315	8,86			
EKK 315/6	271	370				319	98	315	9,64
EKK 315/9									12,25
EKK 315/12	391	490				319	98	315	12,49
EKK 315/15			13,81						
EKK 315/18									

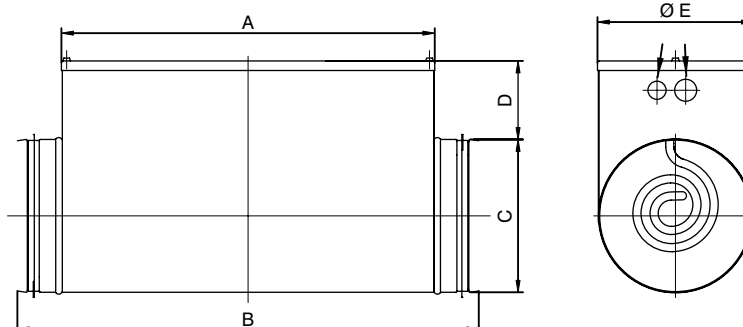

Technical characteristics

N ^o	Dimension type	Power, kW	Input current, A	Voltage, V	Feeder cable	Feeder cables, q-ty	Protective circuit
1	EKK 100/0,5	0,5	2,27	1~220	BBГ 3x1.5	1	ПВС 2x0.75
	EKK 100/1.5	1,5	6,8	1~220	BBГ 3x1.5		
	EKK 100/2	2	9,1	1~220	BBГ 3x2.5		
	EKK 100/2,5	2,5	11,3	1~220	BBГ 3x2.5		
2	EKK 125/1.5	1,5	6,8	1~220	BBГ 3x1.5	1	ПВС 2x0.75
	EKK 125/2	2	9,1	1~220	BBГ 3x2.5		
	EKK 125/2,5	2,5	11,3	1~220	BBГ 3x2.5		
	EKK 125/3	3	13,6	1~220	BBГ 3x2.5		
3	EKK 160/2	2	9,1	1~220	BBГ 3x2.5	1	ПВС 2x0.75
	EKK 160/3	3	13,6	1~220	BBГ 3x2.5		
	EKK 160/4,5	4,5	6,8	3~380	BBГ 4x2.5		
	EKK 160/6	6	9,1	3~380	BBГ 4x2.5		
4	EKK 200/3	3	13,6	1~220	BBГ 3x2.5	1	ПВС 2x0.75
	EKK 200/6	6	9,1	3~380	BBГ 4x2.5		
	EKK 200/9	9	13,6	3~380	BBГ 4x2.5		
	EKK 200/12	12	18,1	3~380	BBГ 4x2.5	2	
5	EKK 250/6	6	9,1	3~380	BBГ 4x2.5	1	ПВС 2x0.75
	EKK 250/9	9	13,6	3~380	BBГ 4x2.5		
	EKK 250/12	12	19,1	3~380	BBГ 4x2.5	2	
	EKK 250/15	15	22,7	3~380	BBГ 4x2.5		
6	EKK 315/6	6	9,1	3~380	BBГ 4x2.5	1	ПВС 2x0.75
	EKK 315/9	9	13,6	3~380	BBГ 4x2.5		
	EKK 315/12	12	18,1	3~380	BBГ 4x2.5	2	
	EKK 315/15	15	22,7	3~380	BBГ 4x2.5		
	EKK 315/18	18	27,2	3~380	BBГ 4x2.5		

Power control

All heaters of EKK type are equipped with thermostats for temperature limitation and circuit of thermostats that breaks in case of overheating.

The power of electrical heaters should be adjusted automatically, but the outlet temperature beyond a heater should be limited to 40° C, therefore it is recommended to equip EKK type heaters with a control unit PUA to provide automatical power control and temperature required.

In case ventilation system is switched off manually, it is necessary to switch off a heater first, then after the heater cools down switch on ventilator and close air chokes.

The drop of air flow speed in the heaters is not allowed below 1-2 m/s, therefore in case inlet ventilator stoppage or air flow speed drop below the critical value the electrical heaters' operation should be stopped.

Aerodynamic characteristics

EKK 100/0,5	I	EKK 200/6	II
EKK 100/1,5	I	EKK 200/9	II
EKK 100/2	II	EKK 200/12	III
EKK 100/2,5	II	EKK 250/6	I
EKK 125/1,5	I	EKK 250/9	I
EKK 125/2	I	EKK 250/12	II
EKK 125/2,5	III	EKK 250/15	I
EKK 125/3	III	EKK 315/6	I
EKK 160/2	II	EKK 315/9	I
EKK 160/3	II	EKK 315/12	II
EKK 160/4,5	II	EKK 315/15	I
EKK 160/6	II	EKK 315/18	I
EKK 200/3	II		

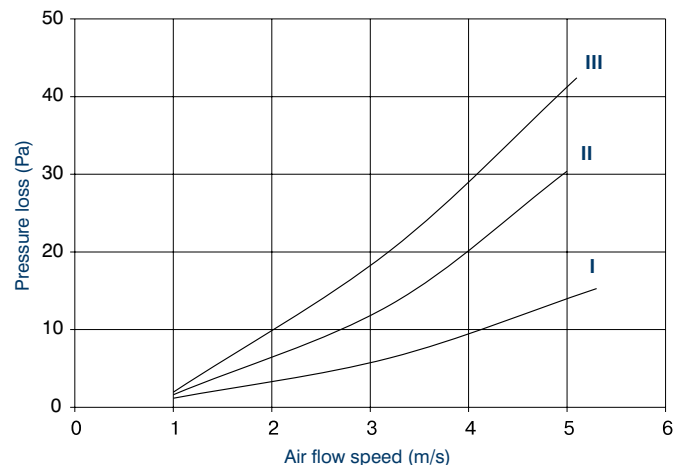

ELECTRIC AIR-HEATERS FOR RECTANGULAR CHANNELS EKN

General information

Electric air-heaters class EKN are designed for air heating in channel rectangular ventilation systems. Shifting air must not contain explosive gas mixtures and aggressive admixtures. Working temperature range is between -40° and +40° C.

Heater case and switchboard are made of steel galvanized sheet. Tubular electric elements are used as heaters. Electric radiators with a power over 7,5 kWt have 2 equal power steps.

Class IP 40 electric insulation.



Indication

EKN 40-20/6



Dimension-types

Dimension type, cm	Power (kW)							
	6	7.5	12	15	22.5	30	45	60
40-20			40-20					
		50-25		50-25	50-25			
		50-30		50-30	50-30			
				60-30	60-30	60-30		
				60-35	60-35	60-35		
				70-40		70-40	70-40	70-40
				80-50		80-50	80-50	80-50
						90-50	90-50	90-50
							100-50	100-50

Dimensions and weight

Dimension type	Dimensions, mm								Mass, kg
	A	B	C	D	E	F	G	H	
EKN 40-20/6	400	200	420	220	440	240	510	390	16
EKN 40-20/12	400	200	420	220	440	240	510	510	16,5
EKN 50-25/7,5	500	250	520	270	540	290	610	390	11
EKN 50-25/15	500	250	520	270	540	290	610	510	15
EKN 50-25/22,5	500	250	520	270	540	290	610	630	19
EKN 50-30/7,5	500	300	520	320	540	340	610	390	11,5
EKN 50-30/15	500	300	520	320	540	340	610	510	15,7
EKN 50-30/22,5	500	300	520	320	540	340	610	630	19,8
EKN 60-30/15	600	300	620	320	640	340	710	510	16,8
EKN 60-30/22,5	600	300	620	320	640	340	710	630	22,4
EKN 60-30/30	600	300	620	320	640	340	710	750	26,4
EKN 60-35/15	600	350	620	370	640	390	710	510	17,5
EKN 60-35/22,5	600	350	620	370	640	390	710	630	23
EKN 60-35/30	600	350	620	370	640	390	710	750	27
EKN 70-40/15	700	400	720	420	740	440	807	510	20
EKN 70-40/30	700	400	720	420	740	440	807	513	31
EKN 70-40/45	700	400	720	420	740	440	828	753	38
EKN 70-40/60	700	400	720	420	740	440	828	753	38

Dimension type	Dimensions, mm								Mass, kg
	A	B	C	D	E	F	G	H	
EKN 80-50/15	800	500	820	520	840	540	910	510	21,4
EKN 80-50/30	800	500	820	520	840	540	910	513	34,5
EKN 80-50/45	800	500	820	520	840	540	930	753	40,5
EKN 80-50/60	800	500	820	520	840	540	930	753	40,5
EKN 90-50/30	900	500	930	530	960	560	960	513	35,5
EKN 90-50/45	900	500	930	530	960	560	960	753	41,5
EKN 90-50/60	900	500	930	530	960	560	960	753	41,5
EKN 100-50/45	1000	500	1030	530	1060	560	1060	753	43,5
EKN 100-50/60	1000	500	1030	530	1060	560	1060	753	43,5

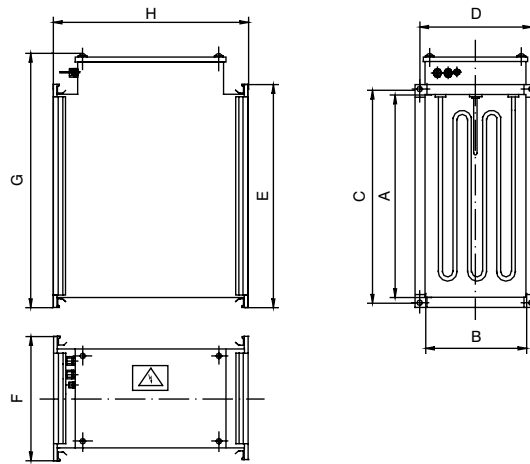

Protection and power control

Electric heaters of EKN type are fitted with protective air and case overheating thermostats and a chain of thermostats which breaks when overheated.

Maximum air temperature at the outlet of a heater shall not exceed 40 C.

Exploitation of the heater with the air-speed below 1-2 m/sec is not allowed.

In case ventilation system is switched off manually, first it is necessary to turn off the heater, and only after TEHs (tubular electric heaters) are cooled - ventilator.

Channel filters are necessary to be installed at the distance not less then 1-1,5 m from the heater.

It is recommended to connect the heaters to the control blocks of type PUA which provide full protection and control of the radiator. When connecting to the control block the regulation of the heater power is implemented in one step or two steps by the contactor built into the control block.

Operating characteristics

The diagram provides curves of the necessary power of the electric radiators depending on consumption and required air heating

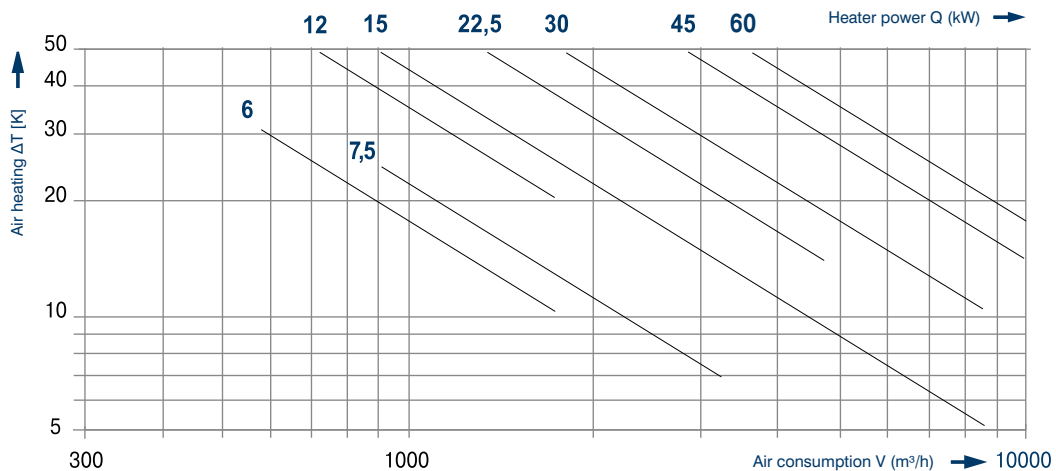

Aerodynamic characteristics

EKN 40-20/6	III	EKN 70-40/15	I
EKN 40-20/12	V	EKN 70-40/30	II
EKN 50-25/7,5	II	EKN 70-40/45	II
EKN 50-25/15	IV	EKN 70-40/60	III
EKN 50-25/22,5	V	EKN 80-50/15	I
EKN 50-30/7,5	II	EKN 80-50/30	I
EKN 50-30/15	IV	EKN 80-50/45	I
EKN 50-30/22,5	V	EKN 80-50/60	I
EKN 60-30/15	III	EKN 90-50/30	I
EKN 60-30/22,5	IV	EKN 90-50/45	II
EKN 60-30/30	V	EKN 90-50/60	II
EKN 60-35/15	II	EKN 100-50/45	II
EKN 60-35/22,5	III	EKN 100-50/60	II
EKN 60-35/30	IV		

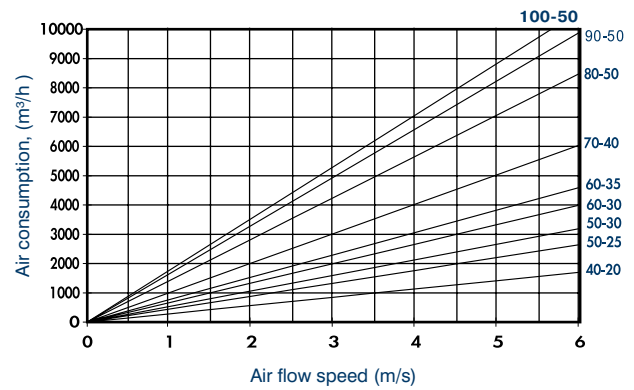
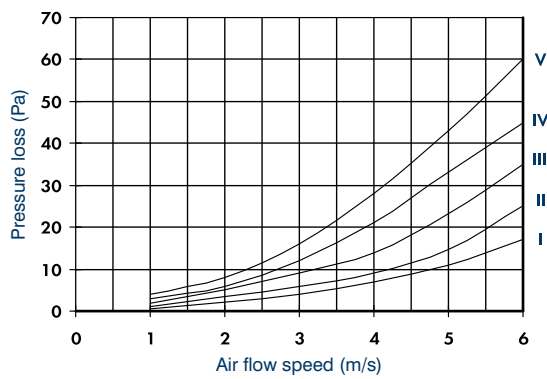

Technical data

Indication	Current	Power	Voltage	Power supply heat.	Feeder cable, q-ty	Protective circuit
EKN.../6	9,1	6	380	BBГ 4x2,5	1	ПВС 2x0,75
EKN.../12	18,1	12	380	BBГ 4x1,5	2	ПВС 2x0,75
EKN.../7,5	11,3	7,5	380	BBГ 4x2,5	1	ПВС 2x0,75
EKN.../15	22,6	15	380	BBГ 4x2,5	2	ПВС 2x0,75
EKN.../22,5	33,9	22,5	380	BBГ 4x2,5	2	ПВС 2x0,75
EKN.../30	45,1	30	380	BBГ 4x6	2	ПВС 2x0,75
EKN.../45	67,6	45	380	BBГ 4x10	2	ПВС 2x0,75
EKN.../60	90,1	60	380	BBГ 4x10	2	ПВС 2x0,75

FREON AIR-HEATERS FOR RECTANGULAR CHANNELS KFO

General information

Freon evaporators of KFO type are designed for air cooling in the channel systems of air conditioning. Coolers are mounted directly in the air ducts of rectangular cross section. The shifting air must not contain aggressive admixtures. In the direct KFO evaporators freon R22, R407C can be used as refrigerating mediums.

Heat exchanger and drip pocket are installed inside the case (made of galvanized sheet) of the cooler. Heat exchangers of KFO coolers are made of copper pipes 9,52 mm in diameter with aluminium ribbing. The pipes are staggered. Heat exchangers are made 3-row with "left" side for connection.

Drip pocket consists of set of special plastic plates which effectively collect condensate and store it in a pallet in the lower part of the cooler case. The pallet is extra heat-insulated and fitted with outlet for the condensate drain.

Freon evaporators KFO are as a standard fitted with capillary thermostat for the protection of heat exchanger from air frosting.

When delivered evaporators are drained and filled with a rare gas.

Coolers shall be mounted in horizontal position.

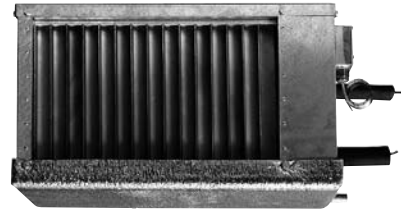

Indication of freon coolers

KFO 70-40

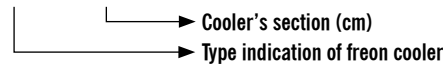

Dimensions of freon coolers

Indication	Dimensions, mm								Mass, kg
	A	B	C	D	E	F	G	H	
KFO 40-20	504	287	220	420	95	45	12	16	16
KFO 50-25	604	337	270	520	125	50	12	16	18
KFO 50-30	604	387	320	520	155	50	16	22	19
KFO 60-30	704	387	320	620	155	60	16	22	21
KFO 60-35	704	437	370	620	195	45	16	22	23
KFO 70-40	804	387	420	720	220	45	16	28	26
KFO 80-50	904	587	520	820	290	53	22	28	32
KFO 90-50	1014	607	530	930	330	55	28	35	36
KFO 100-50	1114	607	530	1030	330	55	28	35	40

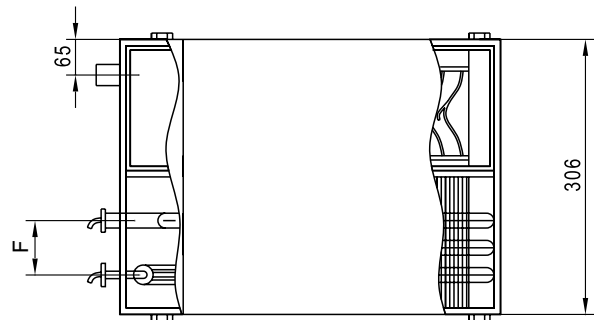
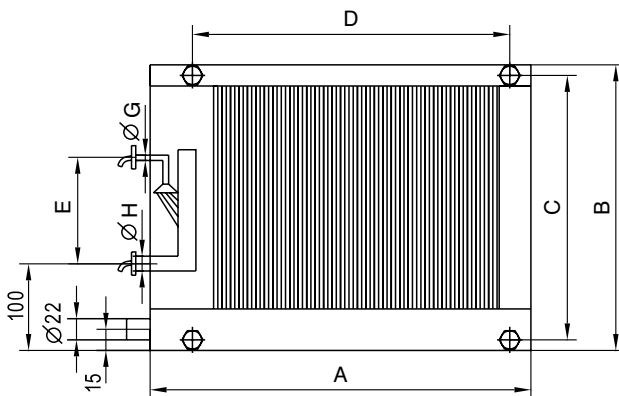

Characteristics of freon coolers

Aerodynamic characteristics of coolers

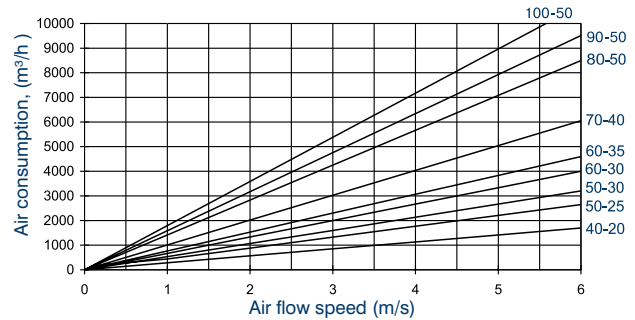
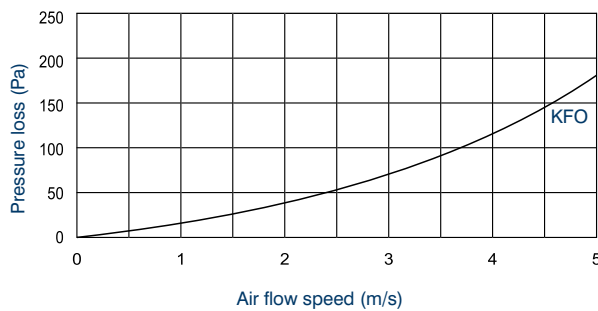

Thermotechnical characteristics of freon coolers

Dimension type	Air consumption, m.cub./h	Output air, C	Cooling efficiency, kW
40-20	1150	19	6,54
50-25	1800	19	10,24
50-30	2150	19	12,23
60-30	2600	19	14,79
60-35	3020	19	17,18
70-40	4030	19	22,9
80-50	5750	19	32,71
90-50	6480	19	36,87
100-50	7200	19	40,96

Outside air temperature $T_p=30^\circ\text{C}$
 Humidity 45%
 Freon boiling point (R407) 5°C

The table provides information on individual function modes of coolers. Selection of freon coolers for particular conditions is made with a special computer program "EVR".

WATER AIR-COOLERS FOR RECTANGULAR CHANNELS KWO

General information

Water air-coolers of KWO type are designed for air cooling in channel systems of air conditioning. Coolers are mounted directly in the air ducts of rectangular cross section. The shifting air must not contain aggressive admixtures.

Water and other anti-freeze mixtures can be used in the KWO coolers. Maximum allowed pressure of the cool carrier in water coolers is 1,5 MPa.

Heat exchanger and drip pocket are installed inside the case (made of galvanized sheet) of the cooler.

Heat exchangers of KWO coolers are made of copper pipes 9,52 mm in diameter with aluminium ribbing. The pipes are staggered.

Heat exchangers are made 3-row with "left" connection side.

Drip pocket consists of the set of special plastic plates which effectively gather condensate and collect it in a pallet in the lower part of the cooler case. The pallet is extra heat-insulated and fitted with outlet for water drain. Coolers shall be mounted in the horizontal position.

Each heat exchanger is checked for impermeability by by molding at 20 Atm pressure for 10 min.



Indication for water coolers

KWO 70-40

- Cooler's section (cm)
- Type indication of water cooler

Ūdens dzesētāju Dimensions

Indication	Dimensions, mm				Mass, kg
	A	B	C	D	
KWO 40-20	520	290	420	420	16
KWO 50-25	620	340	520	270	19
KWO 50-30	620	390	520	320	21
KWO 60-30	720	390	620	320	23
KWO 60-35	720	440	620	370	25
KWO 70-40	820	490	720	420	28
KWO 80-50	920	590	820	520	38
KWO 90-50	1025	600	930	530	42
KWO 100-50	1125	600	1030	530	46

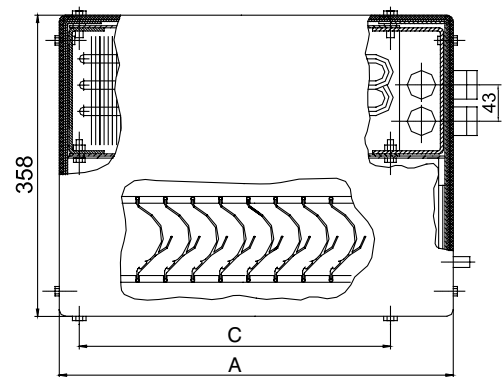
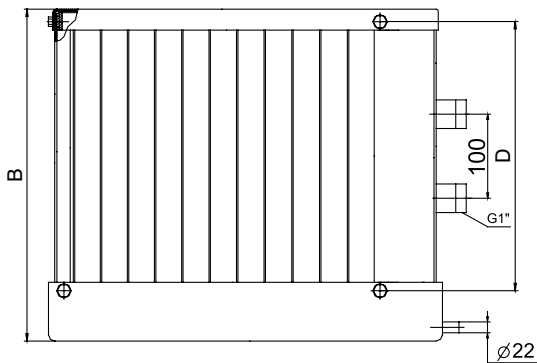

Characteristics of water coolers

Aerodynamic characteristics of coolers

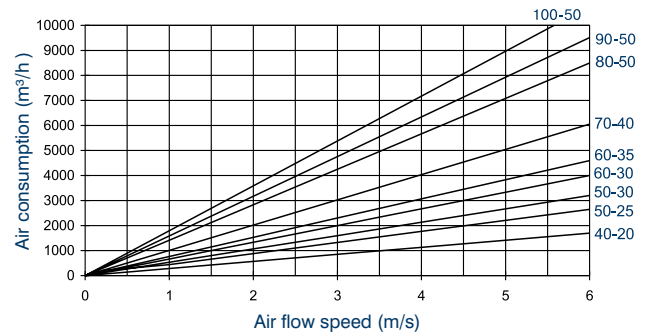
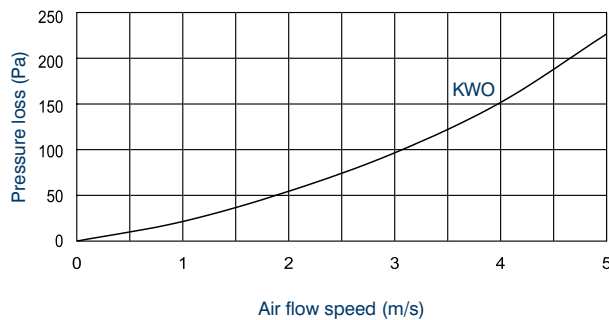

Hydraulic characteristics of water air-coolers

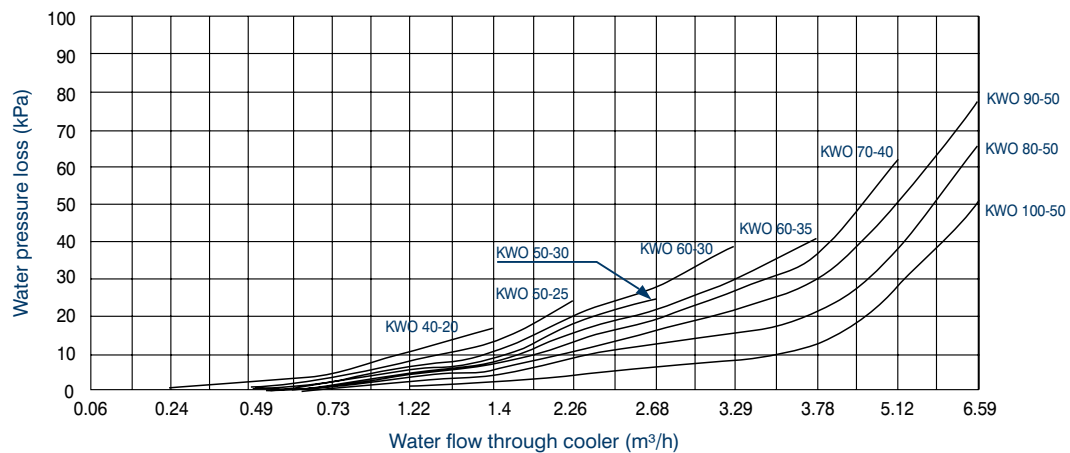

Thermotechnical characteristics of water coolers

Dimension type	Air consumption, m ³ /h	Water consumption, m ³ /h	Output air, C	Cooling efficiency, kW
40-20	1150	0,95	20	5,39
50-25	1800	1,48	20	8,43
50-30	2150	1,77	20	10,07
60-30	2600	2,14	20	12,18
60-35	3020	2,48	20	14,15
70-40	4030	3,31	20	18,9
80-50	5750	4,73	20	26,94
90-50	6480	5,33	20	30,36
100-50	7200	5,95	20	33,73

Outside air temperature $T_H = 30^\circ \text{C}$

Humidity 45%

Water temperature $7/12^\circ \text{C}$

PLATE-TYPE RECUPERATORS FOR RECTANGULAR CHANNELS RPK

General information

Lamellar recuperators of RPK type are designed for utilization of heat of the extracted air in ventilation and condensation systems. Recuperators are directly connected to the air ducts of rectangular cross section. Shifting air must not contain aggressive admixtures.

The case of recuperator is made of steel galvanized sheet. Heat-exchange surface is a set of special aluminium plates 0,2mm thick which ensure highly effective heat transmission.

Recuperators allow collection of some amount of condensate (which may appear on the air-ejector surfaces of a heat exchange) on the lower removable panel. Delivery set of the lamellar recuperators as a standard includes connecting pipe for the condensation drainage which can be mounted on the lower panel.



Indication of recuperators

RPK 70-40

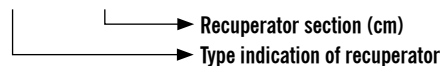

Overall and fitting dimensions

Indication	Dimensions, mm								Mass, kg
	A	B	C	D	E	F	G	H	
RPK 40-20	420	220	516	260	516	516	474	474	25,6
RPK 50-25	520	270	616	360	616	616	574	574	35,6
RPK 50-30	520	270	616	360	616	616	574	574	35,6
RPK 60-30	620	320	716	360	716	716	674	674	46,6
RPK 60-35	620	370	716	410	716	716	674	674	48,6
RPK 70-40	720	420	816	460	816	816	774	774	64,6
RPK 80-50	820	520	916	560	916	916	874	874	85,6
RPK 90-50	930	530	1016	560	1016	1016	974	974	92
RPK 100-50	1030	530	1116	560	1116	1116	1074	1074	105,6

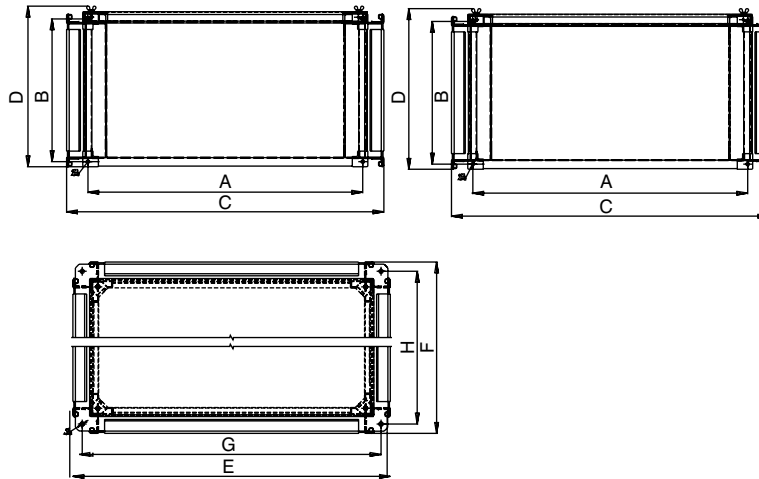

Technical characteristics

Basic characteristics of lamellar recuperators are its effectiveness, t.i. efficiency factor, as well as resistance in the air duct system. Heat efficiency factor is determined by the following formula, where:

$$\eta = \frac{t_i - t_u}{t_f - t_u}$$

t_u - outside air temperature
 t_f - removed air temperature (before recuperation)
 t_i - supply air temperature (after recuperation)

Effectiveness of lamellar recuperators PR depending on air flow speed

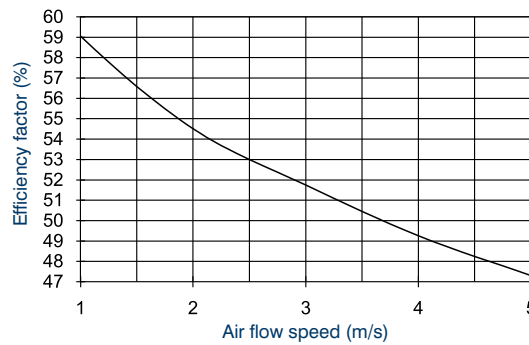

Aerodynamic characteristics of recuperators

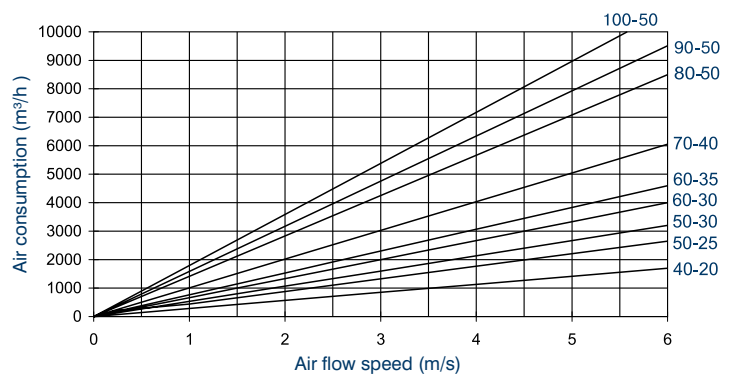
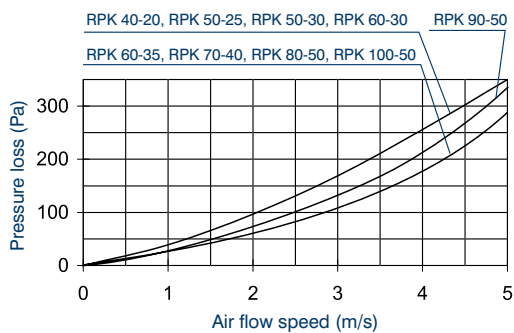

CASSETTE FILTERS FOR ROUND CHANNELS FKK

General information

Cassette filters FKK are designed for air cleaning in round air channels. The passing air temperature – up to +70°C.

Construction and materials

Filter casing and lid are made from a galvanized steel sheet. Filter medium is plate made of a synthetic fiber and has the air cleaning class – EU 3.



Dimension-types and basic technical information

Dimension type	A	B	C	Mass, kg	Inserts applied
FKK 100	136	140	100	1,25	FWK100
FKK125	166	170	125	1,52	FWK125
FKK 160	196	200	160	1,81	FWK160
FKK 200	241	245	200	2,36	FWK 200
FKK 250	291	295	250	3,04	FWK250
FKK 315	356	360	315	3,94	FWK 315

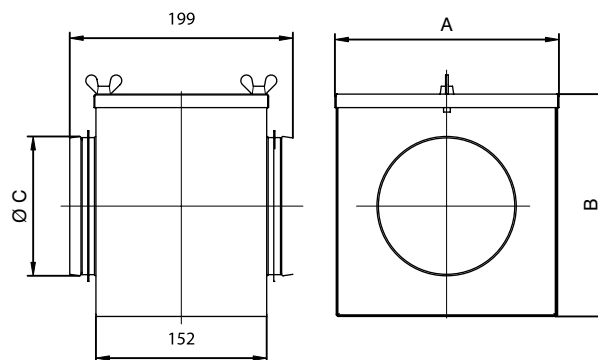

Aerodynamic characteristics

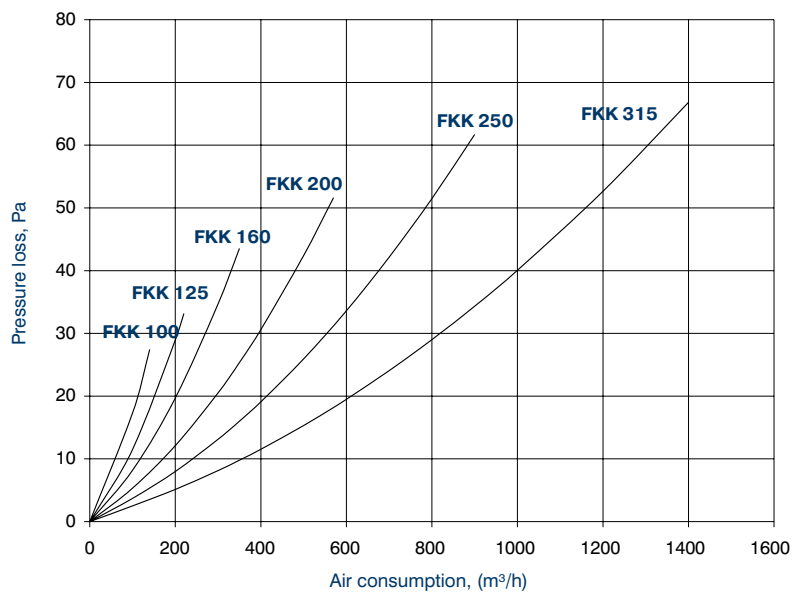

CASSETTE FILTERS FOR ROUND CHANNELS KFK

General information

Channel cassette filters of KFK type are designed for air cleaning in the channel rectangular ventilation systems. Air cleaning class – EU 3. Shifting air temperature is up to +70° C.

Case of a filter and case of a cassette with a filter element is made of steel galvanized sheet. Filtering material is made of synthetic fibre and fixed to the cassette through a wire screen.



Indication for cassette filters

KFK 40-20

- Size of a connecting flange (cm)
- Size of a connecting flange (cm)
- Type indication of cassette filter

WFK 40-20

- Dimension-type of the inset for the KFK filter
- Type indication of the cassette for the KFK filter

Dimensions and weight of cassette filters

Indication	Dimensions, mm								Mass, kg
	A	B	C	D	E	F	G	H	
KFK 40-20	400	200	420	220	440	240	9	242	4,0
KFK 50-25	500	250	520	270	540	290	9	242	4,8
KFK 50-30	500	300	520	320	540	340	9	242	5,1
KFK 60-30	600	300	620	320	640	340	9	242	5,4
KFK 60-35	600	350	620	370	640	390	9	242	5,7
KFK 70-40	700	400	720	420	740	440	9	242	6,8
KFK 80-50	800	500	820	520	840	540	9	242	11,0
KFK 90-50	900	500	930	530	960	560	13	260	15,0
KFK 100-50	1000	500	1030	530	1060	560	13	260	19,0

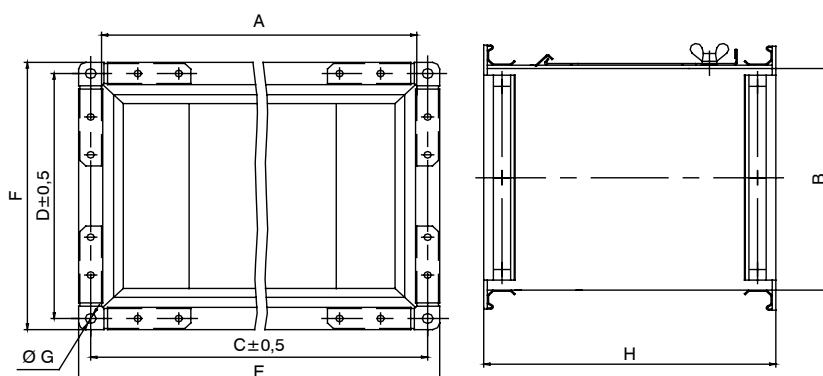

Aerodynamic characteristics

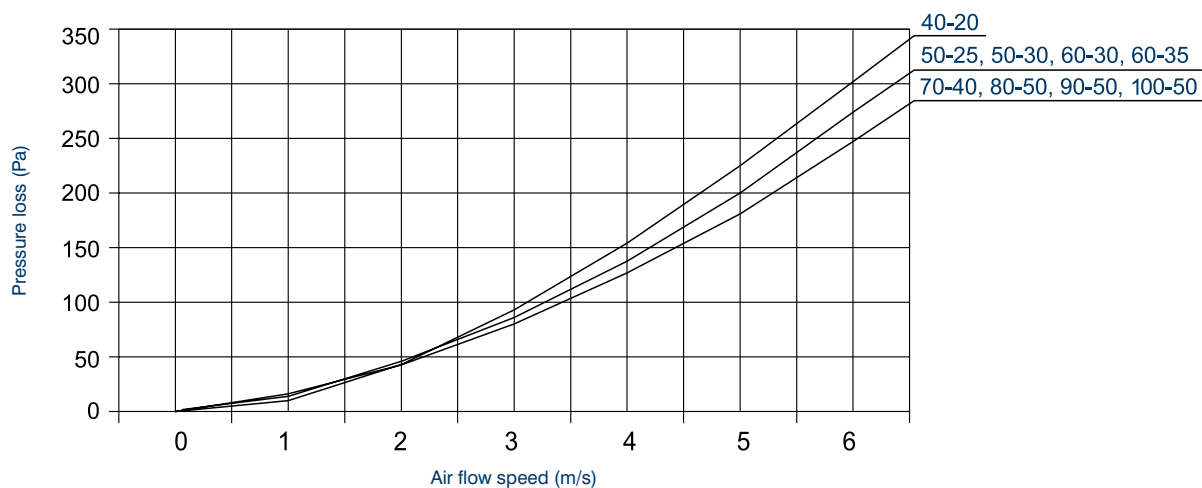

Dependence of air flow speed on air consumption for filters of KFK type

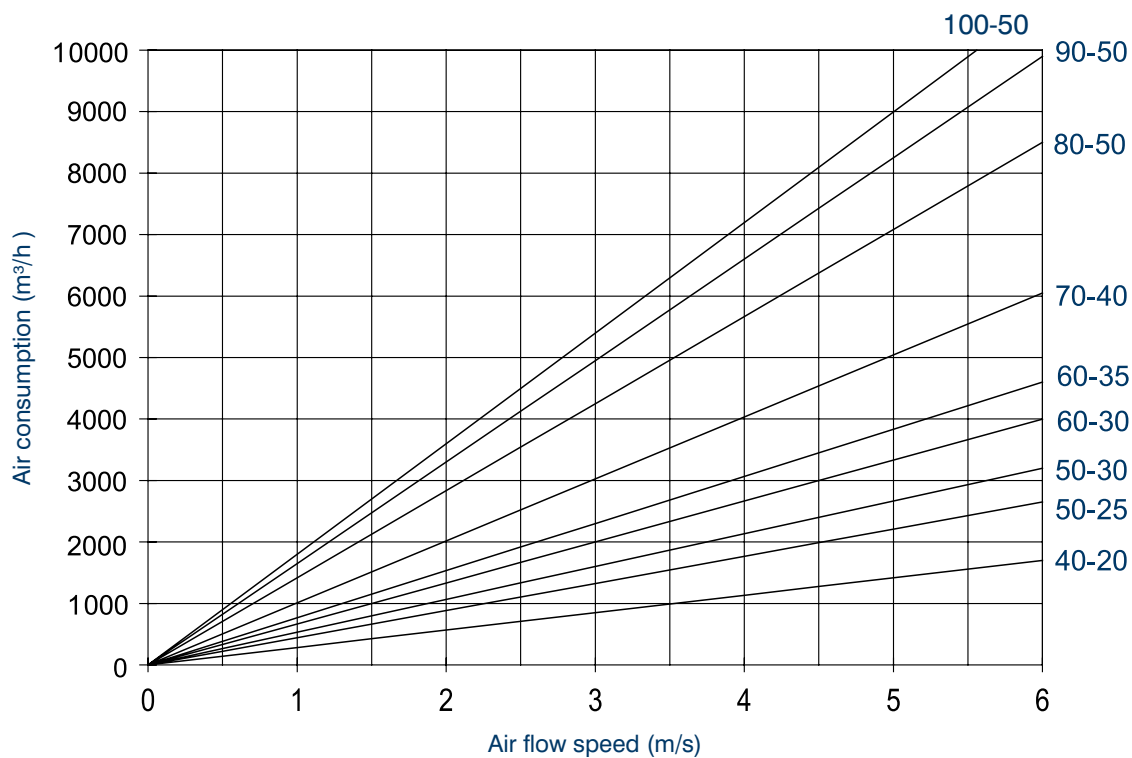

POCKET FILTERS FOR RECTANGULAR CHANNELS KFR AND KFU

General information

Channel cassette filters of KFR and KFU types are designed for air cleaning in channel rectangular ventilation systems. Shifting air temperature is up to +70° C. Case of the filters is made of steel galvanized sheet. Filter inset is a cassette of a bag type made of synthetic material. Filters of KFU type have a shorter pocket length comparing to KFR filters.

Filter insets WUF for the KFU filters are of air cleaning class EU 3. Filter insets WRF for the KFU filters are of air cleaning classes EU 3, EU 5, EU 7.

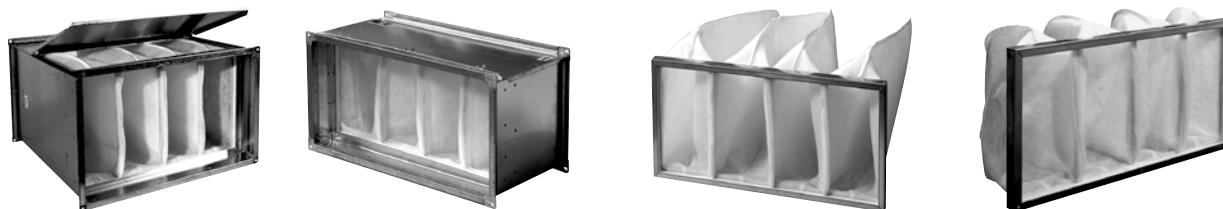

Indication of pocket filters

KFR 40-20 (G3)

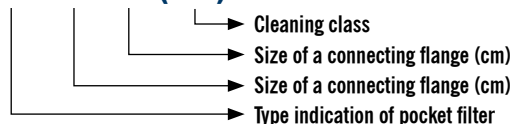

KFU 40-20 (G3)

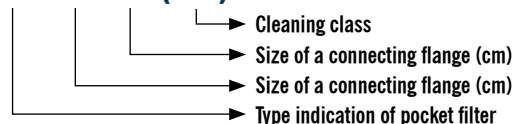

WRF 40-20 (G3)

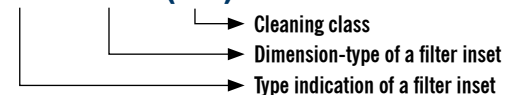

WUF 40-20 (G3)

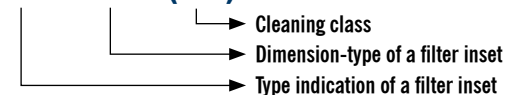

KFU kabatu filtru Dimensions un svars

Indication	Dimensions, mm								Mass, kg	Q-ty of pockets (inset)
	A	B	C	D	E	F	G	H		
KFU 40-20	400	200	420	220	440	240	9	330	5	3
KFU 50-25	500	250	520	270	540	290	9	330	6,2	4
KFU 50-30	500	300	520	320	540	340	9	330	7	4
KFU 60-30	600	300	620	320	640	340	9	330	8	4
KFU 60-35	600	350	620	370	640	390	9	330	8	4
KFU 70-40	700	400	720	420	740	440	9	330	9	5
KFU 80-50	800	500	820	520	840	540	9	330	14,6	5
KFU 90-50	900	500	930	530	960	560	13	340	16	5
KFU 100-50	1000	500	1030	530	1060	560	13	340	17,4	6

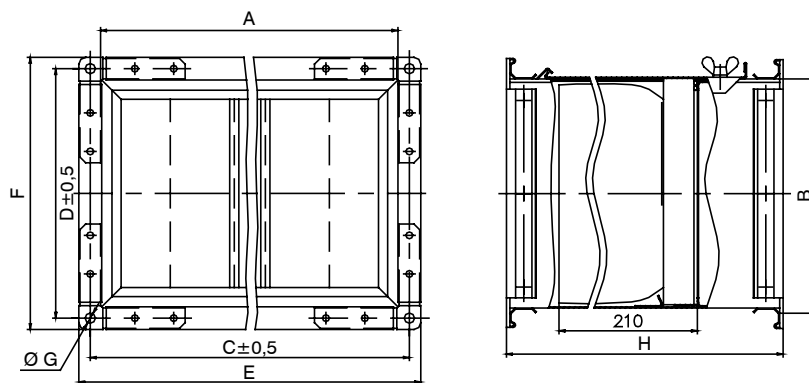

Dimensions and weight of pocket filters KFR

Indication	Dimensions, mm									Mass, kg	Q-ty of pockets (inset)
	A	B	C	D	E	F	G	H	I		
KFR 40-20	400	200	420	220	440	240	9	540	420	6,5	3
KFR 50-25	500	250	520	270	540	290	9	640	520	9	4
KFR 50-30	500	300	520	320	540	340	9	640	520	10	4
KFR 60-30	600	300	620	320	640	340	9	640	520	11	4
KFR 60-35	600	350	620	370	640	390	9	640	520	11,8	4
KFR 70-40	700	400	720	420	740	440	9	720	600	14	5
KFR 80-50	800	500	820	520	840	540	9	800	680	24	5
KFR 90-50	900	500	930	530	960	560	13	820	680	28	5
KFR 100-50	1000	500	1030	530	1060	560	13	820	680	32	6

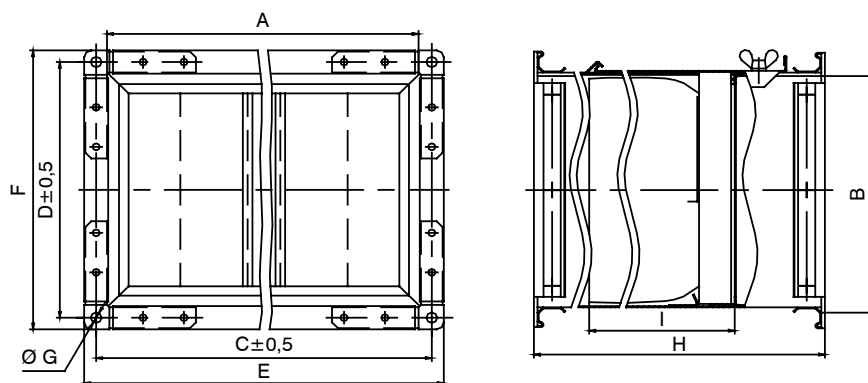

Pocket filters of type KFU G3

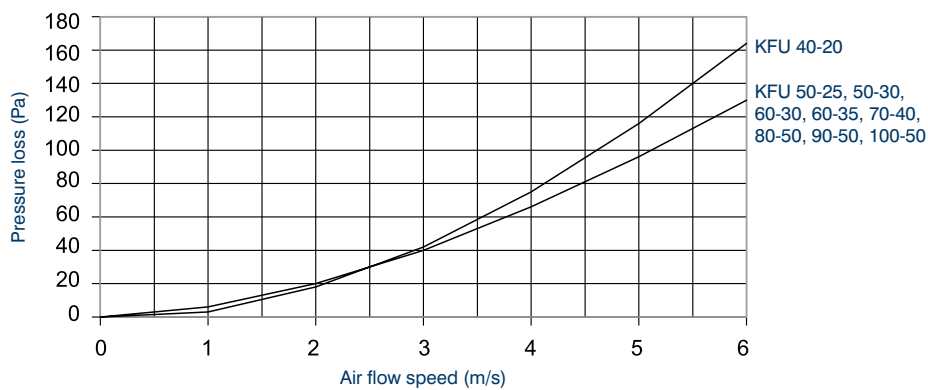

KFR tipa kabatu filtri

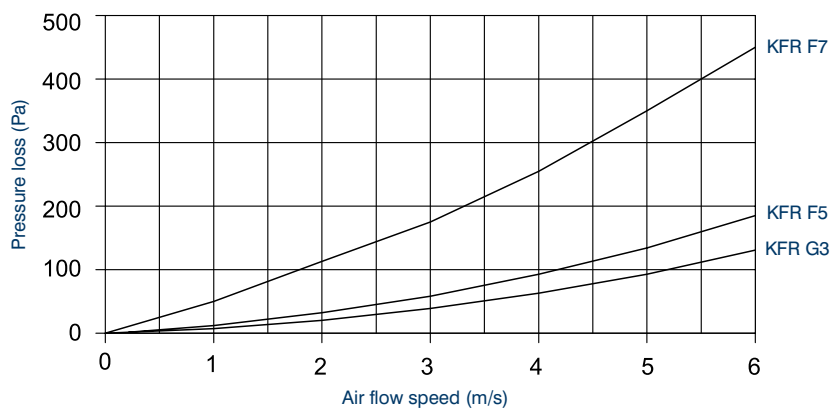

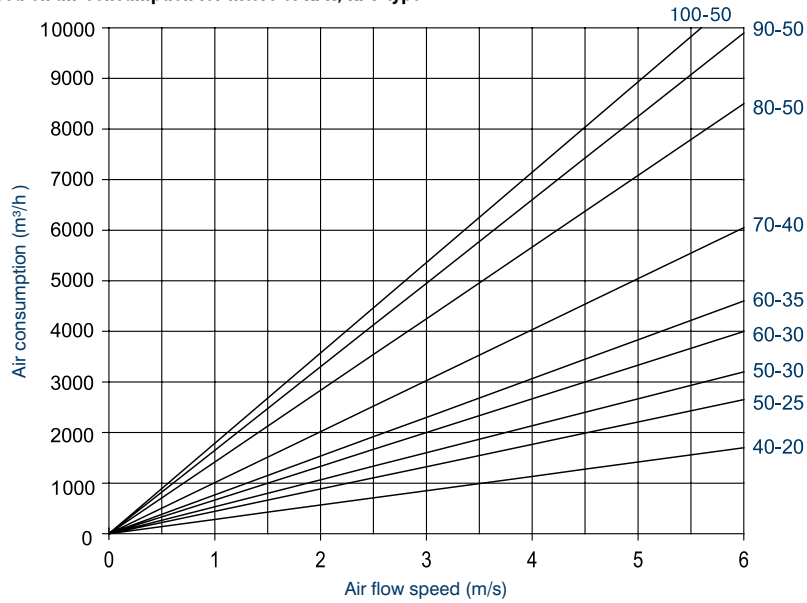
Dependence of air flow speed on air consumption for filters of KFR, KFU type

ADJUSTING CHOKES FOR ROUND CHANNLES ZOK
General information

Adjusting chokes FKK are designed for air flow control and round air channel shutdown. Shifting air temperature range – from - 40 up to +70° C.

Construction and materials

Choke casing and moving blade are made from a galvanized steel sheet. The blade has a sealing rubber. Chokes can be adjusted manually or by electric drive. The section of a stem for drive connection – square with a 8 mm side.

Dimensions and weight

Indication	A	B	C	Mass, kg
ZOK 100	200	163	100	0,36
ZOK 125	200	193	125	0,52
ZOK 160	200	225	160	0,73
ZOK 200	200	272	200	1,02
ZOK 250	260	325	250	1,49
ZOK 315	260	390	315	2,10

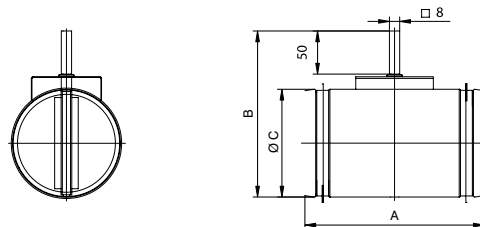
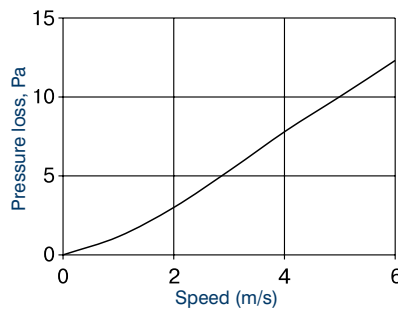
Aerodynamic characteristics

ADJUSTING CHOKES FOR RECTANGULAR CHANNELS ZOR

General information

Adjusting screens of ZOR type are designed for regulation of air consumption and blocking of rectangular channels of ventilation systems. Shifting air temperature is between -40° and $+70^{\circ}$ C.

Case of the screen is made of steel galvanized sheet. Variable-incidence blades are made of special aluminium profile and are fitted with pressurizing rubber seals. The plates drive is implemented through the system of the wearproof plastic cog-wheels. Each screen is fitted with a rod (section - square with 10 mm side) for the connection of regulating servo-motor.



Indication of screens

ZOR 40-20

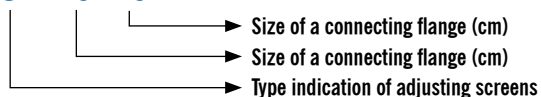

Dimensions and weight of the screens

Indication	Dimensions, mm								Mass, kg, without motor
	A	B	C	D	E	F	G	H	
ZOR 40-20	400	200	420	220	440	240	9	168	5,1
ZOR 50-25	500	250	520	270	540	290	9	168	6,0
ZOR 50-30	500	300	520	320	540	340	9	168	7,0
ZOR 60-30	600	300	620	320	640	340	9	168	8,0
ZOR 60-35	600	350	620	370	640	390	9	168	8,0
ZOR 70-40	700	400	720	420	740	440	9	168	10
ZOR 80-50	800	500	820	520	840	540	9	168	12
ZOR 90-50	900	500	930	530	960	560	13	171	16,5
ZOR 100-50	1000	500	1030	530	1060	560	13	171	21

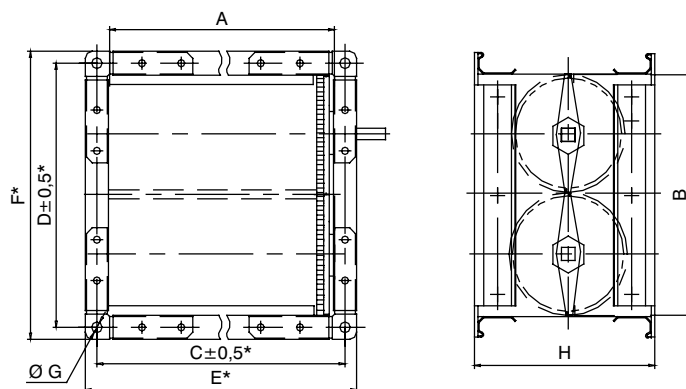

Aerodynamic characteristics

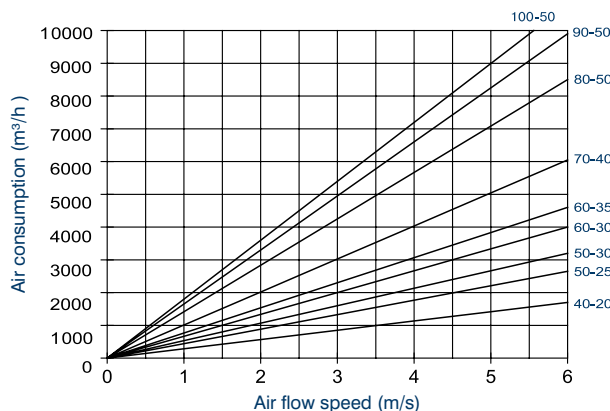
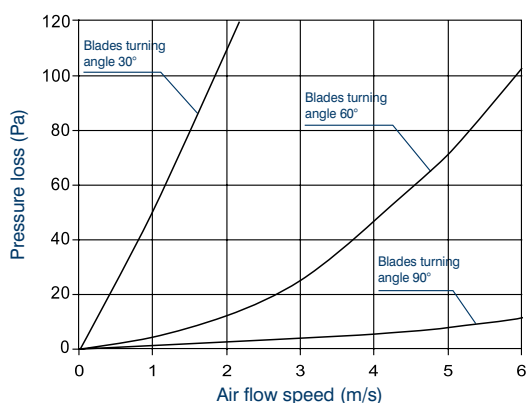

RETURN VALVES FOR ROUND CHANNELS OPK

General information

Return valve OPK with spring-loaded blades provides automatic shutdown of round air ducts when ventilator is switched off. Return valves can be mounted in any position.

Construction and materials

Return valve's casing is made of a galvanized steel sheet, blades are made of a sheet aluminium. The construction of return valve allows mounting with air ducts and other ventilation system elements with the help of clamps.



Dimensions and weight

Dimension type	A	B	C	D	Mass, kg
OPK 100	80	27	35	100	0,16
OPK 125	100	37	45	125	0,25
OPK 160	110	37	55	160	0,35
OPK 200	140	52	70	200	0,55
OPK 250	140	47	75	250	0,71
OPK 315	140	47	75	315	0,91

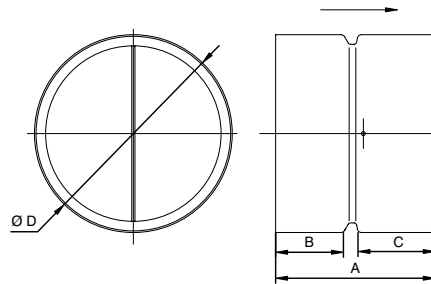

Aerodynamic characteristics

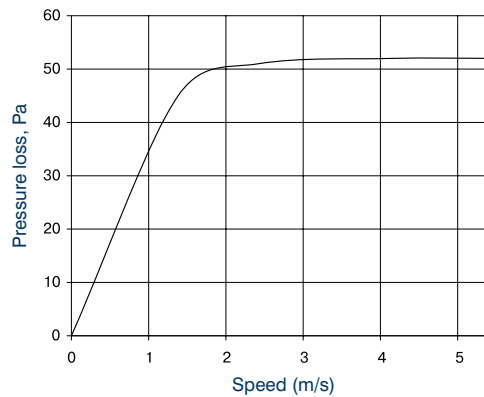

MUFFLERS FOR ROUND CHANNELS KSK

General information

Lamellar-type mufflers KSK ensure noise level reduction in round air ducts. The maximal temperature of a shifting air is 70° C.

The mufflers can be mounted in any position.

Construction and materials

Muffler casing is made of a galvanized steel sheet. Noise absorbing material is a mineral fiber.



Dimensions and weight

Indication	A	B	C	D	Mass, kg
KSK 100/6	600	200	730	100	3,85
KSK 100/9	900		1030		5,96
KSK 125/6	600	224	730	125	4,92
KSK 125/9	900		1030		7,88
KSK 160/6	600	280	730	160	7,02
KSK 160/9	900		1030		8,85
KSK 200/6	600	315	730	200	7,88
KSK 200/9	900		1030		11,20
KSK 250/6	600	355	730	250	9,82
KSK 250/9	900		1030		12,96
KSK 315/6	600	500	730	315	13,40
KSK 315/9	900		1030		19,00

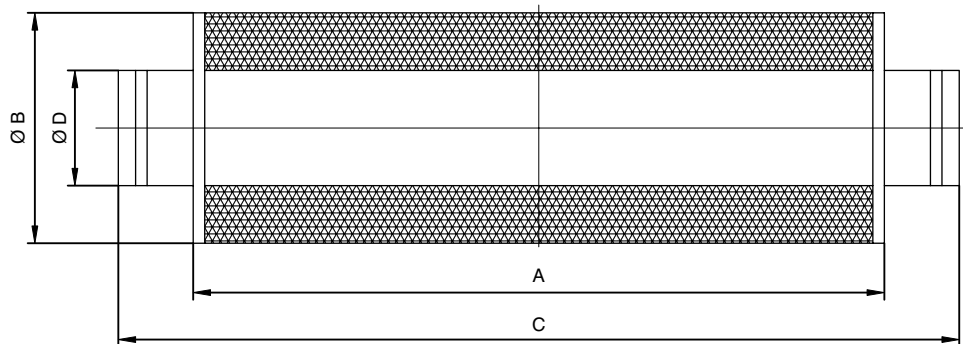

Acoustic characteristics

Dimension type	Noise reduction (dB) at frequency band, Hz							
	63	125	250	500	1000	2000	4000	8000
KSK 100/6	4,5	6,3	15	20,5	30,5	32,3	30,2	16
KSK 100/9	6,3	8,5	15	24	32,6	35,5	30,3	21,3
KSK 125/6	4,2	6	12,5	16,3	25,6	23,4	24,3	17,5
KSK 125/9	5,6	9,5	17,6	29	35,4	38	34,5	20,1
KSK 160/6	3,5	5,3	11,2	15,5	23	31,6	23	16,2
KSK 160/9	4	7,8	16,2	22,8	33	36,2	32,6	19,5
KSK 200/6	3,6	4	8	14	20,3	28,5	18,2	15,3
KSK 200/9	3	6,5	12,5	18,2	28,5	33	21,6	18,3
KSK 250/6	1,5	2,3	7,3	13,5	19,3	22,6	13	11
KSK 250/9	2,5	3	9,1	15	26,8	27,5	16,8	13,6
KSK 315/6	0,5	1,5	3	11	14	19	8	7
KSK 315/9	1,3	2,6	7,5	14,3	23,5	21	12	9

MUFFLERS FOR ROUND CHANNELS KSG

General information

Mufflers of type KSG are designed to reduce aerodynamic noise of air flow in the rectangular channels of ventilation systems. Maximum temperature of the shifting air is 70° C.

Case of the muffler is made of steel galvanized sheet. Noise-absorbing plates are made of the basalt-fibrous mineral-cotton wool plate upholstered with felt, preventing the plates blowing out.

Mufflers can be mounted in any position.



Indication of mufflers

KSG 40-20

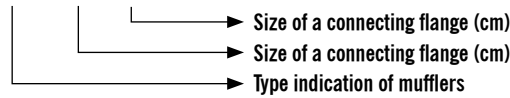

Dimensions and weight of mufflers

Indication	Dimensions, mm								Mass, kg
	A	B	C	D	E	F	G	H	
KSG 40-20	400	200	420	220	440	240	9	1014	26
KSG 50-25	500	250	520	270	540	290	9	1014	27
KSG 50-30	500	300	520	320	540	340	9	1014	30
KSG 60-30	600	300	620	320	640	340	9	1014	32
KSG 60-35	600	350	620	370	640	390	9	1014	37
KSG 70-40	700	400	720	420	740	440	9	1014	48
KSG 80-50	800	500	820	520	840	540	9	1014	58
KSG 90-50	900	500	930	530	960	560	13	1016	64
KSG 100-50	1000	500	1030	530	1060	560	13	1016	70

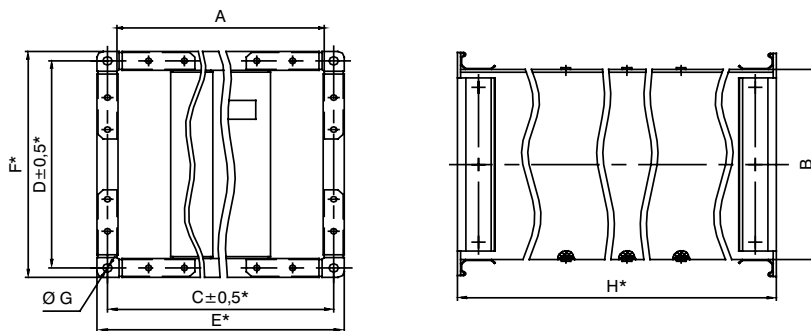

Operational characteristics of mufflers

Aerodynamic characteristics of mufflers KSG type, i.e. dependence of pressure loss on air flow speed in a frontal section, are provided below.

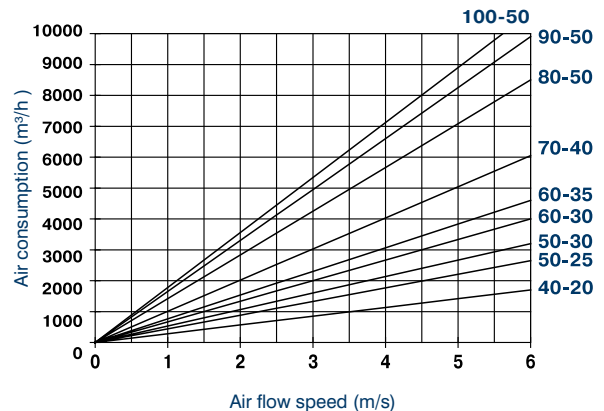
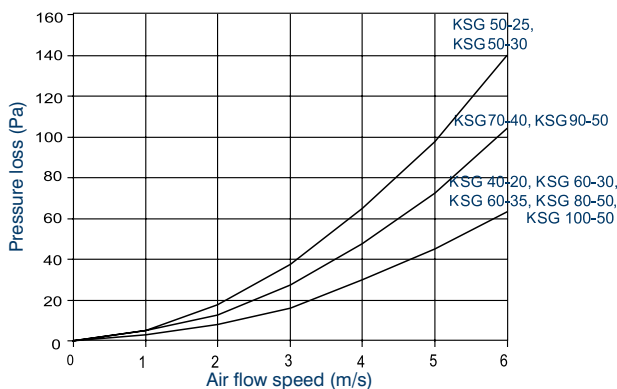

The efficiency of mufflers noise reduction by octave bands is provided in the following table

Dimension-types	Noise reduction (dB) in frequency diapazons, Hz							
	63	125	250	500	1000	2000	4000	8000
KSG 40-20	24,2	19,8	16,6	25,1	32,8	45,5	39,7	32,8
KSG 50-25	22,7	19,2	18,8	28,4	39,9	47,3	51,8	49
KSG 50-30	25,6	20,1	21,7	33	41,8	52,2	53,3	54,9
KSG 60-30	21,2	17	17,3	28,8	37,4	48,3	44,4	35,7
KSG 60-35	16,7	14,6	14,3	24,5	37,6	49,1	41,6	42
KSG 70-40	20,6	16,6	19,2	31,5	42,9	51,9	54,5	49,4
KSG 80-50	19,4	14,4	17,6	22,8	40,7	51,8	50,8	39,5
KSG 90-50	20,5	15,8	20,1	29,4	46,5	54,1	55,3	44,8
KSG 100-50	18,8	14,6	17,3	23,4	41,2	52	51,1	40,3

FLEXIBLE CONNECTOR FOR RECTANGULAR CHANNELS WKG

General information

Flexible insets WKG are designed to absorb mechanical vibrations of rectangular channel ventilators and prevent transmission of these oscillations to air duct systems. The temperature range for the application of insets is — from -40° to +80° C.

Flexible insets are made of steel galvanized rectangular flanges connected one to another with an insulation vinyl tape. Additionally, the flanges are fixed with a conducting wire.

Flexible insets are not designed for mechanical load.



Indication

WKG 40-20

- Size of a connecting flange (cm)
- Size of a connecting flange (cm)
- Type indication of flexible inset

Dimensions and weight

Indication	Dimensions, mm								Mass, kg
	A	B	C	D	E	F	G	H	
WKG 40-20	400	200	420	220	440	240	9	156	2
WKG 50-25	500	250	520	270	540	290	9	156	2,5
WKG 50-30	500	300	520	320	540	340	9	156	2,6
WKG 60-30	600	300	620	320	640	340	9	156	2,9
WKG 60-35	600	350	620	370	640	390	9	156	3
WKG 70-40	700	400	720	420	740	440	9	156	3,5
WKG 80-50	800	500	820	520	840	540	9	156	4
WKG 90-50	900	500	930	530	960	560	11	158	4,5
WKG 100-50	1000	500	1030	530	1060	560	11	158	5

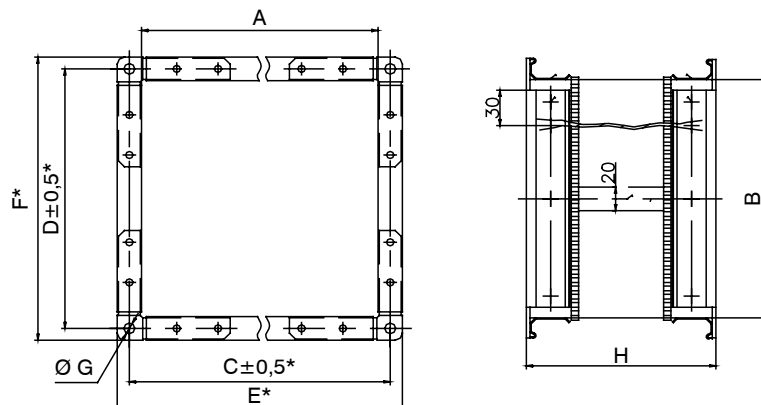

CLAMPS HSK

General information

Quick-dismountable clamps HSK make it easier to mount and dismount elements of round ventilation systems.

Construction and materials

Clamps are made of a galvanized steel sheet, provided with sealing layer reducing vibration and ensuring a tight fit. Quick-dismountable clamps are tightened with two screws.



Dimensions and weight

Dimension type	A	B	C	Mass, kg
HSK 100	118	148	100	0,24
HSK 125	145	174	125	0,27
HSK 160	178	212	160	0,32
HSK 200	218	253	200	0,39
HSK 250	268	304	250	0,46
HSK 315	333	370	315	0,55

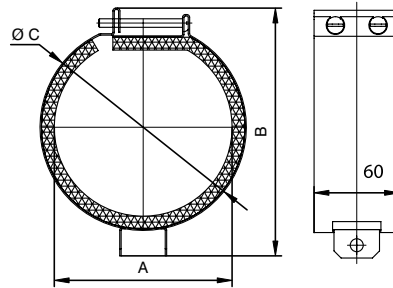

TRANSFORMER RPM REGULATORS TYPE RE... AND RD...

General information

Transformer rpm regulators are used to control ventilators productivity by changing the output voltage. Regulators have five levels of output voltage, which are manually selected with the help of a switch.

Regulators have no possible connections of thermocontacts of ventilators, so it is necessary to consider protective devices, for example STDT16, S-ET10. It is allowed to connect several ventilators to a regulator while their total current does not exceed nominal current for the regulator.

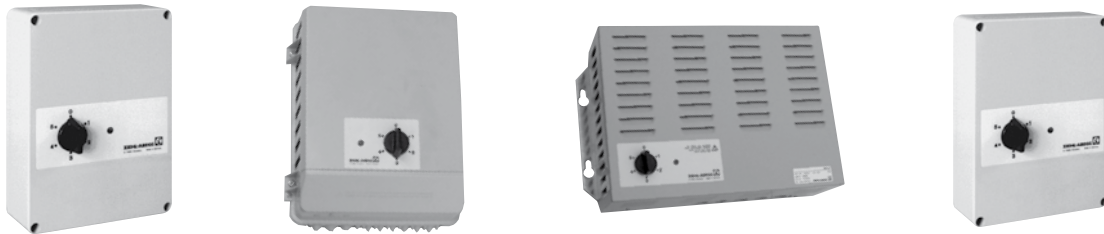

Technical characteristics of RD regulators

Type	Max. current,	Figure	Protection level	Protection device at inlet	Weight, kg
RD 2 G	2	A	IP 54	4	7,3
RD 4	4	B	IP 21	8	12,5
RD 7	7	B	IP 21	16	18,1
RD 14	14	D	IP 21	25	30,2

Nominal voltage: 3 ~ 400 V, 50/60 Hz
 Maximum permissible temperature of the environment: +40C°
 Output voltage is changed by a 5-step switch (95V-145V-190V-240V-400V)

Dimensions of RD regulators

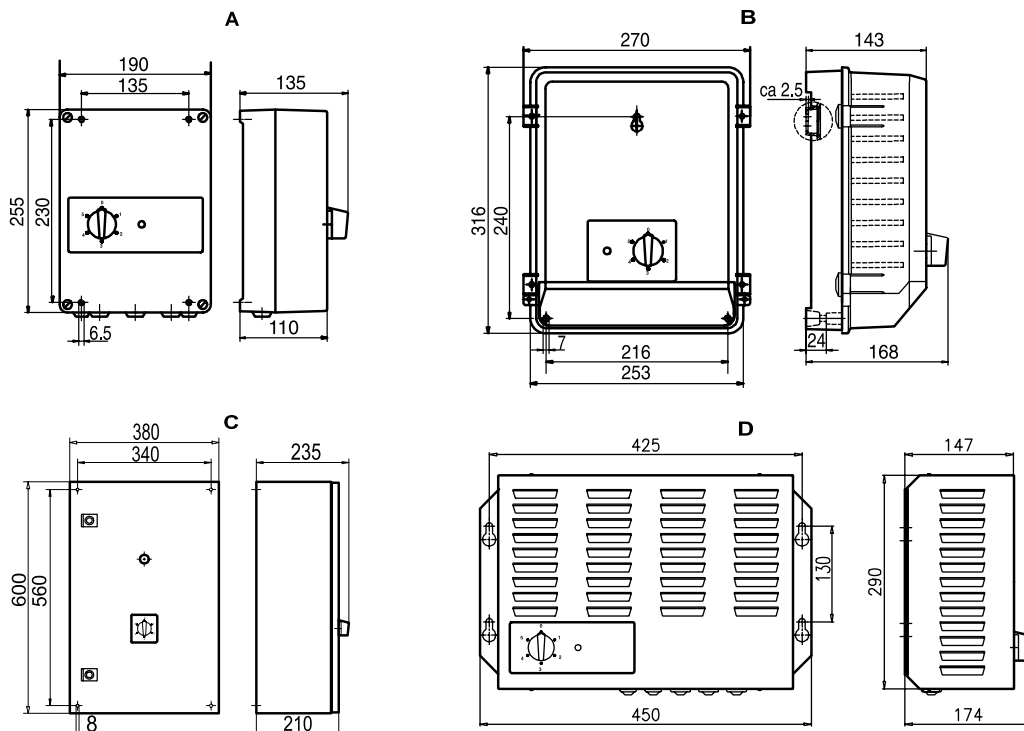

Technical characteristics of RE regulators

Type	Max. current, A	Figure	Protection level	Protection device at inlet	Weight, kg
RE 2 G	2	B	IP 54	4	3,4
RE 6 G	6	B	IP 54	12	6

Nominal voltage: 1 ~ 400 V, 50/60 Hz

Maximum permissible temperature of the environment: +40C°

Output voltage is changed by a 5–step switch (65V-110V-135V-170V-230V).

Dimensions of RE regulators

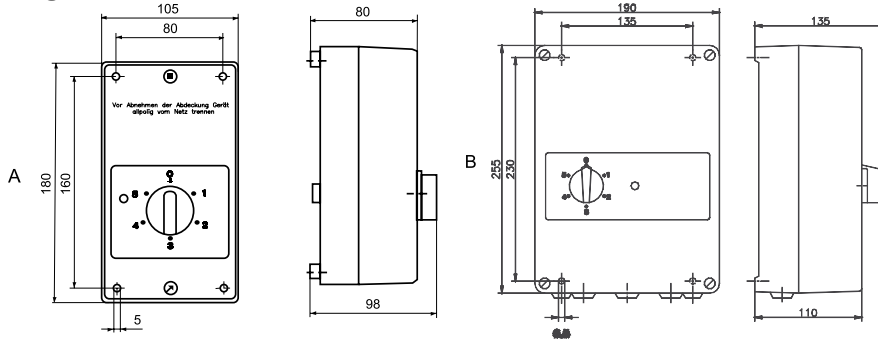

TRANSFORMER RPM REGULATORS TYPE RET... AND RDT...

General information

Transformer rpm regulators are used to control ventilators productivity by changing the output voltage. Regulators have five levels of output voltage, which are manually selected with the help of a switch.

Regulators can be connected with thermocontacts from ventilators.

In the chosen mode (output voltage) it is possible to implement external start-up and shutdown of the regulator with the help of a control contact.

It is possible to connect several ventilators to a regulator, while their total current does not exceed nominal current for the regulator.



RDT



RET

Technical data of RDT regulators

Type	Max. current, A	Figure*	Protection level	Protection device at the feeding line
RDT-2KTG	2	A	IP 54	4A
RDT-4KT	4	B	IP21	8A
RDT-7KT	7	B	IP21	16A
RTRD 14E	14	C	IP21	25A

Nominal input voltage: 3 ~ 400 V, 50/60 Hz

Output voltage can be set with a 5–step switch (95V-145V-190V-240V-400V).

Maximum permissible temperature of the environment: +40C°

* See the RD regulators

Technical data of RET regulators

Type	Max. current, A	Figure*	Protection level	Protection device at the feeding line
RET 2KTG	2	A	IP 54	4 A
RET 6KTG	6	A	IP54	12 A

Nominal voltage: 1 ~ 230 V, 50/60 Hz

Maximal permissible temperature of the environment: +40C°

Output voltage is changed by a 5–step switch (65V-110V-135V-170V-230V).

** See RE regulators

ELECTRONIC RPM REGULATOR FC 2

General information

Electronic revolutions regulators of FC 2 type are meant for delivery changing of ventilators equipped with one-phase asynchronous motor. The number of revolutions is adjusted by changing the voltage supplied to the motor from alternating current network.

Device casing is made of plastic and intended for mounting on a DIN rail.



Dimension-types and basic technical information

Nominal voltage	220 V, 50 Hz
Maximal current	2,3 A.
Protection class	IP20
Dimensions (WxDxH)	87,5x35,5x58,5 mm
Allowable environment temperature	+1...+40° C

No opportunity to link up ventilator thermocontacts.

FREQUENCY RPM REGULATORS TYPE SINUS N AND SINUS M

General information

Frequency rpm regulators SINUS are used to control the three-phase ventilators productivity and protection. Regulators have a smooth rpm motor speed control due to the change of output frequency and voltage.

Technical characteristics

Regulatoriem ir:

- Regulators consist of:
- built-in control console;
 - PID regulator;
 - max. output frequency – 400 Hz;
 - IP 20 design;
 - input filter EMC;
 - external control ports;
 - analogous port 0 – 10V;
 - relay port;
 - analogous port 0 – 10V.

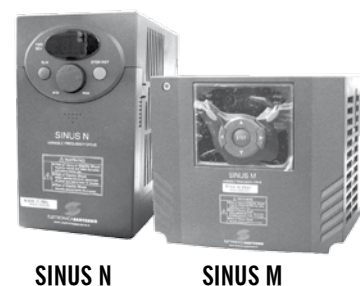

SINUS N

SINUS M

Indication	Input voltage	Output voltage	Ventilator motor capacity, kW	Dimensions (WxDxH), mm	Weight, kg
SINUS N 0002 2S XBK2	230V	3x230V	0,75 – 1,1	79x143x143	1,2
SINUS N 0005 2S XBK2	230V	3x230V	2,2 - 3	156x143x143	2,4
SINUS M 0007 4T BA2K2	3x400V	3x400V	4	140x128x155	1,89
SINUS M 0011 4T BA2K2	3x400V	3x400V	5,5	180x220x170	3,66

PROTECTIVE RELAYS STDT16, S-ET10

General information

Protective relays STDT16 and S-ET10 are used for the start-up and protection of three- and one-phase motors fitted with the separate chain of thermocontacts. When disconnecting the thermocontacts the device automatically shuts the ventilator off. Additionally, the relay is fitted with the short circuit protection. After device is activated the repeated start-up is possible after electric motor cooling-down.

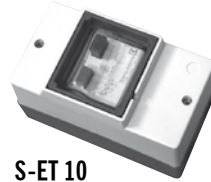
STDT16

S-ET 10

Technical characteristics

Safety fuse (STDT 16)		80 A
Maximal section of cable	feeding auxiliary switch and thermocontacts	4 mm ² 2,5 mm ²
Power supply	STDT 16 S-ET 10	380 V 220 V
Maximal current	STDT 16 S-ET 10	16 A 10 A
Permissible environment temperature		-25 +40° C

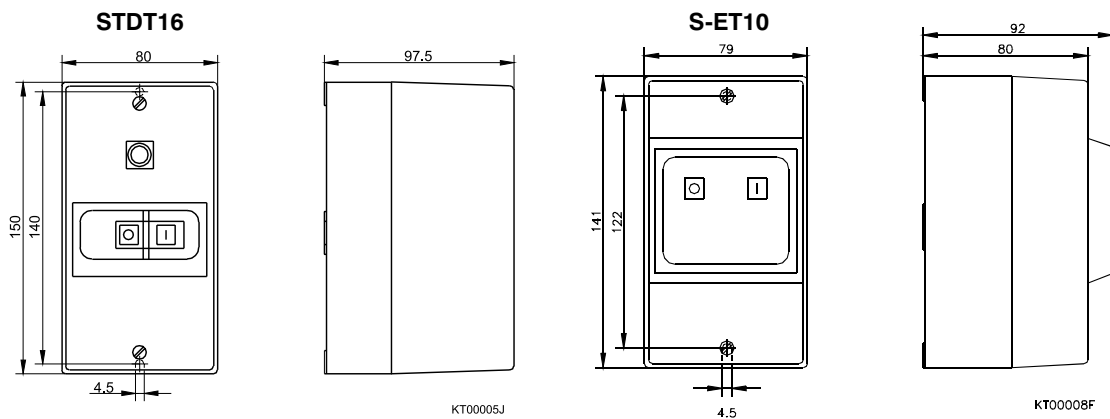
Dimensions



ENGINE START-UP AND PROTECTION DEVICE UZ-V...

General information

These devices are meant for switching on/off and protection of three-phase ventilators (380 V) without thermocontacts equipped. The device is an adjusted current-limiting automatic device in a plastic box with a transparent flat lid. The box has IP 54 protection class (with a closed lid).



Types of devices

Name	Ventilatora Power, kW	Piesłędzanie ventilatori
UZ-V0,55	0,25 - 0,55	LVP 40-20/18.2D, LVP 50-25/20.2D, LVP 50-25/22.2D, LVP 50-30/22.2D
UZ-V1,1	0,75 - 1,1	LVP 50-30/25.2D, LVP 60-30/25.2D, LVP 60-30/28.2D, LVP 60-35/28.2D
UZ-V1,5	1,5	LVP 60-35/31.2D, LVP 70-40/31.2DM
UZ-V2,2	2,2	LVP 70-40/31.2D
UZ-V4	3 - 4	LVP 70-40/35.2D, LVP 80-50/35.2D, LVP 80-50/40.4D, LVP 90-50/35.2D, LVP 90-50/40.4D, LVP 100-50/45.4D
UZ-V5,5	5,5	LVP 90-50/40.2D, LVP 100-50/40.2D

VENTILATORS CONTROL PANEL PU-V...

Application

Ventilators control panels type PU-V... are used for the start-up and protection of the three-phase ventilators (380V) not fitted with thermocontacts (or thermistors). Protection of ventilators from overload is implemented by use of current-resisting automatic units. Additionally the panels are fitted with the short circuit protection.



Bloku tipi

Name	Ventilator power, kW	Ventilators
PU-V0,55	0,25 - 0,55	LVP 40-20/18-2D, LVP 50-25/20-2D, LVP 50-25/22-2D, LVP 50-30/22-2D
PU-V1,1	0,75 - 1,1	LVP 50-30/25-2D, LVP 60-30/25-2D, LVP 60-30/28-2D, LVP 60-35/28-2D
PU-V1,5	1,5	LVP 60-35/31-2D, LVP 70-40/31-2DM
PU-V2,2	2,2	LVP 70-40/31-2D
PU-V4	3 - 4	LVP 70-40/35-2D, LVP 80-50/35-2D, LVP 80-50/40-4D, LVP 90-50/35-2D, LVP 90-50/40-4D, LVP 100-50/45-4D
PU-V5,5	5,5	LVP 90-50/40-2D, LVP 100-50/40-2D

Operation conditions

Panes PU-V... can be used in dry, clean premises without dust and chemical particles. Permissible temperature of the environment is +5° to +40° C.

Construction

Boxes have plastic case with transparent lid. Dimensions of boxes are 275x365x140 mm. The unit protection level is IP 65 when the lid is closed and IP 40 when the lid is opened.

The power part of the unit consists of knife-switches, protective automatic units, magnetic starters and clamps.

Control and protection functions are provided by relay logic circuits.

Standard functions

Control panes PU-V are used to start-up, shutdown and protect the connected ventilators. The panes have the following functions:

- manual start-up and shutdown;
- external start-up and shutdown by non-potential contact;
- connection and protection of ventilator without thermocontacts;
- control of air choke servo-motor (230 volts);
- relay alarm signal.

CONTROL UNITS TYPE PUAT

Application

Control unit PUAT is a compact device, which combines power switchboard and automatics system. These control units are designed for the control over supply or supply-extract ventilation installations and have two quantized outputs.

Application of programmed electronic thermostat allows to achieve stable and reliable functioning of the unit, and conception of the construction allows to use it with almost any ventilation equipment.

Standard PUAT unit is designed for control over ventilation installation with the electric heating only.



Operation conditions

Control units can be used in dry, clean premises without dust and chemical particles. Allowable temperature of the environment – +5° to +40° C.

Indication

The scheme below shows the key to a type indication of control units

PUAT-E9-31-S-T

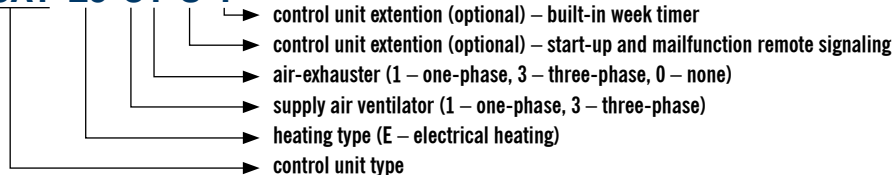

Indication	Installment scheme	Ventilators (phases)	
		Air supply	Air exhaust
Radiator capacity up to 3кВт			
PUAT-E3-10	A	1~220 (till 2A)	
PUAT-E3-11	B	1~220 (till 2A)	1~220 (till 2A)
Radiator capacity up to 9кВт			
PUAT-E9-30	A	3~380	-
PUAT-E9-10	A	1~220	-
PUAT-E9-31	B	3~380	1~220
		1~220	3~380
PUAT-E9-33	B	3~380	3~380
PUAT-E9-11	B	1~220	1~220
Radiator capacity up to 15кВт			
PUAT-E15-30	A	3~380	-
PUAT-E15-10	A	1~220	-
PUAT-E15-31	B	3~380	1~220
		1~220	3~380
PUAT-E15-33	B	3~380	3~380
PUAT-E15-11	B	1~220	1~220
Radiator capacity up to 22,5 кВт			
PUAT-E22-30	A	3~380	-
PUAT-E22-10	A	1~220	-
PUAT-E22-31	B	3~380	1~220
		1~220	3~380
PUAT-E22-33	B	3~380	3~380
PUAT-E22-11	B	1~220	1~220

Indication	Installment scheme	Ventilators (phases)	
		Air supply	Air exhaust
Radiator capacity up to 30 kBt			
PUAT-E30-30	A	3~380	-
PUAT-E30-10	A	1~220	-
PUAT-E30-31	B	3~380	1~220
		1~220	3~380
PUAT-E30-33	B	3~380	3~380
PUAT-E30-11	B	1~220	1~220
Radiator capacity up to 45 kBt			
PUAT-E45-30	A	3~380	-
PUAT-E45-10	A	1~220	-
PUAT-E45-31	B	3~380	1~220
		1~220	3~380
PUAT-E45-33	B	3~380	3~380
PUAT-E45-11	B	1~220	1~220
Radiator capacity up to 60 kBt			
PUAT-E60-30	A	3~380	-
PUAT-E60-10	A	1~220	-
PUAT-E60-31	B	3~380	1~220
		1~220	3~380
PUAT-E60-33	B	3~380	3~380
PUAT-E60-11	B	1~220	1~220

Typical schemes

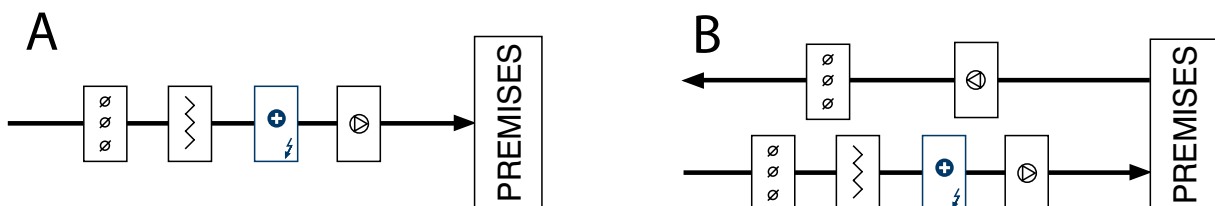

Construction

Boxes have a plastic case 280x570x140 mm with a transparent lid.

The unit protection level is IP 65 with the closed lid and IP 40 with the open lid.

For the systems with electric heater of 45 and 60 kW additionally to the main unit a metallic power switchboard 600x500x210 mm with a protection level IP 55 is made.

Application of a transformer of 24 volts capacity in power supply chains allows to reduce the probability of the electroshock damage caused to the personnel in charge of the equipment start-up and maintenance.

In the control units standard (by default) and extended (additional) functions are provided.

Standard functions

- manual start-up and shutdown from the control unit;
- external start-up and shutdown by a non-potential contact
- protection and control of ventilators with thermocontacts of up to 5 kW;
- protection and control of a single-stage electric heater (for radiators of up to 9 kW inclusive);
- protection and control of a double-stage electric heater (for radiators of over 9 kW);
- falling delay of the fresh air ventilator;
- control of servo-motors of air chokes (of 24 or 230 volts power supply);
- discrete supply air temperature adjustment;
- ventilator differential pressure monitoring;
- filter clogging up monitoring;
- shutoff on fire alarm activation.

Extended functions

Name	Funkcijas
A1; A1,6; A2,5; A4; A6,3	Ventilator connection without thermocontacts. Note: a digit before the "A" shows the number of ventilator that needs to be extended (1 – supply air, 2 – exhaust, 3 – auxiliary). For example, 1A16 extension applies to air supply ventilator, at max. current between 10 and 16 A.
A10; A16	
S	Start-up and malfunction remote signalling
T	Built-in week timer (except PUAT-E3)
L	FC electronic rotation regulator (220 V, up to 2.3 A) (except for PUAT-E3)

Connection of sensors

Temperature sensors which are connected to the control units should have thermosensitive element characteristic NTC 12 kOm, and pressure sensors – relay outlet.

CONTROL UNITS TYPE PUA 210

Application

Control unit PUA 210 is a compact device, which combines power switchboard and automatics system. These units are designed for control over supply or supply-extract ventilation installations and have one analog output for actuating mechanisms control.

Application of the controller manufactured by the company SIEMENS allows to achieve stable and reliable functioning of the unit, and conception of the construction allows to apply it with almost any ventilation equipment.

Standard unit PUA 210 is designed for the control over ventilation installation with water heating only.



Operation conditions

Control units can be used in dry, clean premises without dust and chemical particles. Allowable temperature of the environment – +5° to +40° C.

Indication

The scheme below shows the key to a type indication of control units.

PUA 210-W-31-1-T

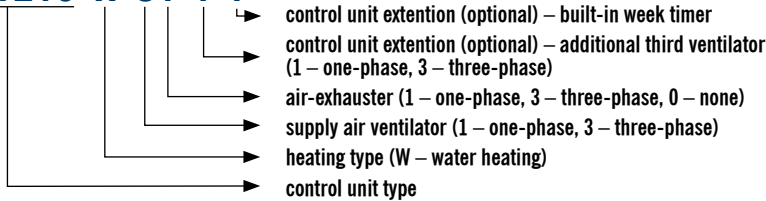

Indication	Installment scheme	Ventilators (phases)	
		Air supply	Air supply
PUA210-W-30	A	3~380	-
PUA210-W-10	A	1~220	-
PUA210-W-31	B	3~380	1~220
		1~220	3~380
PUA210-W-33	B	3~380	3~380
PUA210-W-11	B	1~220	1~220

Typical schemes

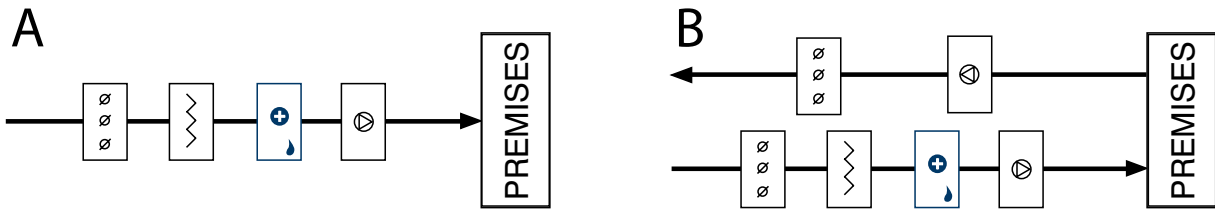

The boxes have plastic cases with a transparent lid and are manufactured in two dimension-types: 380x570x140 mm or 275x570x140 mm. The unit protection level is IP 65 with closed lid and IP 40 with open lid. Application of a transformer of 24 volts capacity in power supply chains allows reducing of electroshock damage probability caused to personnel in charge of equipment start-up and maintenance.

Control units have standard (by default) and extended (additional) functions.

Standard functions

- manual start-up and shutdown from the control unit;
- external start-up and shutdown by non-potential contact;
- protection and control of ventilators with thermocontacts of up to 5 kW;
- protection and control of a monophasic circulation pump;
- control over servo-motors of air chokes (of 24 or 230 volts power supply);
- proportionally – supply air temperature or indoor temperature integral adjustment (cascaded adjustment);
- control over servo-motor of the heating water valve;
- protection from water heater freezing by air (capillary thermostat);
- active anti-freeze protection and preset backdriving water temperature maintenance in a standby mode (if water sensor installed). Note - for the units type PUA 210, contrary to other units, system shutoff by water sensor does not happen;
- ventilator pressure differential monitoring;
- filter clogging up monitoring;
- manual heating water pump start-up;
- shutoff on fire alarm activation.

Extended functions

Name	Functions
1 or 3	Third ventilator connection (1 – one-phase, 3 – three-phase)
A1; A1,6; A2,5; A4; A6,3	Ventilator connection without thermocontacts. Note: a digit before the "A" shows the number of ventilator that needs to be extended (1 – supply air, 2 – exhaust, 3 – auxiliary). For example, 1A16 extension applies to air supply ventilator, at max. current between 10 and 16 A.
A10; A16	
S	Start-up and malfunction remote signalling
T	Built-in week timer
L	FC electronic rotation regulator (220 V, up to 2.3 A)

Connection of sensors

Temperature sensors which are connected to the control units should have thermosensitive element characteristic LG Ni1000 (Ni1000 TK5000), and pressure sensors and thermostat – relay outlet.

CONTROL UNITS TYPE PUA 222

Application

Control unit PUA 222 is a compact device, which combines power switchboard and automatics system. These units are designed for supply or supply-extract ventilation installations control and have two analog outputs and two quantized outputs for actuating mechanisms control. Application of the controller manufactured by the company SIEMENS allows to achieve stable and reliable functioning of the unit, and conception of the construction allows to apply it with almost any ventilation equipment.

Standard unit PUA 222 is designed for ventilation installation control with water heating and water cooling or electric heating and water cooling. When using the extension F it is possible to control a two-contour compressor-condensation unit.



Operation conditions

Control units can be used in dry, clean premises without dust and chemical particles. Allowable temperature of the environment – +5° to +40° C.

Indication

The scheme below shows the key to a type indication of control units.

PUA 222-W-31-1-T

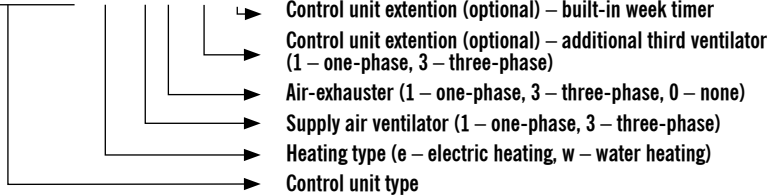

Control units for air supply sets with water air heaters and water coolers			
Indication	Installment scheme	Ventilators (phases)	
		Air supply	Air supply
PUA222-W-30	A	3~380	-
PUA222-W-10	A	1~220	-
PUA222-W-31	B	3~380	1~220
		1~220	3~380
PUA222-W-33	B	3~380	3~380
PUA222-W-11	B	1~220	1~220

Control units for air supply sets with electric radiators and water coolers			
Indication	Installment scheme	Ventilators (phases)	
		Air supply	Air supply
Radiator capacity up to 9кВт			
PUA 222-E9-30	C	3~380	-
PUA 222-E9-10	C	1~220	-
PUA 222-E9-31	D	3~380	1~220
		1~220	3~380
PUA 222-E9-33	D	3~380	3~380
PUA 222-E9-11	D	1~220	1~220
Radiator capacity up to 15кВт			
PUA 222-E15-30	C	3~380	-
PUA 222-E15-10	C	1~220	-
PUA 222-E15-31	D	3~380	1~220
		1~220	3~380
PUA 222-E15-33	D	3~380	3~380
PUA 222-E15-11	D	1~220	1~220
Radiator capacity up to 22,5 кВт			
PUA 222-E22-30	C	3~380	-
PUA 222-E22-10	C	1~220	-
PUA 222-E22-31	D	3~380	1~220
		1~220	3~380
PUA 222-E22-33	D	3~380	3~380
PUA 222-E22-11	D	1~220	1~220

Indication	Installment scheme	Ventilators (phases)	
		Air supply	Air supply
Radiator capacity up to 30 kBt			
PUA 222-E30-30	C	3~380	-
PUA 222-E30-10	C	1~220	-
PUA 222-E30-31	D	3~380	1~220
		1~220	3~380
PUA 222-E30-33	D	3~380	3~380
PUA 222-E30-11	D	1~220	1~220
Radiator capacity up to 45 kBt			
PUA 222-E45-30	C	3~380	-
PUA 222-E45-10	C	1~220	-
PUA 222-E45-31	D	3~380	1~220
		1~220	3~380
PUA 222-E45-33	D	3~380	3~380
PUA 222-E45-11	D	1~220	1~220
Radiator capacity up to 60 kBt			
PUA 222-E60-30	C	3~380	-
PUA 222-E60-10	C	1~220	-
PUA 222-E60-31	D	3~380	1~220
		1~220	3~380
PUA 222-E60-33	D	3~380	3~380
PUA 222-E60-11	D	1~220	1~220

Typical schemes

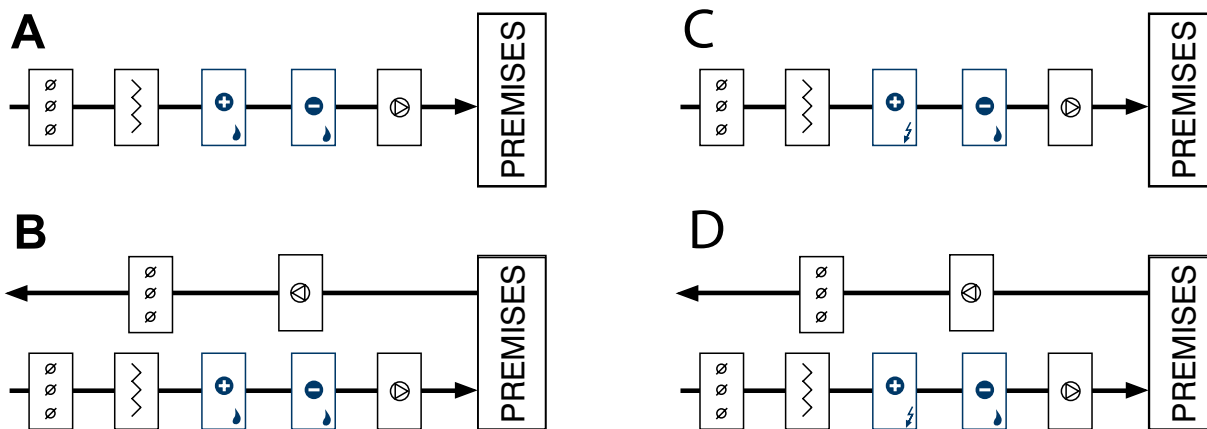

Construction

Boxes have plastic cases with a transparent lid and are manufactured in two dimension-types: 380x570x140 mm or 275x570x140 mm. The unit protection level is IP 65 with closed lid and IP 40 with open lid. For the systems with electric heater of 45 and 60 kW capacity a metallic power switchboard 600x500x210 mm with a protection degree IP 55 is made in addition to the main unit. Application of a transformer of 24 volts in the power supply chains allows to reduce the probability of electroshock damage caused to personnel in charge of the equipment start-up and maintenance. Control units are provided with standard (by default) and extended (additional) functions.

Standard functions

- manual start-up and shutdown from the control unit;
- external start-up and shutdown by non-potential contact;
- protection and control of ventilators with thermocontacts of up to 5 kW capacity;
- protection and control of a monophasic circulation pump (for systems with water heating);
- protection and control of a single-stage electric heater (for systems with electric heating and radiators of up to 9 kW capacity inclusive);
- protection and control of a double-stage electric heater (for systems with electric heating and radiators of over 9 kW capacity);
- air supply ventilator shutdown delay (for systems with electric heating)
- control over servo-motors of air chokes (of 24 or 230 volts power supply);
- proportionally –supply air temperature or indoor temperature integral adjustment (cascade adjustment);
- heating water valve servo-motor control (for systems with water heating);
- water cooler valve servo-motor control;
- protection from water heater freezing by air (capillary thermostat, for systems with water heating);
- active anti-freeze protection and preset backdriving water temperature maintenance in a standby mode (for systems with water heating);
- ventilator pressure differential monitoring;
- filter clogging up monitoring;
- heating water pump automatic start-up according to outdoor temperature;
- shutoff on fire alarm activation.

Extended functions

Name	Functions
1 or 3	Third ventilator connection (1 – one-phase, 3 – three-phase) (for units of PUA...-W type only)
A1; A1,6; A2,5; A4; A6,3	Ventilator connection without thermocontacts. Note: a digit before the "A" shows the number of ventilator that needs to be extended (1 – supply air, 2 – exhaust, 3 – auxiliary). For example, 1A16 extension applies to air supply ventilator, at max. current between 10 and 16 A.
A10; A16	
F	2-circuit compressor-condensate unit control
S	Start-up and malfunction remote signalling
T	Built-in week timer
L	FC electronic rotation regulator (220 V, up to 2.3 A)

Connection of sensors

Temperature sensors which are connected to the control units should have thermosensitive element characteristic LG Ni1000 (Ni1000 TK5000), and pressure sensors and thermostat – relay outlet.

CONTROL UNITS TYPE PUA 236

Application

Control unit PUA 236 is a compact device, which combines power switchboard and automatics system. These units are designed for supply or supply-extract ventilation installations control and have three analog outputs and six quantized outputs for the control over actuating mechanisms. Application of the controller manufactured by the SIEMENS company allows to achieve stable and reliable functioning of the unit, and conception of the construction allows to apply it with almost any ventilation equipment.

Standard PUA 236 unit is designed to control ventilation installation with water heating and water/freon cooling or electric heating and water/freon cooling.



Operation conditions

Control units can be used in dry, clean premises without dust and chemical particles. Allowable temperature of the environment – +5° to +40° C.

Indication

The scheme below shows the key to a type indication of control units.

PUA 236-W-31-1-T

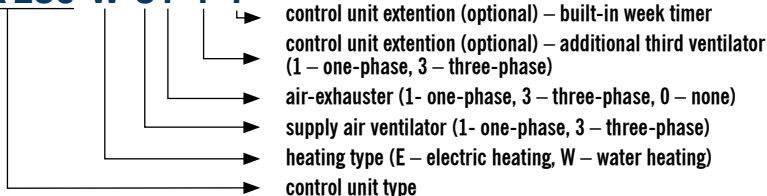

Control units for air supply sets with water air heaters and water (freon) coolers

Indication	Installment scheme	Ventilators (phases)	
		Air supply	Air supply
PUA236-W-30	A	3~380	-
PUA236-W-10	A	1~220	-
PUA236-W-31	B	3~380	1~220
		1~220	3~380
PUA236-W-33	B	3~380	3~380
PUA236-W-11	B	1~220	1~220

Control units for air supply sets with electric radiators and water (freon) coolers

Indication	Installment scheme	Ventilators (phases)	
		Air supply	Air supply
Radiator capacity up to 9кВт			
PUA 236-E9-30	C	3~380	-
PUA 236-E9-10	C	1~220	-
PUA 236-E9-31	D	3~380	1~220
		1~220	3~380
PUA 236-E9-33	D	3~380	3~380
PUA 236-E9-11	D	1~220	1~220
Radiator capacity up to 15кВт			
PUA 236-E15-30	C	3~380	-
PUA 236-E15-10	C	1~220	-
PUA 236-E15-31	D	3~380	1~220
		1~220	3~380
PUA 236-E15-33	D	3~380	3~380
PUA 236-E15-11	D	1~220	1~220
Radiator capacity up to 22,5 кВт			
PUA 236-E22-30	C	3~380	-
PUA 236-E22-10	C	1~220	-
PUA 236-E22-31	D	3~380	1~220
		1~220	3~380
PUA 236-E22-33	D	3~380	3~380
PUA 236-E22-11	D	1~220	1~220

Indication	Installment scheme	Ventilators (phases)	
		Air supply	Air supply
Radiator capacity up to 30 kBT			
PUA 236-E30-30	C	3~380	-
PUA 236-E30-10	C	1~220	-
PUA 236-E30-31	D	3~380	1~220
		1~220	3~380
PUA 236-E30-33	D	3~380	3~380
PUA 236-E30-11	D	1~220	1~220
Radiator capacity up to 45 kBT			
PUA 236-E45-30	C	3~380	-
PUA 236-E45-10	C	1~220	-
PUA 236-E45-31	D	3~380	1~220
		1~220	3~380
PUA 236-E45-33	D	3~380	3~380
PUA 236-E45-11	D	1~220	1~220
Radiator capacity up to 60 kBT			
PUA 236-E60-30	C	3~380	-
PUA 236-E60-10	C	1~220	-
PUA 236-E60-31	D	3~380	1~220
		1~220	3~380
PUA 236-E60-33	D	3~380	3~380
PUA 236-E60-11	D	1~220	1~220

Typical schemes

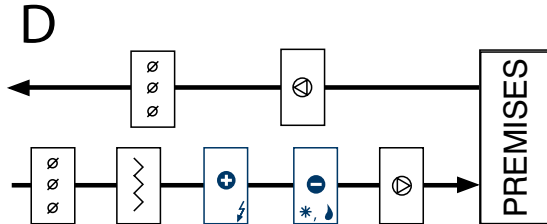
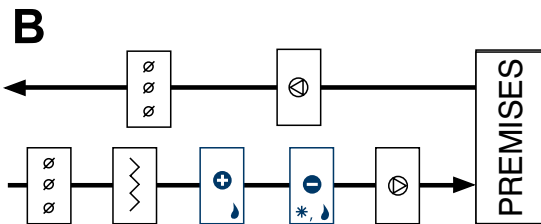
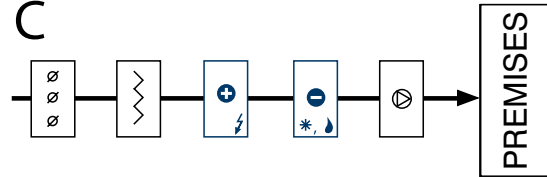
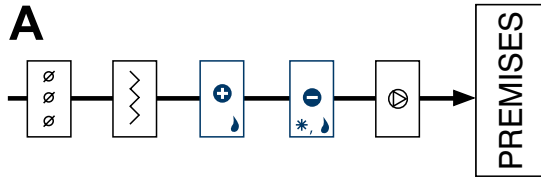

Construction

Boxes have plastic cases with a transparent lid and dimensions 380x570x140 mm. The unit protection level is IP 65 with closed lid and IP 40 with open lid. For the systems with electric heater of 45 and 60 kW capacity a metallic power switchboard 600x500x210 mm with a protection degree IP 55 is made in addition to the main unit. Application of a transformer of 24 volts in the power supply chains allows to reduce the probability of electroshock damage caused to personnel in charge of the equipment start-up and maintenance.

Control units are provided with standard (by default) and extended (additional) functions.

Standard functions

- manual start-up and shutdown from the control unit;
- external start-up and shutdown by non-potential contact;
- protection and control of ventilators with thermocontacts of up to 5 kW capacity;
- protection and control of a monophase circulation pump (for systems with water heating);
- protection and control of a single-stage electric heater (for systems with electric heating and radiators of up to 9 kW capacity inclusive);
- protection and control of a double-stage electric heater (for systems with electric heating and radiators of over 9 kW capacity);
- air supply ventilator shutdown delay (for systems with electric heating)
- control over servo-motors of air chokes (of 24 or 230 volts power supply);
- proportionally – supply air temperature or indoor temperature integral adjustment (cascade adjustment);
- heating water valve servo-motor control (for systems with water heating);
- two-stage control of compressorcondensate unit (dry contact, freon cooling);
- water cooler valve servo-motor control (for water cooling);
- protection from water heater freezing by air (capillary thermostat, for systems with water heating);
- active anti-freezing protection and preset backdriving water temperature maintenance in a standby mode (for systems with water heating);
- ventilator pressure differential monitoring;
- filter clogging up monitoring;
- heating water pump automatic start-up according to outdoor temperature;
- shutoff on fire alarm activation.

Extended functions

Name	Funkcijas
1 or 3	Third ventilator connection (1 – one-phase, 3 – three-phase) (for units of PUA...-W type only)
A1; A1,6; A2,5; A4; A6,3	Ventilator connection without thermocontacts. Note: a digit before the "A" shows the number of ventilator that needs to be extended (1 – supply air, 2 – exhaust, 3 – auxiliary). For example, 1A16 extension applies to air supply ventilator, at max. current between 10 and 16 A.
A10; A16	
S	Start-up and malfunction remote signalling
T	Built-in week timer
L	FC electronic rotation regulator (220 V, up to 2.3 A)

Connection of sensors

Temperature sensors which are connected to the control units should have thermosensitive element characteristic LG Ni1000 (Ni1000 TK5000), and pressure sensors and thermostat – relay outlet.

TEMPERATURE SENSORS STK-...

General information

Resistive channel temperature sensor is installed into the airway and is used to measure the air stream temperature. An assembly flange with retention screw is supplied for attaching the sensor on the inside of the airway. The terminal block of the sensor is made of shockproof plastic. Responsive resistive element is placed either into the stainless steel case (STK-1, STK-2) or into the slender column (STK-1M, STK-2M).



Technical characteristics

Measurement range	-30 ... +150°C
Measurement element for STK-1, STK-1M sensor	Ni 1000 TK5000
Measurement element for STK-2, STK-2M sensor	NTC 12 kΩm
Connection type	2-wire clip
Measured current	max. 1 mA
Case	Rectangular, plastic, white RAL9010
Sensor rod length (NL) STK-...	200 mm
Sensor rod length (NL) STK-...M	100 mm
Clip box	Rectangular, plastic, white RAL 9010
Wire cross-section	0,14 - 1,5 mm ²
Insulation resistance	> 100 MΩm, at 20° C (500 V direct current)
Relative humidity	< 95%
Protection class	IP65

Dimensions

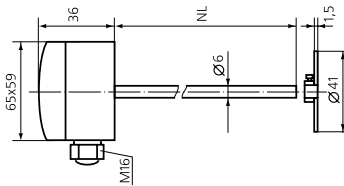

ROOM TEMPERATURE SENSOR STP

General information

Room temperature sensor STP is used to measure indoor air temperature. The case is made of a shockproof plastic and is wall-mounted.



Technical characteristics

Measurement range	-30 ... +90° C
Measurement element	Ni 1000 TK5000
Connection type	2-wire clip
Measured current	max. 1 mA
Mounting	With screws on a flat surface
Case	Rectangular, plastic, white RAL 9010
Electrical connection	0,14 - 1,5 mm ² , through screw clamp, on a safely small voltage, direct current of max. 24 V
Relative humidity	< 95%, without condensate
Protection class	IP30

Dimensions

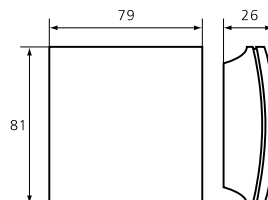

OUTDOOR AIR TEMPERATURE SENSOR STN

General information

Outdoor air temperature sensor STN is used to measure outside air temperature. The case is made of shockproof plastic and is wall-mounted.



Technical characteristics

Measurement range	-50... +90° C
Measurement element	Ni 1000 TK5000
Connection type	2-wire clip
Measured current	max. 1 mA
Case	Rectangular, plastic, white RAL 9010
Cable mounting	Screw compressive gland PG11
Wire cross-section	0,14 – 1,5 mm ²
Insulation resistance	> 100 MOm, at 20° C (500 V direct current)
Mounting	With screws on a flat surface
Protection class	IP65

Dimensions

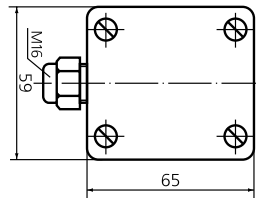

IMMERSIBLE WATER TEMPERATURE SENSOR VSP

General information

Immersible water temperature sensor VSP is used to measure backdriving water temperature in radiators. Sensitive element is located in the impermeable stainless steel rod. The sensor is screwed directly into water collector of heat exchanger. The sensor is an element of heat exchanger protection from freezing by backdriving water temperature.

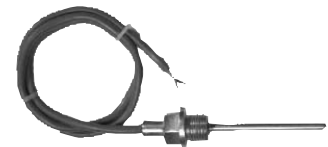

Technical characteristics

Measurement range	-50... +180° C with silicone cable (-35... +105° C with PVC cable)
Measurement element	Ni 1000 TK5000
Connection type	2-wire clip
Mounting	G1/2" thread
Measured current	approx. 1 mA
Cable length (KL)	1,5 m
Cylinder material	Stainless steel
Connection cable	PVH (up to +105° C); silicone (up to +180° C)
Screw part length (EL)	(EL) 100 mm (50 mm)
Relative humidity	< 95%
Protection class	IP54

Dimensions

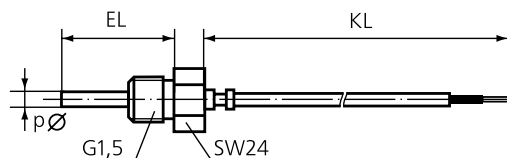

SUPERIMPOSED TEMPERATURE SENSOR VSN

General information

Superimposed temperature sensor VSN is used to measure backdriving water temperature in radiators. Contact surface of the sensor is pressed to the pipe-line by a steel clamp. Sensor is an element of heat exchanger protection from freezing by the backdriving water temperature.



Technical characteristics

Measurement range	-30... +110° C
Measurement element	Ni1000 TK5000
Connection type	2-wire clip
Measured current	approx. 1 mA
Mounting	Screw clamp
Clamp dimensions	d = 13... 92 mm (1/4... 3"), L = 300 mm
Case	Rectangular, plastic, white RAL 9010
Wire cross-section	0,14 – 1,5 mm ²
Insulation resistance	> 100 MOm, at 20° C (500 V direct current)
Relative humidity	< 95%
Protection class	IP54

Dimensions

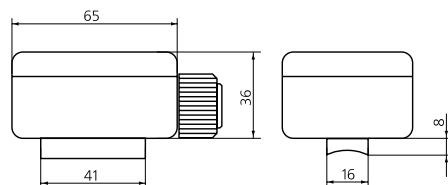

CAPILLARY THERMOSTAT AZT-...

General information

Capillary thermostat AZT-... is used to control air temperature after water radiators. It is an element of heat exchanger protection from freezing by supply air temperature.

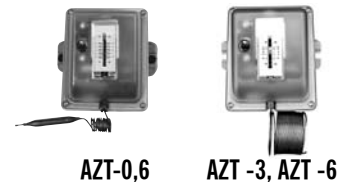

Technical characteristics

Switching current	15 (8) A; 24... 250V alternating current
Hysteresys	1 K
Switching type	Closed microswitcher with a throwable contact
Case	plastic, color gray, with transparent lid made of plexiglass
Environment temperature	-15... +55° C
Operating range	-10... +12° C
Capillar length	AZT-0,6 – 0,6 m, AZT-3 – 3 m, AZT-6 – 6 m
Mounting	On a vertical flat surface, providing access to adjustment screw
Sensing element	Made of copper, active along the full length
Protection class	IP 54
Operation principle	When temperature drops below the preset value red and white contacts open, but red and blue seal in

Dimensions

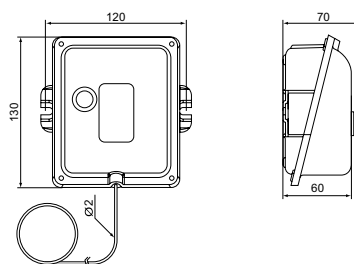

DIFFERENTIAL PRESSURE SENSORS DPD...

General information

Differential pressure sensor DPD-... is used to measure pressure differential on different elements of ventilation systems. In particular, it serves for control of filter clogging, determination of ventilator belt break.



Technical characteristics

Switching current	1,5 (0,4) A; 14...250V alternating current, 4 (0,7) A, 30 V direct current
Switching type	Closed microswitcher with a throwable contact
Case	Mounting base made of PVC with transparent plastic lid
Environment temperature	-20... +85° C
Operating range	DPD-2 20...500 Pa, DPD-50...500 Pa, DPD-10 100...1000 Pa
Max. permissible pressure	5000 Pa
Membrane material	silicone
Protection class	IP 54
Pressure fitting connection	P1 fitting for pressure, P2 – for exhaustion
Operation principle	Contacts 3-1 open when pressure difference reaches the preset value, at the same time contacts 3-2 seal in

Dimensions

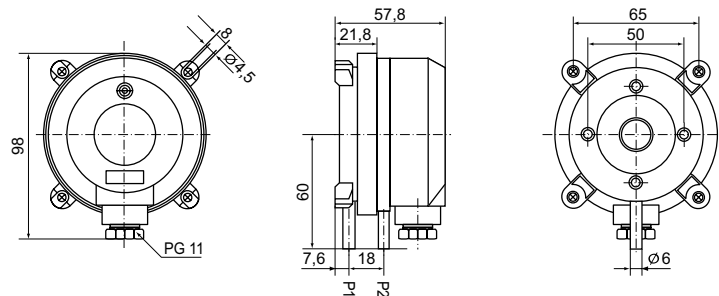

ELECTRIC DRIVES OF AIR CHOKES

General information

BELIMO rotor type electric drives are used to control the position of air chokes in ventilation and conditioning systems. It is possible to adjust angular deflection of the electric drive with the help of the fitted limit stop.



Technical characteristics

Type	LM 24A	LM 24A-SR	LM 230A	LF 24	LF 230
Control	2,3-pos	0 - 10 V	2,3-pos	2-pos	2-pos
Voltage	24 V AC/DC	24 V AC/DC	230 V AC	24 V AC/DC	230 V AC
Capacity, VA	2	2	4	7	7
Torque	5 Hm	5 Hm	5 Hm	4 Hm	4 Hm
Approx. max. area of a choke, m ²	1	1	1	0,8	0,8
Deflection time, s	150	150	150	Open 75	Open 75
Return spring				Close 30	Close 30
Max. deflection angle, degrees	No	No	No	Yes	Yes
Case protection level	95	95	95	95	95
Operational temperature, C	IP54	IP54	IP54	IP54	IP54
Mass, kg	-30... +50°	-30... +50°	-30... +50°	-30... +50°	-30... +50°
Dimensions (WxDxH),	0,5	0,5	0,6	1,4	1,55
Rod diagonal size, mm	66x61x157	66x61x157	66x61x157	98x82x181	98x82x181
Stieņa diagonāles izmērs, mm	6...20	6...20	6...20	8...16	8...16

THREE-WAY VALVES VXP 45.10-...

General information

Are used in ventilation, conditioning and heating systems as mixing or separation valves.
 Maximal operating pressure: 1,6 MPa.
 Case material: bronze.

Operating environment:

- Cold water
- Hot water
- Water with antifreeze (up to 50 %)
- Heat carrier temperature + 2... + 110 °C



Types

Type	Diameter, mm	Nominal consumption Kvs	Maximum permitted pressure loss at dP valve, kPa	
			Mixing	Separation
VXP 45.10-0,25	10	0,25	600	200
VXP 45.10-0,4	10	0,4	600	200

Equipment combinations

Valve type	Rod stroke, mm	Drive	Fittings
VXP 45.10-0,25	5,5	SSB 61	ALG 13
VXP 45.10-0,4			

Dimensions and weight

DN, mm	D, thread	H1, mm	H2, mm	L1, mm	L2, mm	L3, mm	B, mm	Weight, kg
10	G1/2B	44,9	54	60	30	30	29	0,28

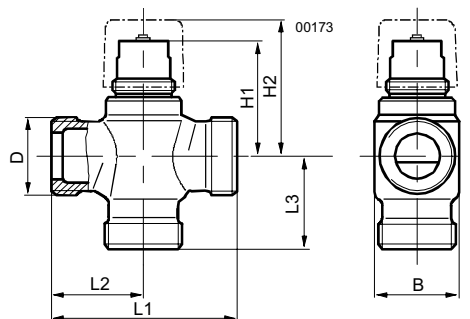
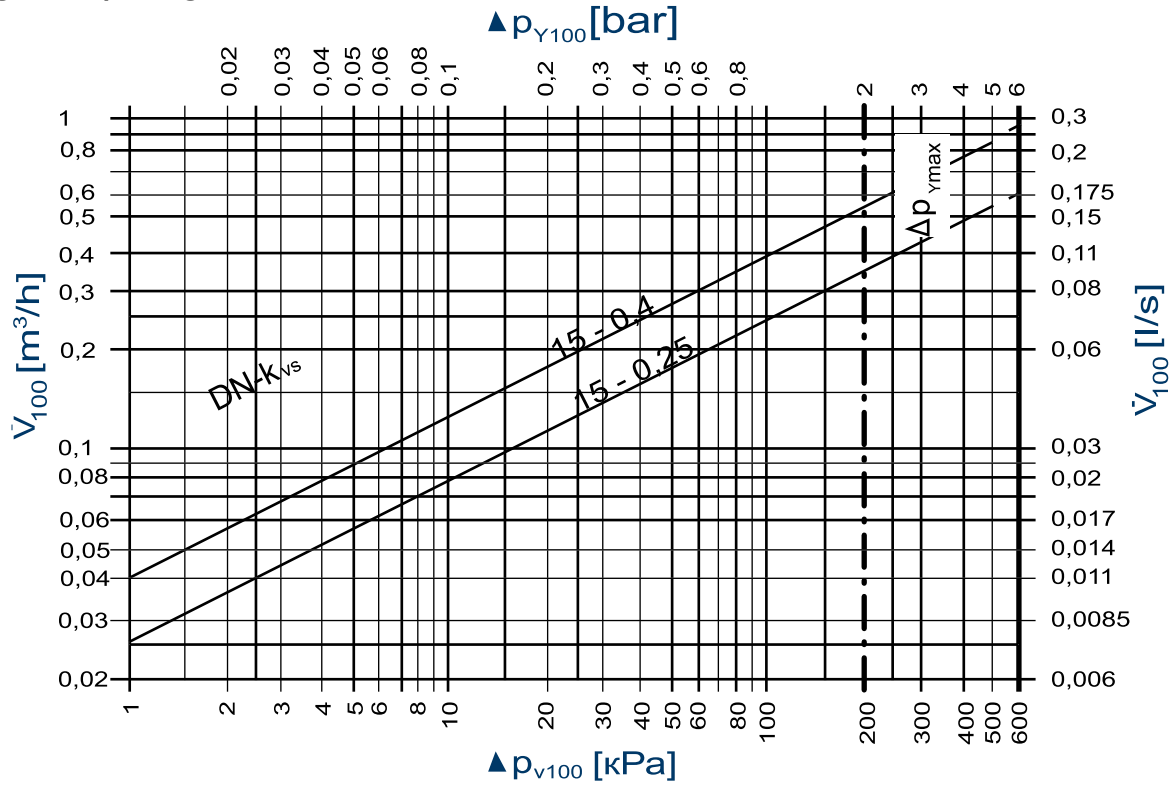

Diagram of operating characteristics



100 kPa = 1 bar ~ 10 mWG

1 m³/h = 0,278 kg/sec water 20° C

— = Δp_{vmax} = Maximal value of pressure loss in a controlling stroke of a mixing valve II-I actual for common stroke level

- · - = Δp_{vmax} = Maximal value of pressure loss in a controlling stroke of a distributional valve II-I actual for common stroke level.

Δp_{v100} = Pressure loss at a full-opened valve (drive) in a controlling stroke (II-I=mix., I-II=distrib.) under flow \dot{V}_{100}

\dot{V}_{100} = Supply in m³/h

Recommended installation of valves in mixing nodes

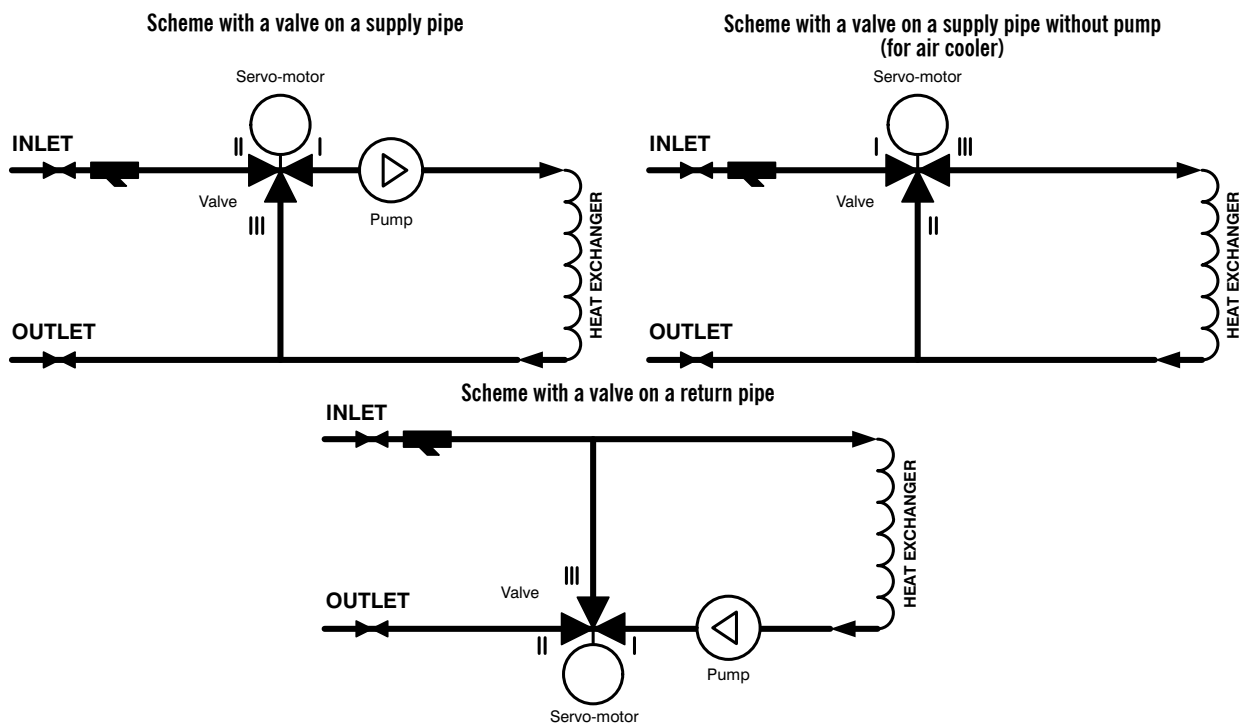

ELECTRIC DRIVES FOR VALVES SSB 61

General information

The drives are meant for control of SIEMENS valves with threaded connection and a rod stroke 5,5 mm (VXP).

Technical data

- Supply voltage: 24 V AC
- Frequency: 50/60 Hz
- Power consumption: 2 VA
- Control signal type: 0-10 V
- Open/close time: 75 sec
- Rod stroke: 5,5 mm
- Nominal force: 200 H
- Protection class: IP40
- Environment temperature: +1... +50° C
- Heat carrier temperature: +1... +110° C
- Weight: 0,4 kg



Dimensions

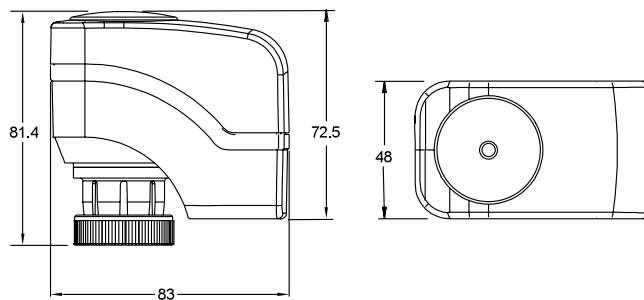

THREE-WAY VALVES 3MG

General information

Three-way valves ESBE 3 MG are used to control water consumption in the heat exchangers. Can be used as mixers or separators for hot or cold water. Consumption level is changed by rotation of the rod. Valves can be mounted in any position.



Technical characteristics

Heat transfer agent temperature	-30... +110° C
Max operational pressure	1 MPa
Max pressure difference on a valve	200 kPa
Ethylene glycol content	Max. 50%
Operational rotation angle	90°
Case material	Brass
Rod material	Brass

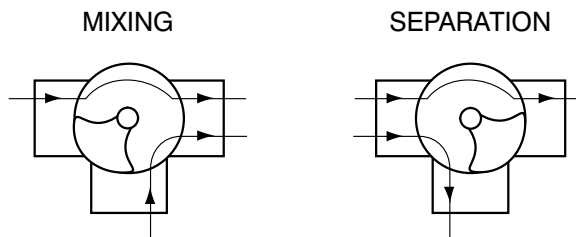

Types

Type	Kvs	Drive	Loss. % from consumption		Dimensions				Weight, kg
			Mixing	Separation	A	B, mm	C, mm	D, mm	
3MG 15-0,6	0,6	ESBE 62P	1,0	0,5	1/2"	35	72	33	0,7
3MG 15-1,0	1,0	ESBE 62P	1,0	0,5	1/2"	35	72	33	0,7
3MG 15-1,6	1,6	ESBE 62P	1,0	0,5	1/2"	35	72	33	0,7
3MG 15-2,5	2,5	ESBE 62P	1,0	0,5	1/2"	35	72	33	0,7
3MG 20-4	4,0	ESBE 62P	1,0	0,5	3/4"	35	72	33	0,6
3MG 20-6,3	6,3	ESBE 62P	1,0	0,4	3/4"	35	72	33	0,6
3MG 25-8,0	8,0	ESBE 62P	1,0	0,3	1"	42	72	33	0,7
3MG 25-12	12	ESBE 62P	1,0	0,3	1"	42	88	37	1,0
3MG 32-18	18	ESBE 62P	1,0	0,3	1 1/4"	50	88	37	1,1

Dimensions

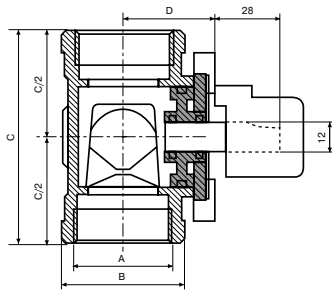

Hydraulic characteristics

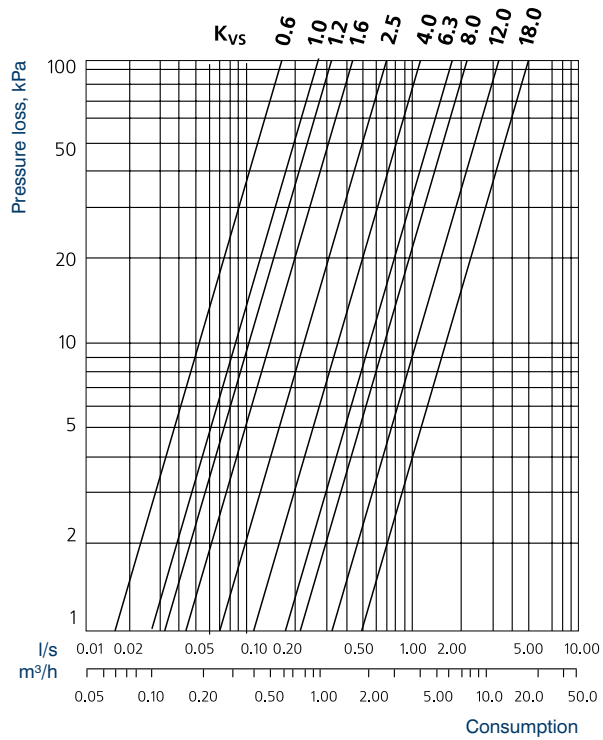

ELECTRIC DRIVES OF ESBE 62P VALVES

General information

Electric drives ESBE 62P are used for analogous control (0-10V) of the three-way rotary valves type 3 MG.



Technical characteristics

Characteristics	Drive type
	ESBE 62P
Power supply voltage	24 V AC
Frequency	50/60 Hz
Control signal	0-10 V or 0-20 mA
Capacity	5 VA
Open/close time	120 s
Return spring	No
Produced force	5H • m
Operation temperature range	-15... +55° C
Protection class	IP 41
Weight	0,4 kg

Dimensions

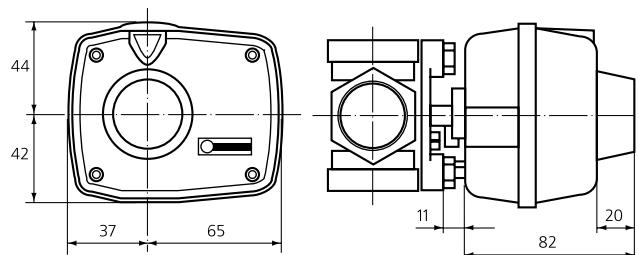

AIR CURTAINS TYPE ZWC

General information

Air curtains class ZWC are of industrial type and used to protect open doorways from a cool outdoor air. Curtains are mounted inside premise at the side or above the doorways.

Curtains are manufactured both without heating (type ZWC H) and with water (type ZWC W) and electric (type ZWC E) air heating.

Curtains are a built-up construction based on rectangular channel elements. Curtains consist of LVP ventilators, two-row water heaters WKN/2, electric heaters EKN, air inlet grid and distributing slot sections. To protect heat exchangers from clogging sets of curtains type ZWC E, ZWC W include cassette filters KFK.

Slotted sections are 1 and 1,5 m long and are made of steel galvanized sheet. All types of curtains are made with the total length of the slotted sections in range from 2 to 5 m with 0,5m pitch.

Curtains are delivered disassembled. All the elements of curtains are fitted with tyre flanges to connect to each other when mounting.



Aizkaru Indication

ZWC 60-35W/2

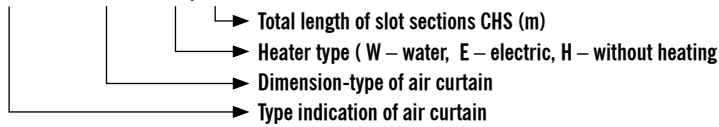

Basic technical characteristics of ZWC air curtains

Dimension-types of air curtains	60-30	60-35	70-40M	70-40	80-50
Max. air consumption (m ³ /h)	3075	4170	4520	6280	7080
Electric power supply	3x380V	3x380V	3x380V	3x380V	3x380V
Ventilator drive nominal capacity (kW)	1,1	1,5	1,5	3	3
Ventilator nominal current (A)	2,5	3,45	3,45	5,9	5,9
Ventilators used	LVP 60-30/28.2D	LVP 60-35/31.2D	LVP 70-40/31.2DM	LVP 70-40/35.2D	LVP 80-50/35.2D
Water heaters used	WKN 60-30/2	WKN 60-35/2	WKN 70-40/2	WKN 70-40/2	WKN 80-50/2
Electric heaters used	EKN 60-30/15	EKN 60-35/22.5	EKN 70-40/30	EKN 70-40/30	EKN 80-50/30
EKN heater current (A)	22.6	33.9	45.1	45.1	45.1
Capacity of electric heater (kW)	15	22.5	30	30	30
Filters and filter inserts used	KFK 60-30 WFK 60-30 (G3)	KFK 60-35 WFK 60-35 (G3)	KFK 70-40 WFK 70-40 (G3)	KFK 70-40 WFK 70-40 (G3)	KFK 80-50 WFK 80-50 (G3)

Selection method

Air curtains selection in result gives the dimension-type of an air curtain needed for specific operation conditions and specific doorways.

Curtain orientation		Operation range	Slot length
One-side installation	Side	Doorway width (m)	Doorway height (m)
One-side installation	Above	Doorway height (m)	Doorway width (m)
Two-sides installation	Side	½ doorway width (m)	Doorway height (m)
Two-sides installation	Above	Doorway height (m)	½ doorway width (m)

Selection order

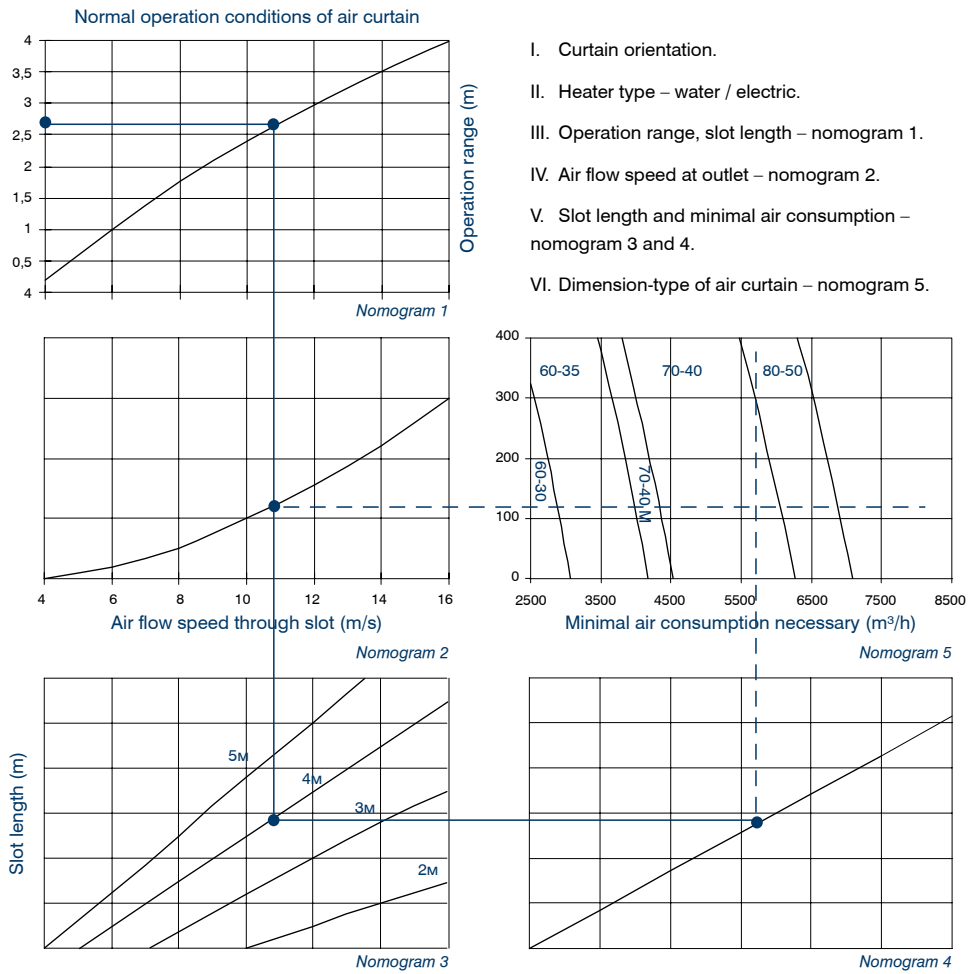

Basic dimensions of ZWC air curtains

Curtain dimension-types	60-30	60-35	70-40M	70-40	80-50
A, m.	0,6	0,6	0,7	0,7	0,8
B, m.	0,3	0,35	0,4	0,4	0,5
I1, m	From 2,0 to 5,0				
I2 (without heating), m.	0,72	0,75	0,85	0,85	0,97
I2 (with water heating), m	1,12	1,15	1,25	1,25	1,38
I2 (with electric heating), m	1,3	1,38	1,53	1,53	1,76

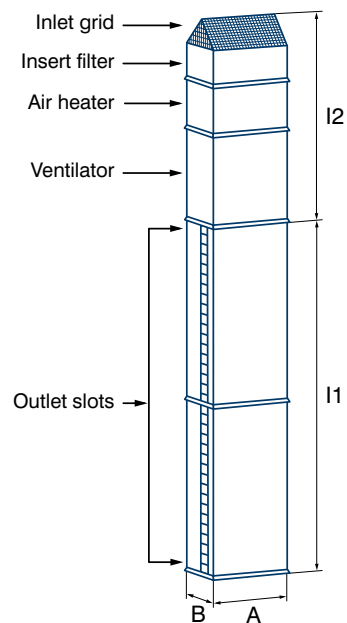

AIR CURTAINS CONTROL UNITS PU-ZWC...

General information

Control units of curtains type PU-ZWC... are used for work with air curtains ZWC.
 The following control units modifications are manufactured:
 PU-ZWC-W for curtains with water heaters,
 PU-ZWC-E for curtains with electric radiators.



Unit types

Name	Ventilator capacity, kW	Electric heater capacity, kW	Curtains used
PU-ZWC-W-1,5	1,1 - 1,5	-	ZWC 60-30 W, ZWC 60-35 W, ZWC 70-40M W
PU-ZWC-W-3	3	-	ZWC 70-40 W, ZWC 80-50 W
PU-ZWC-E15-1,1	1,1	15	ZWC 60-30 E
PU-ZWC-E30-1,5	1,5	22,5 - 30	ZWC 60-35 E, ZWC 70-40M E
PU-ZWC-E30-3	3	30	ZWC 70-40 E, ZWC 80-50 E

Operation conditions

Control units PU-ZWC... can be used in dry, clean premises without dust and chemical particles. Allowable temperature of the environment – +5° to +40° C.

Construction

Boxes have plastic case with transparent lid. Box dimensions are 275×365×140.

The unit protection level is IP 65 with closed lid and IP 40 with open lid.

The power part of the unit consists of the knife-switches, protective automatic units, magnetic starters and clamps.

Control and protection functions are provided with the relay logic circuits.

Standard functions

Control units PU-ZWC are used to start-up, shutdown and protection of connected air curtains. The units have the following functions:

- manual start and shutdown;
- external start and shutdown by any contact device;
- control and protection of ventilator without thermocontacts;
- control and protection of heating water pump (PU-ZWC-W type);
- control and protection of the electric radiator (PU-ZWC-E type);
- adjusted delay of ventilator shutdown (PU-ZWC-E type).

Control units PU-ZWC-W do not provide the protection of water heat exchangers from freezing, so the exploitation of such curtains is possible only in premises with positive temperatures.

With no water circulating in the heat-provision system the pump must be shut down to avoid its damage.

Cesu street 31, building 1, 3d floor, Riga, Latvia, LV-1012

Tel: 7501707, 7501708; Fax: 7501710

e-mail: info@evr.lv

www.evr.lv

Manufacturer can make alterations
without prior notice.